

Parts Catalogue

'17-'18 ZR1000 HHF/HJF(EU)
(Z1000)

'17-'18 ZR1000 HHF/HJF

Model Information

Year & Model	'17 ZR1000HHF	'18 ZR1000HJF
Color	1.CANDY BURNT ORANGE(17L) 2.METALLIC SPARK BLACK(660)	1.PEARL STORM GRAY(36S) 2.EMERALD BLAZED GREEN(60R)
VIN No. Range	JKAZRT00HHA000001 - 005000	JKAZRT00HHA005001 -
Engine No. Range	ZRT00DE000001 -	ZRT00DE000001 -
Owner's Manual No.	99976-0033(E/F/G) 99976-0034(I/ES/NL)	99976-0086(E/F/G) 99976-0087(I/ES/NL)
Service Manual No.	99924-1518-01	99924-1518-03

PARTS LIST INFORMATION

This parts catalog lists parts and sub-assemblies provided as spare parts. When it becomes necessary to replace parts always use KAWASAKI GENUINE PARTS. Strict inspection assures quality and performance of KAWASAKI GENUINE PARTS.

1. HOW TO PLACE AN ORDER FOR PART

When ordering parts be sure to use the catalog for the correct model and year of the vehicle. Include the following items exactly as listed in this catalog on your parts order.

- Part Number
Part Name
Color Code
Specify the color using both color code (which is part of the part number) and name when ordering painted parts.
Example: 51001-5074-H8 TANK-COMP-FUEL,EBONY

Parts not shown disassembled in the illustrations of this parts catalog are not sold separately; only the complete units or next higher assemblies illustrated, are supplied, as spare parts.

2. EXPLANATION OF PARTS CATALOG FORMAT

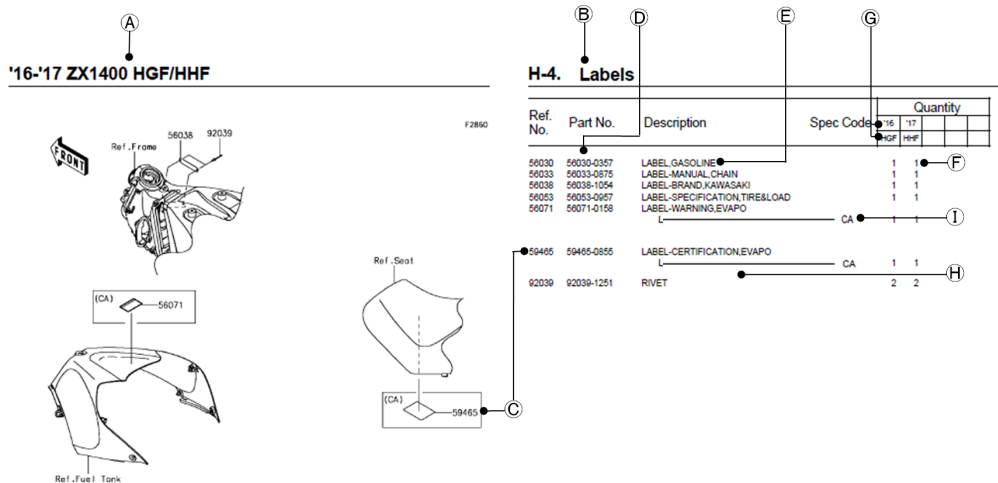

A. Year & Model Title

This title describes the year(s) and model(s) contained in this catalog.

B. Part Group Title

A representative name for the group of parts illustrated on this page.

C. Reference Number

The reference number is listed on the illustration and parts list. It is the link between the illustration and the parts list.

D. Part Number

The number assigned to a part for the purpose of parts ordering.

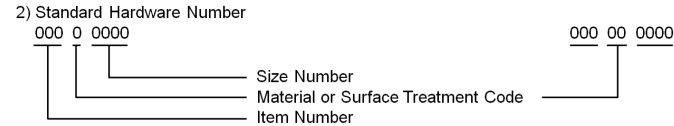
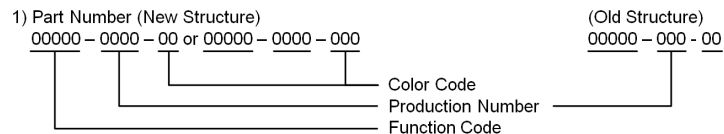

E. Description

Describes the main function of the part and includes data such as size, number of teeth, color, etc.

List of Abbreviations

Table listing abbreviations and their meanings: (+) Plus, (-) Minus, & And, 2ND Second, 3RD Third, 4TH Fourth, AR As Required, ASSY Assembly, CA Cut Away, CNT Center, COMP Complete, D Degree, FR Front, G Gram, HEX Hexagonal, ID Inside Diameter, KPH Kilometers Per Hour, L Link, L= Length, L/ Less, LH Left Hand, LWR Lower, MM Millimeter, MPH Miles Per Hour, NA Not Available, O/S Over Size, OD Outside Diameter, PR Ply Rating, REF Reference, RH Right Hand, RPM Revolutions Per Minute, RR Rear, STD Standard, T Teeth, T= Thickness, U/S Under Size, UPP Upper, V Volt, W Watt, W/ With, WD With Decal, WOD Without Decal

F. Quantity

Specifies how many of a part are required at the indicated position on the illustration.

G. Year & Model

Indicates which parts are used for a specific vehicle year and model.

H. Additional Information

Additional Information is shown as follows:

- 1) (OPTION) Part is not installed as original equipment, but is available separately.
2) (RACING USE ONLY) Part is to be used for closed course racing only on this vehicle.
3) (OFF-ROAD USE ONLY) Part is for off-road use only this vehicle.
4) (LOCAL PROCUREMENT ITEM) Part is obtainable from a local source. No part number is listed.
5) Technical relationships between old part numbers and new part numbers are shown as follows: INTERCHANGE - Old part or new part can be used. UBSSTITUTE - New part replaces old part. Old part cannot be used in place of new part.
6) Mid-Year part number changes on a vehicle are noted by engine or frame number references.

(- KZ400DE001181) Affected units are from beginning of model year production up to and including this engine number.
(KZ400D-008111 -) Affected units are from this frame number to the end of model year production.
(KZ400DE008181 - KZ400DE018888) Affected units are in this engine number range.

I. Specification Code

Identifies the specification of the vehicle for which the part applies. If no spec code is listed, that means the part is used for all specifications.

Table with columns: Spec Code, Specification, '17 HHF, '18 HJF, and empty columns. Row 1: WV, Whole Vehicle Type Approval, O, O.

ZR1000HHF

Left Side View

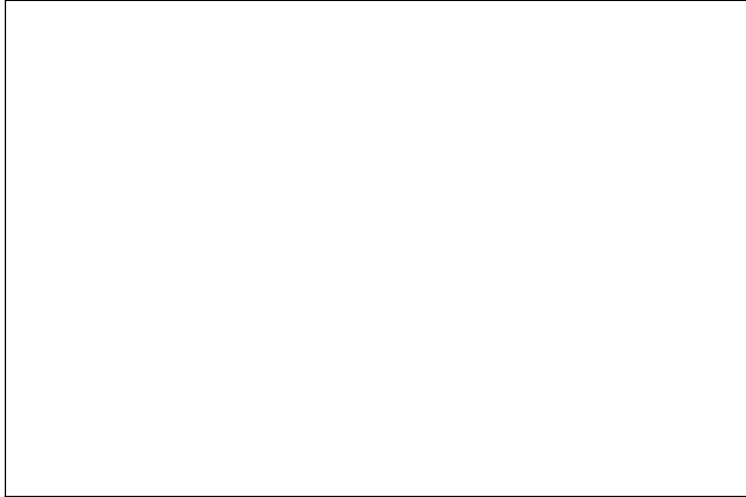

Right Side View

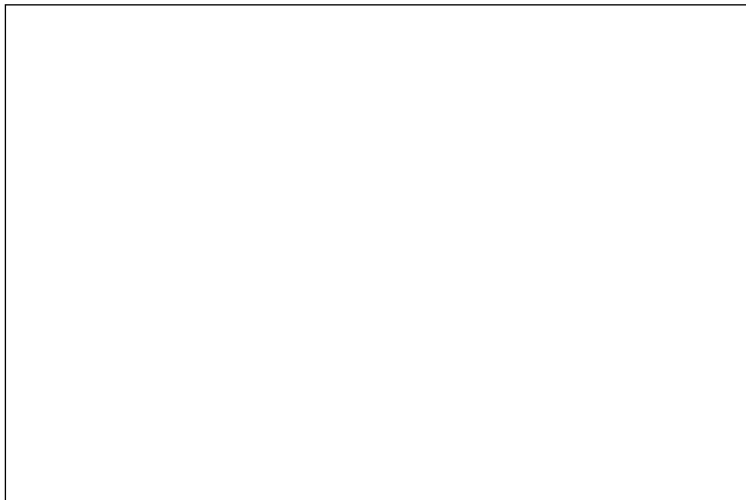

ZR1000HJF

Left Side View

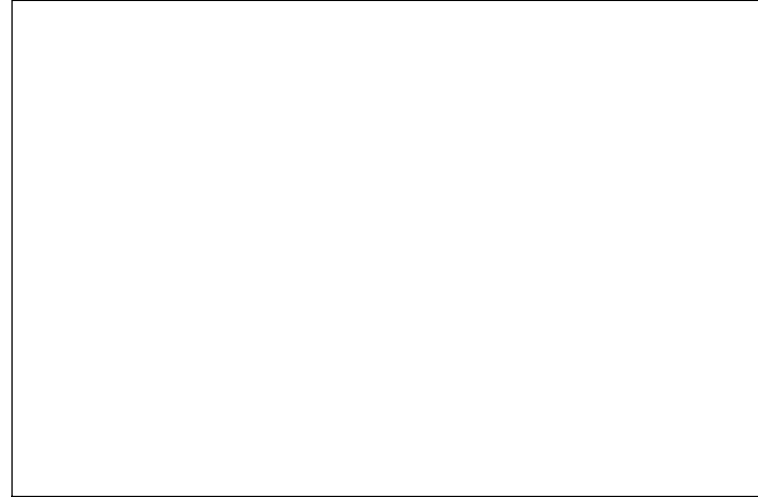

Right Side View

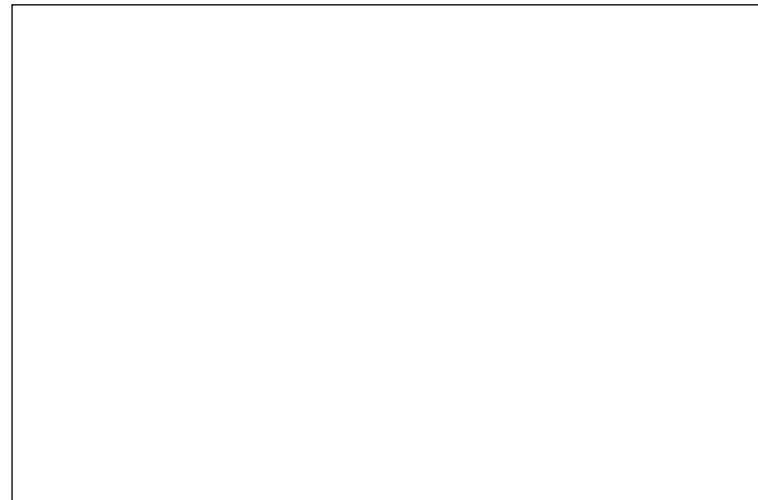

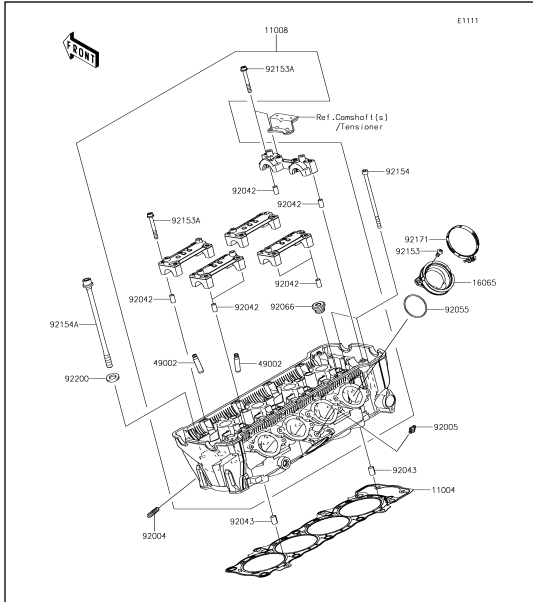

E1111

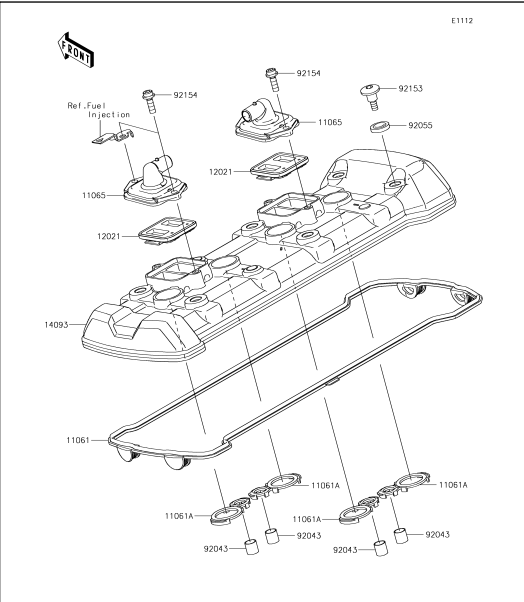

E1112

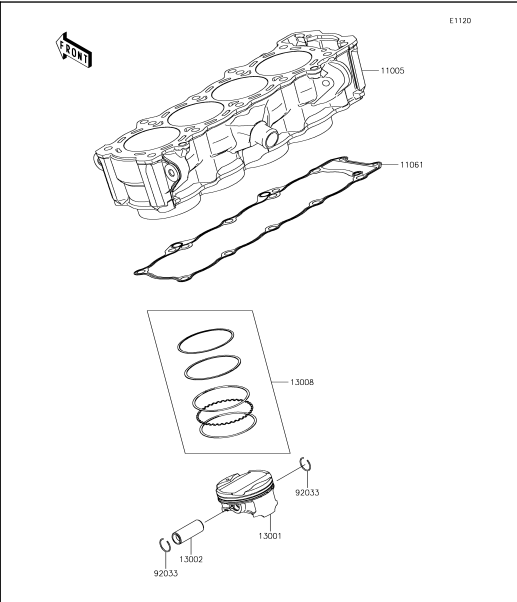

E1120

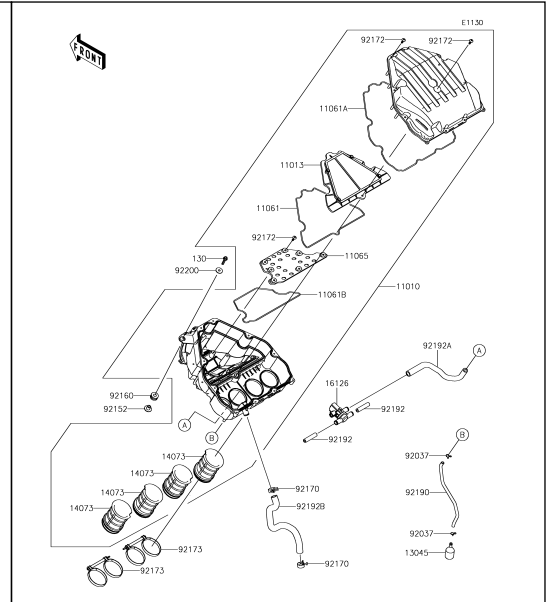

E1130

1 Cylinder Head

2 Cylinder Head Cover

3 Cylinder/Piston(s)

4 Air Cleaner

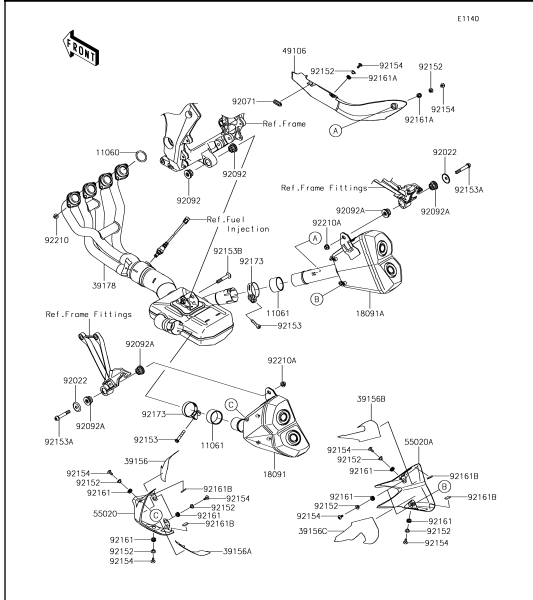

E1140

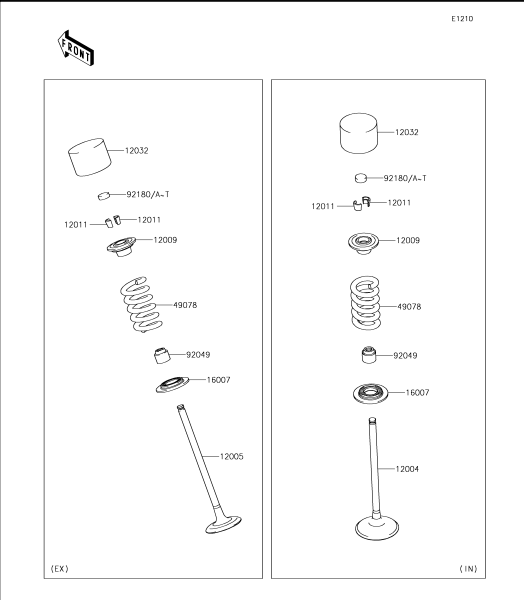

E1210

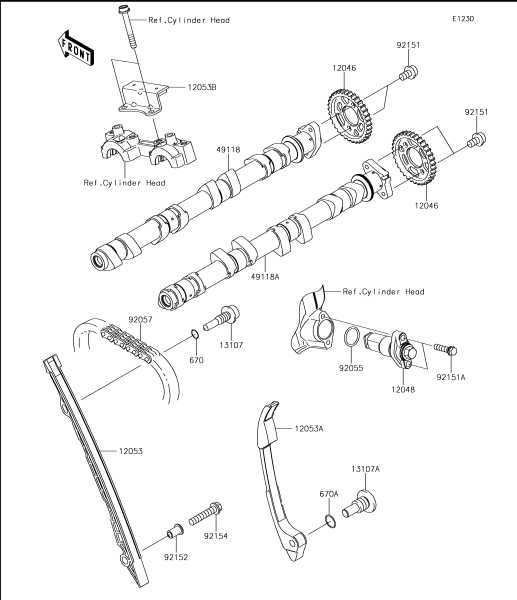

E1230

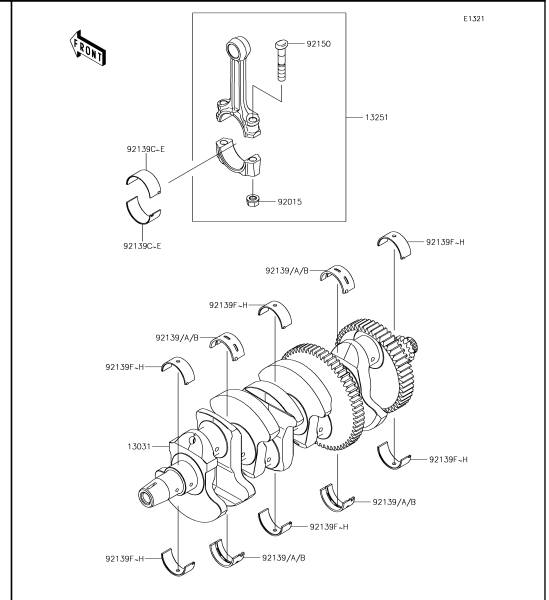

E1321

5 Muffler(s)

6 Valve(s)

7 Camshaft(s)/Tensioner

8 Crankshaft

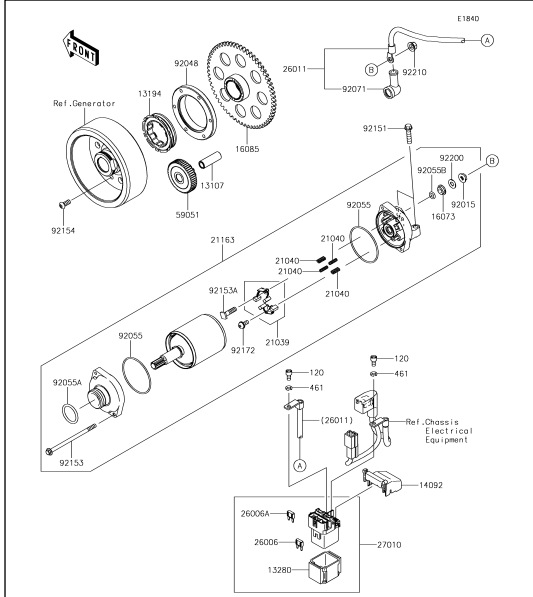

25 Starter Motor

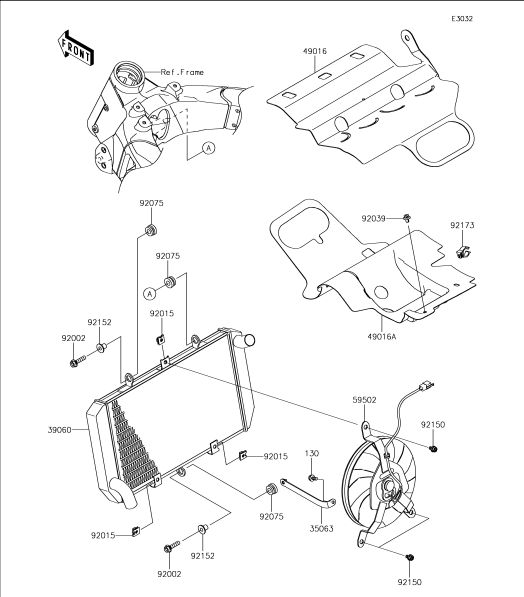

26 Radiator

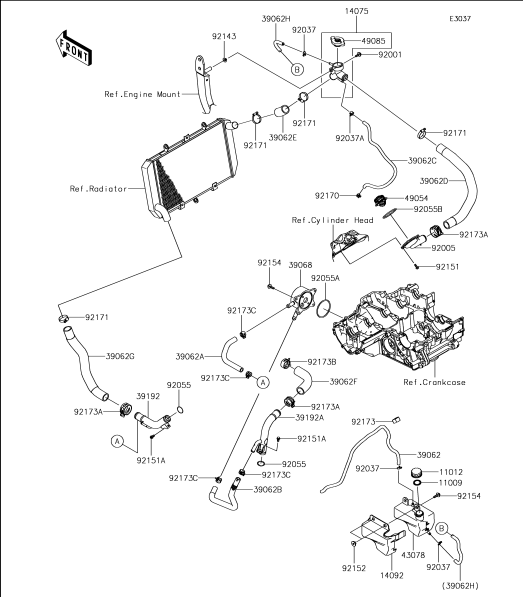

27 Water Pipe

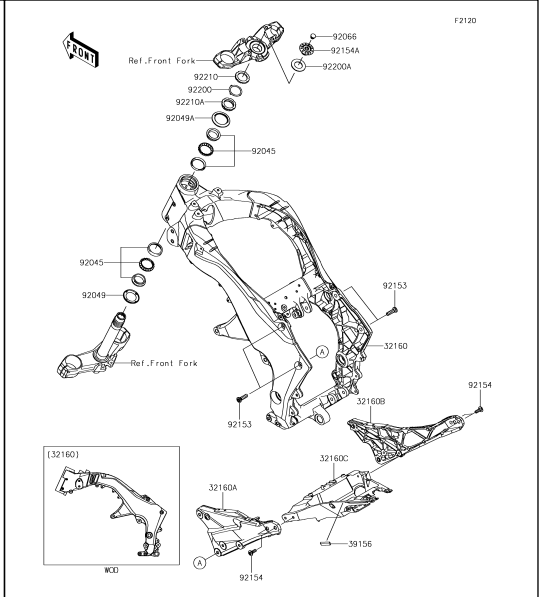

28 Frame

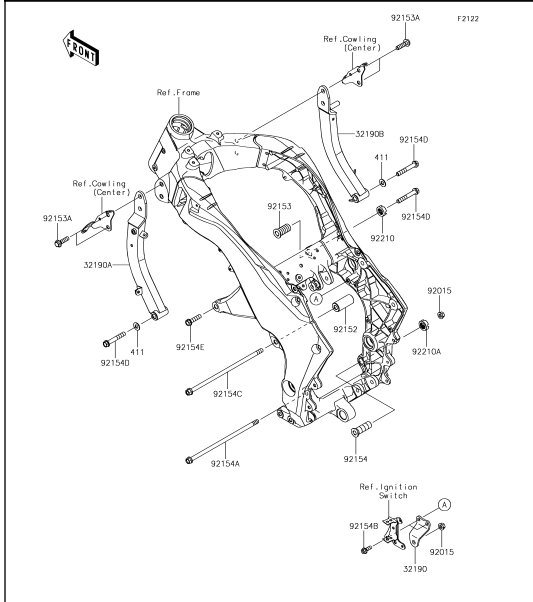

29 Engine Mount

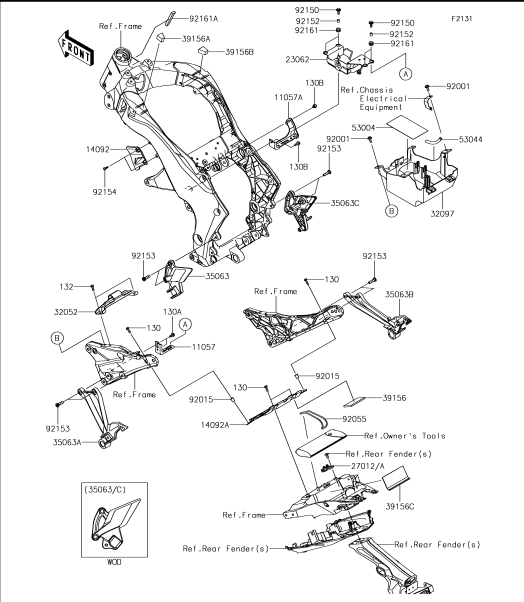

30 Frame Fittings

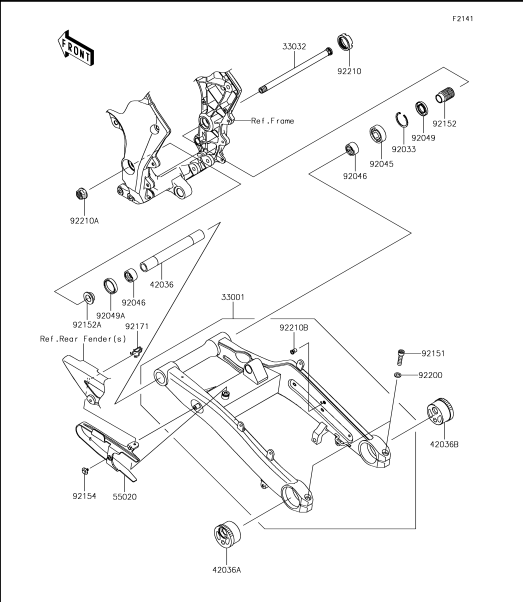

31 Swingarm

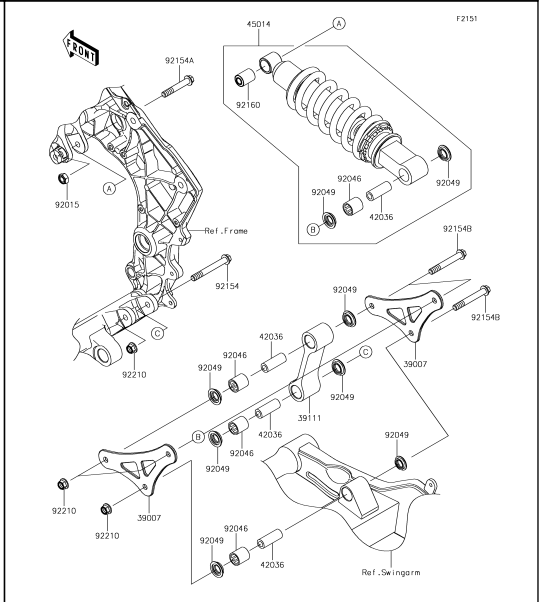

32 Suspension/Shock Absorber

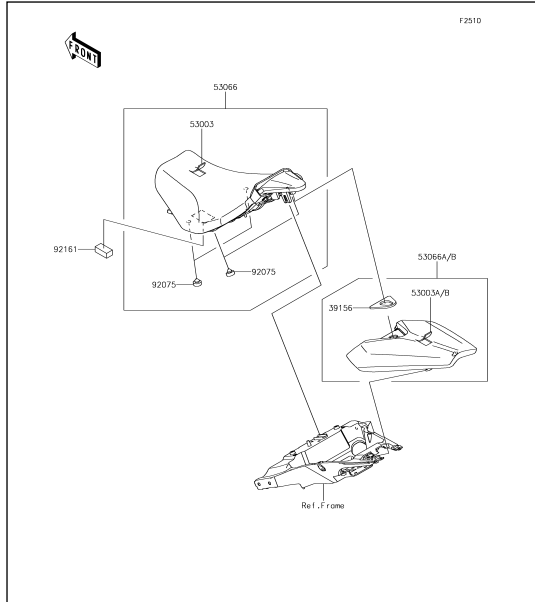

49 Seat

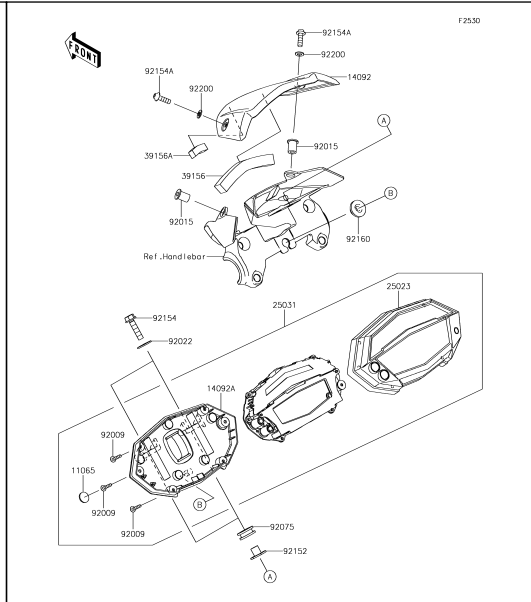

50 Meter(s)

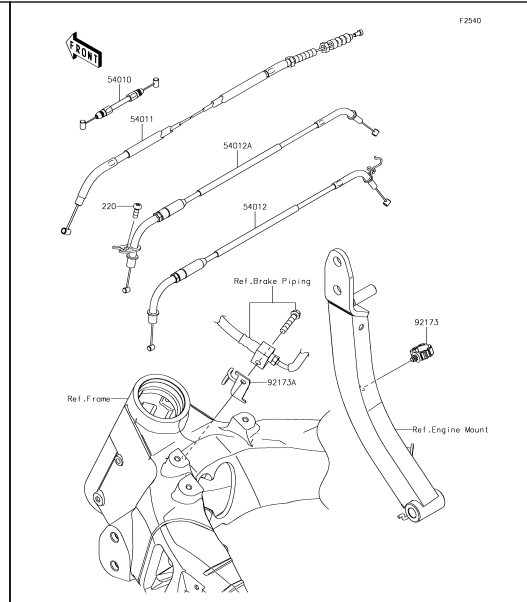

51 Cables

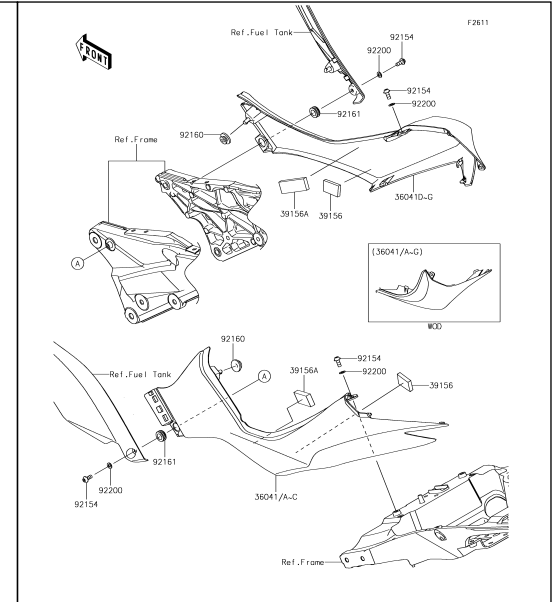

52 Side Covers

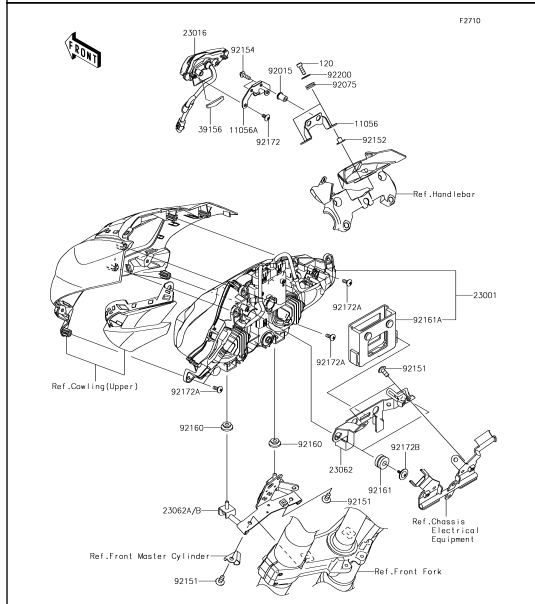

53 Headlight(s)

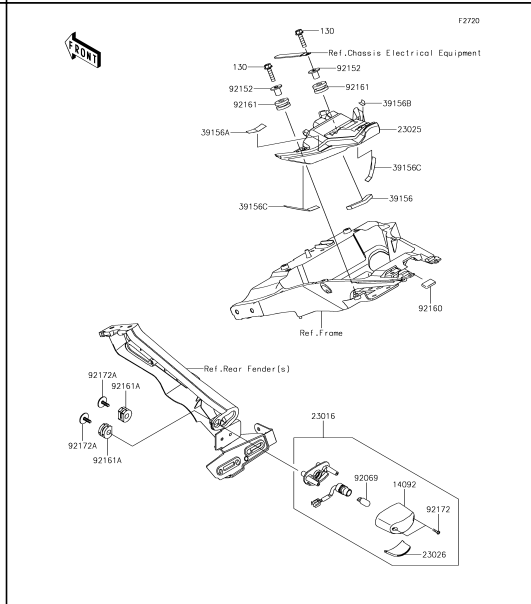

54 Taillight(s)

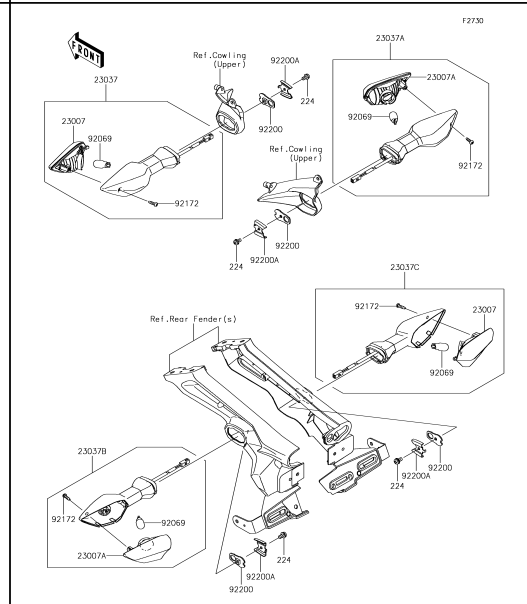

55 Turn Signals(HHF)

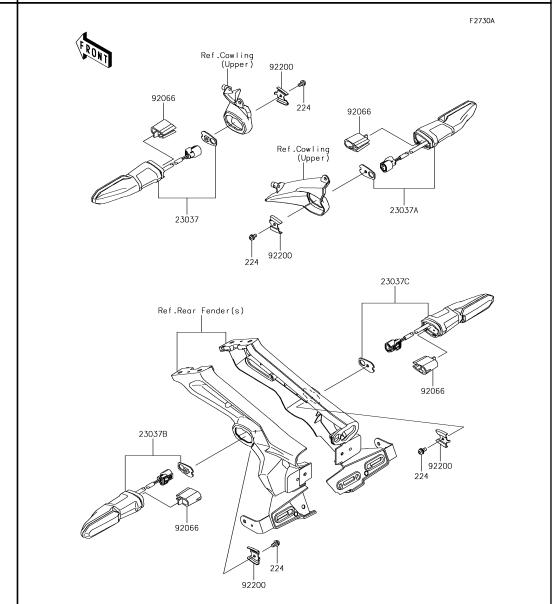

56 Turn Signals(HJF)

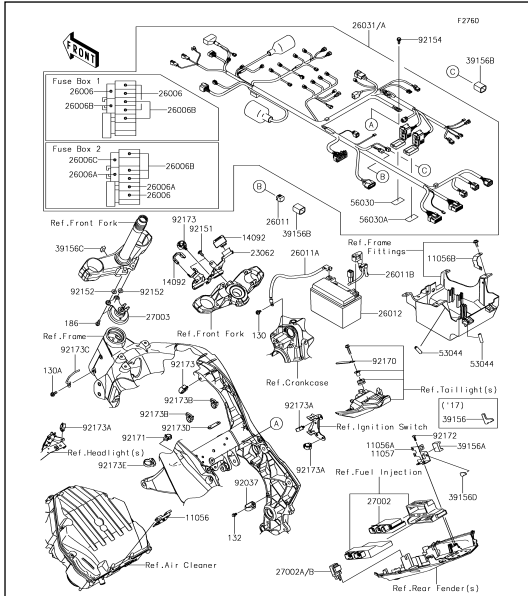

57 Chassis Electrical Equipment

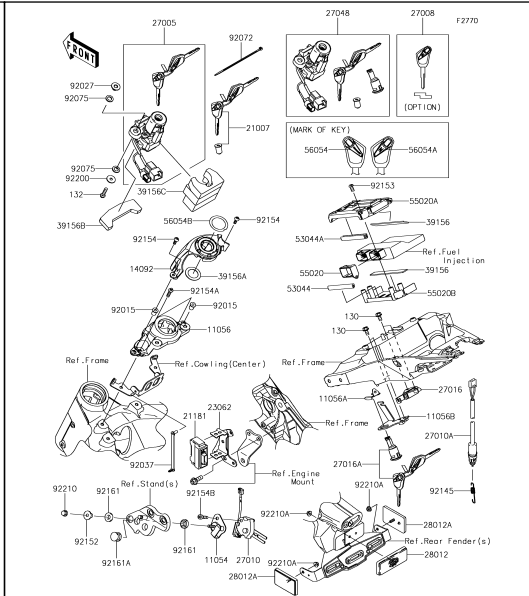

58 Ignition Switch

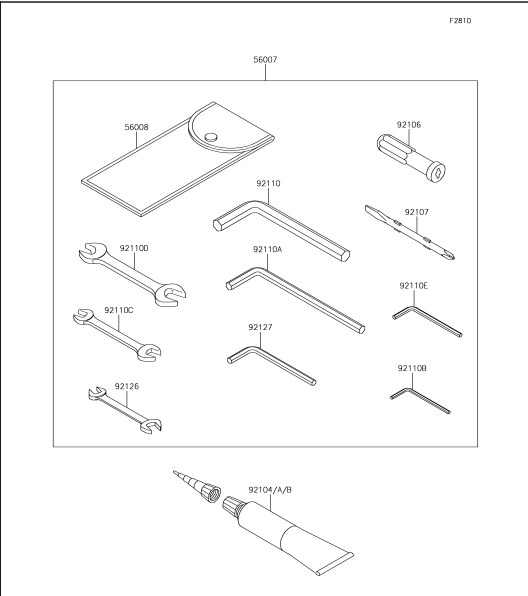

59 Owner's Tools

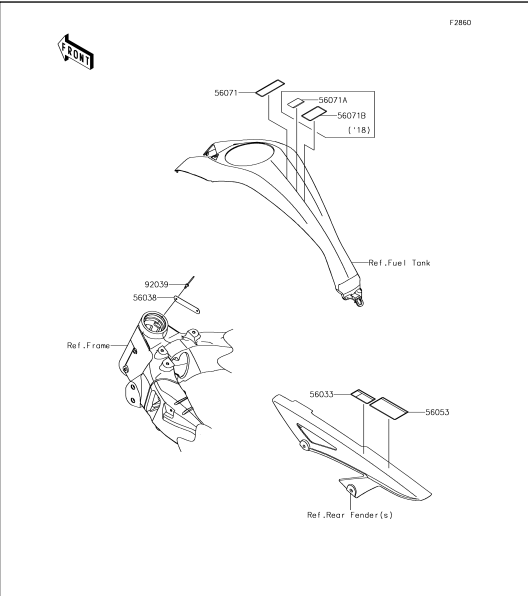

60 Labels

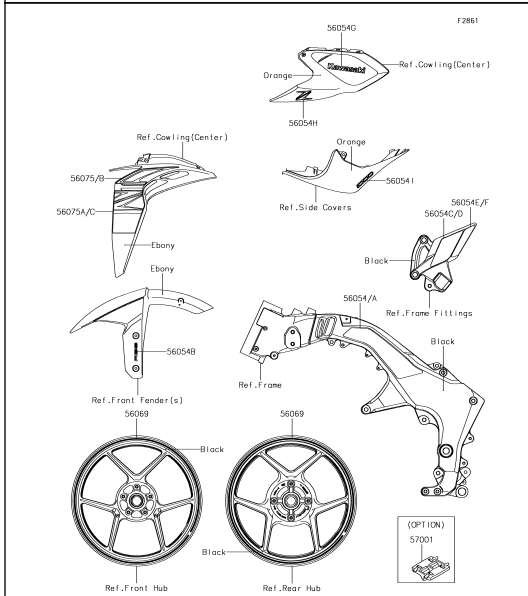

61 Decals(Orange)(HHF)

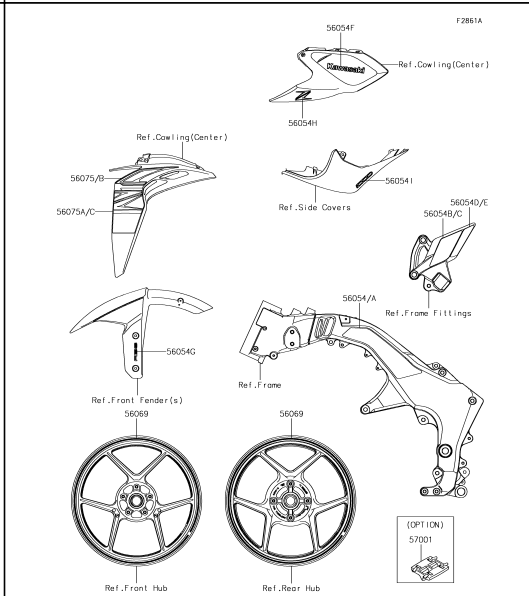

62 Decals(Black)(HHF)

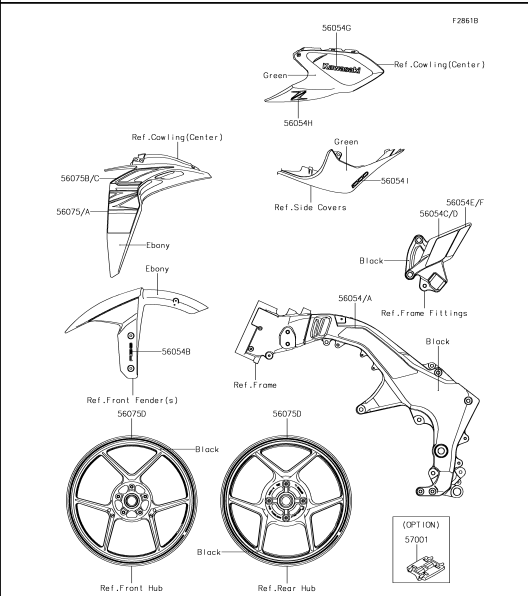

63 Decals(Green)(HJF)

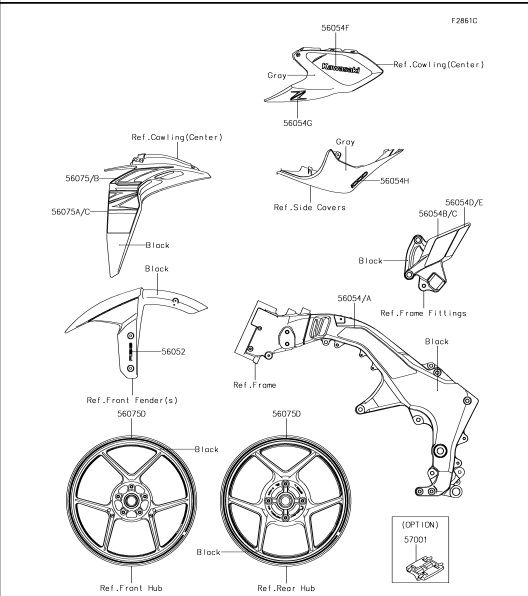

64 Decals(Gray)(HJF)

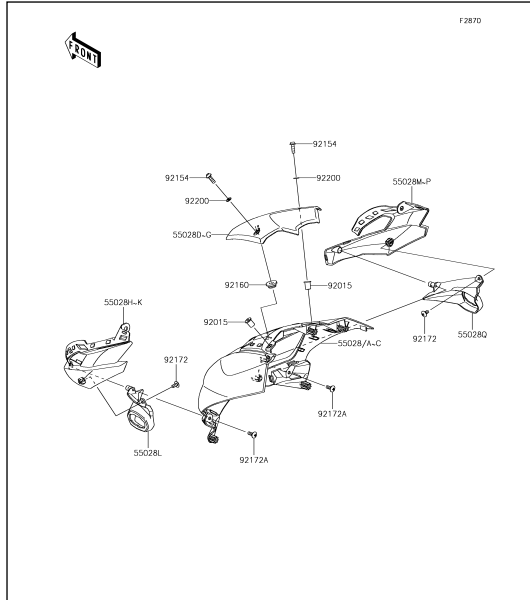

65 Cowling(Upper)

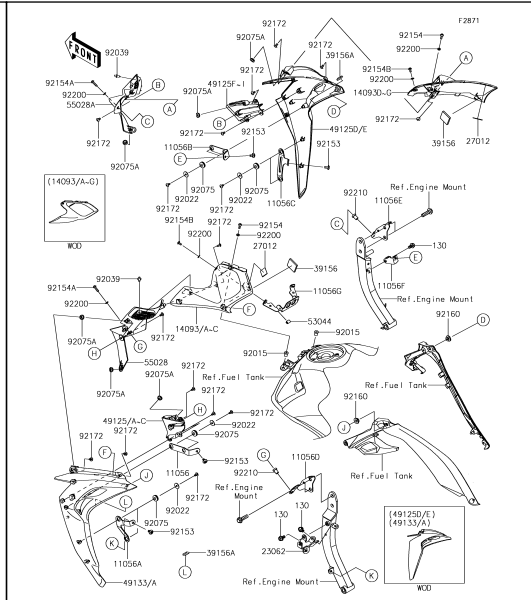

66 Cowling(Center)

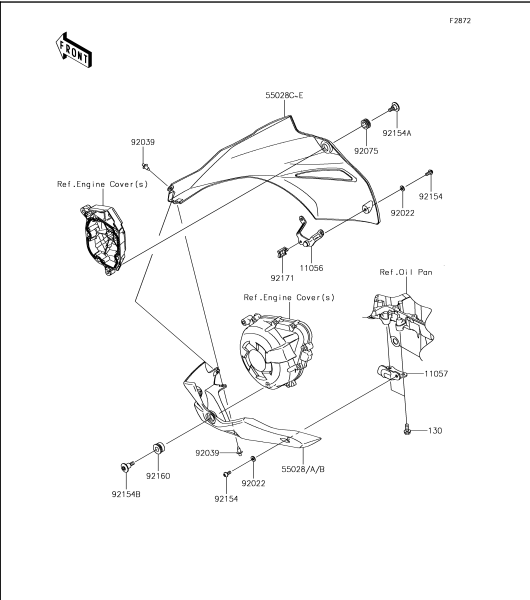

67 Cowling(Lowers)

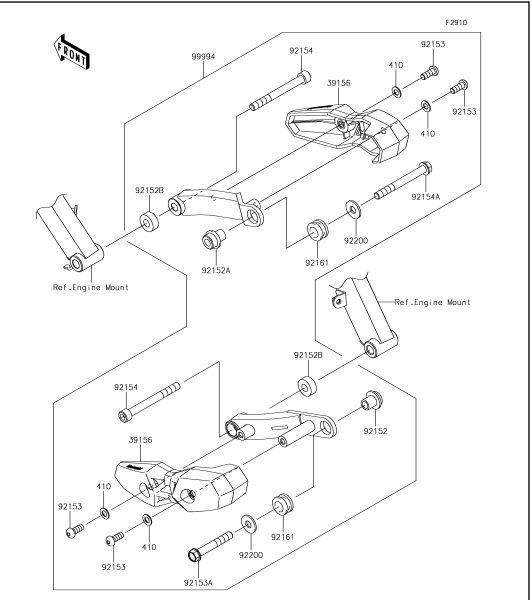

68 Accessory(Shroud Slider)

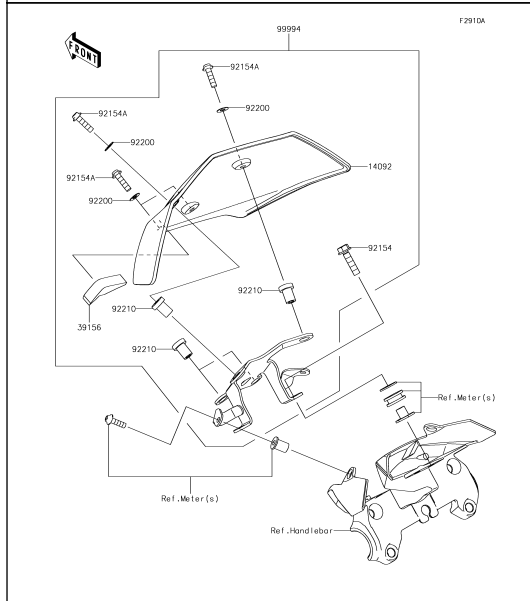

69 Accessory(Meter Cover)

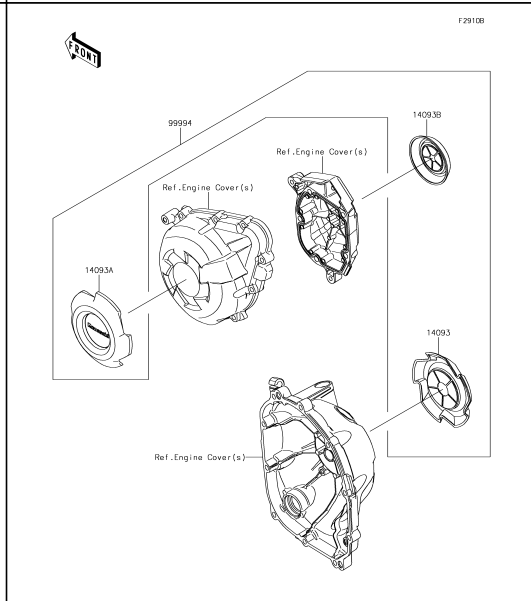

70 Accessory(Crankcase Ring)

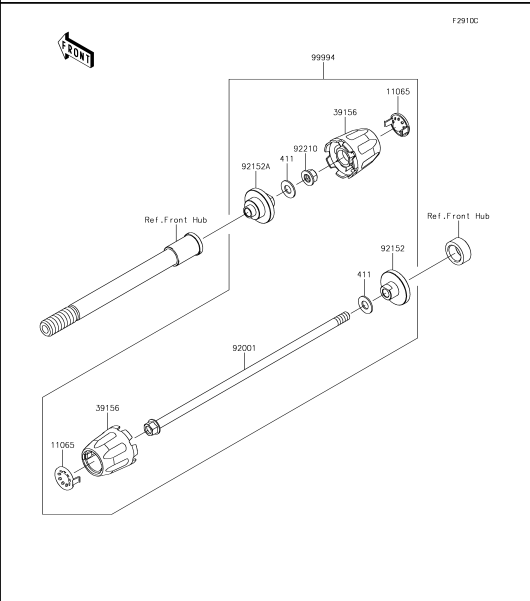

71 Accessory(Axle Slider)

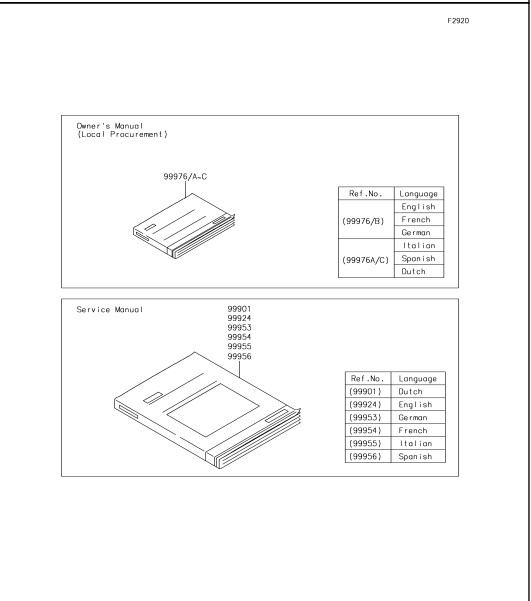

72 Manual

E1111

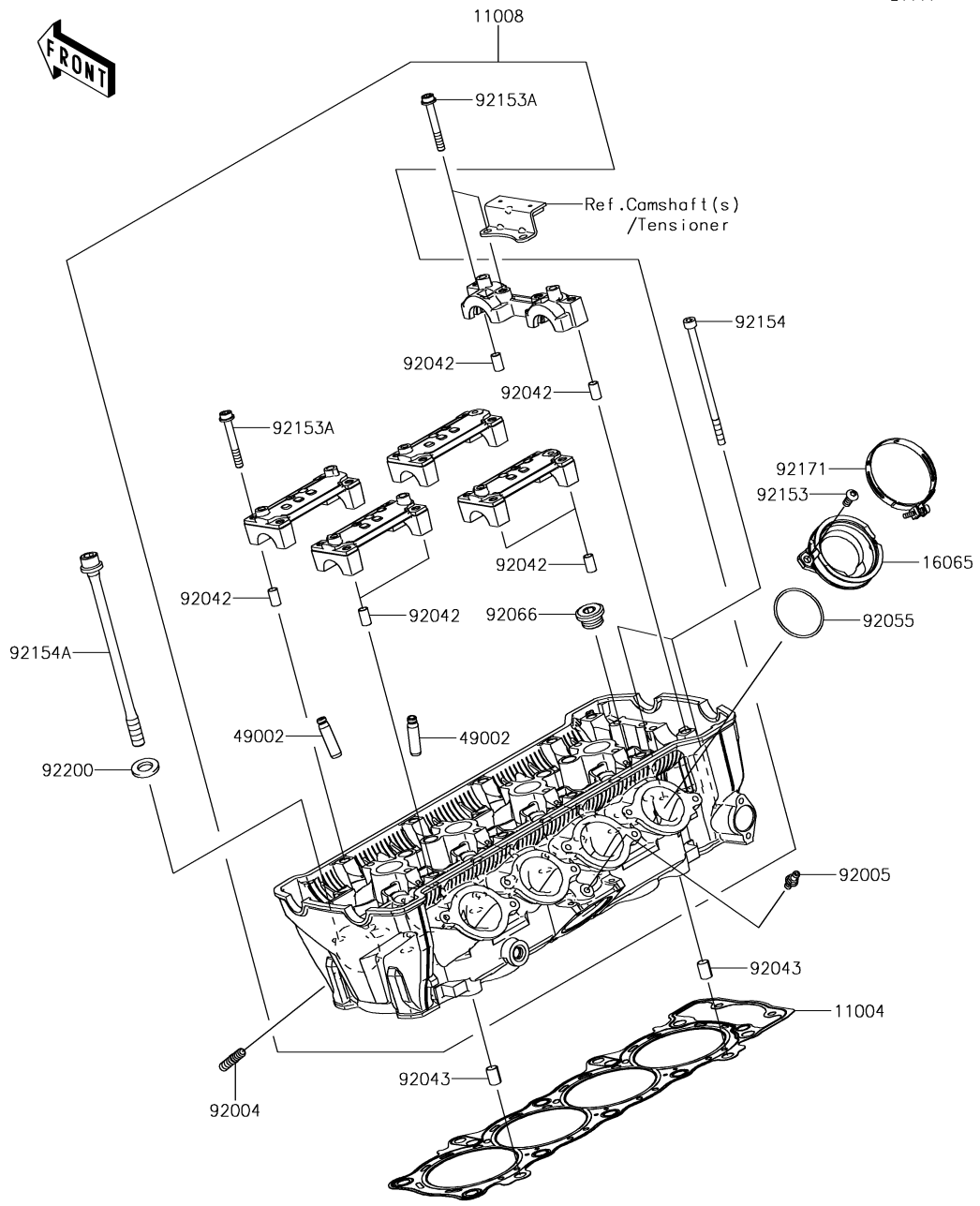

1. Cylinder Head

Ref. No.	Part No.	Description	Spec Code	Quantity			
				'17	'18		
				HHF	HJF		
11004	11004-0084	GASKET-HEAD		1	1		
11008	11008-0897	HEAD-COMP-CYLINDER		1	1		
16065	16065-0067	HOLDER-CARBURETOR		4	4		
49002	49002-0009	GUIDE-VALVE		16	16		
92004	92004-0050	STUD		8	8		
92005	92005-1273	FITTING		1	1		
92042	92042-007	PIN,DOWEL,6.3X8X14		10	10		
92043	92043-1264	PIN,8.2X10X14		2	2		
92055	92055-1536	RING-O,42X1.9		4	4		
92066	92066-0832	PLUG,18X10		5	5		
92153	92153-0406	BOLT,TORX,6X14		8	8		
92153A	92153-0656	BOLT,SOCKET,6X45		20	20		
92154	92154-0205	BOLT,SOCKET,6X115		2	2		
92154A	92154-2638	BOLT,FLANGED,10X165		10	10		
92171	92171-0729	CLAMP,60MM		4	4		
92200	92200-1691	WASHER,10.2X18.4X1.8		10	10		

E1112

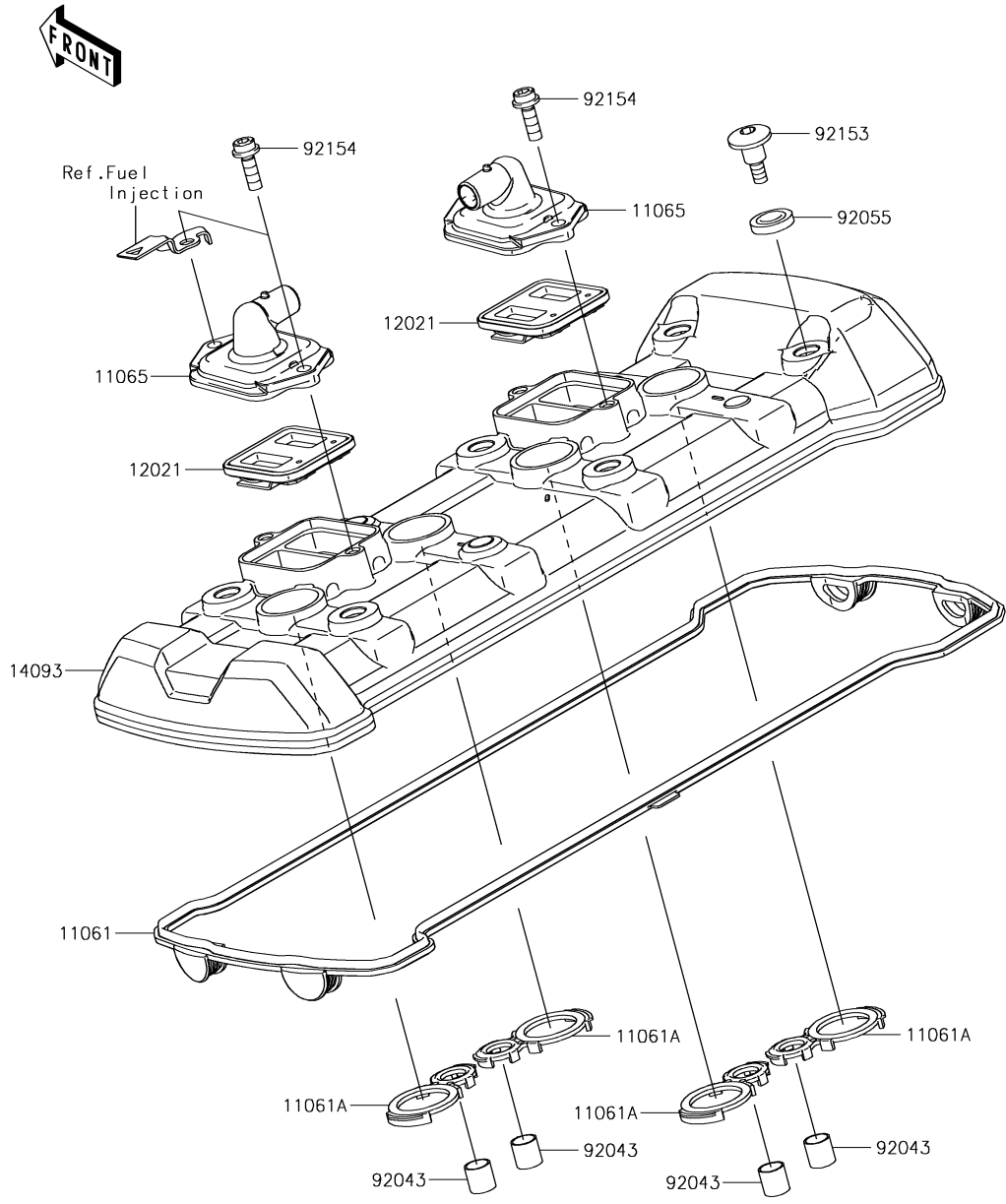

2. Cylinder Head Cover

Ref. No.	Part No.	Description	Spec Code	Quantity			
				'17	'18		
				HHF	HJF		
11061	11061-0914	GASKET,HEAD		1	1		
11061A	11061-1213	GASKET,SPARK PLUG		4	4		
11065	11065-0328	CAP,HEAD COVER		2	2		
12021	12021-0016	VALVE-ASSY-REED		2	2		
14093	14093-0562	COVER,HEAD		1	1		
92043	92043-4009	PIN,10.1X12X14		4	4		
92055	92055-0785	RING-O		6	6		
92153	92153-1779	BOLT,SOCKET,6X22.5		6	6		
92154	92154-0351	BOLT,SOCKET,6X18		4	4		

3. Cylinder/Piston(s)



E1120

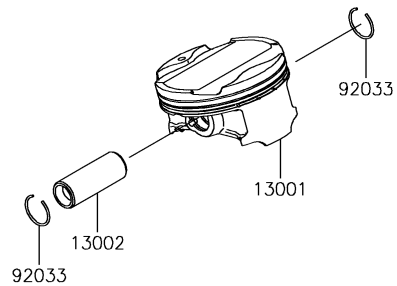
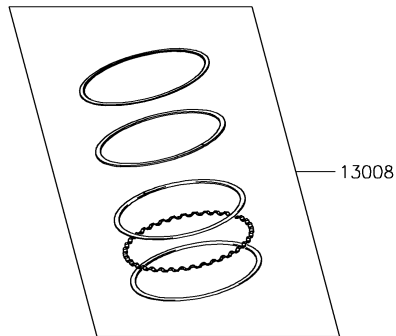
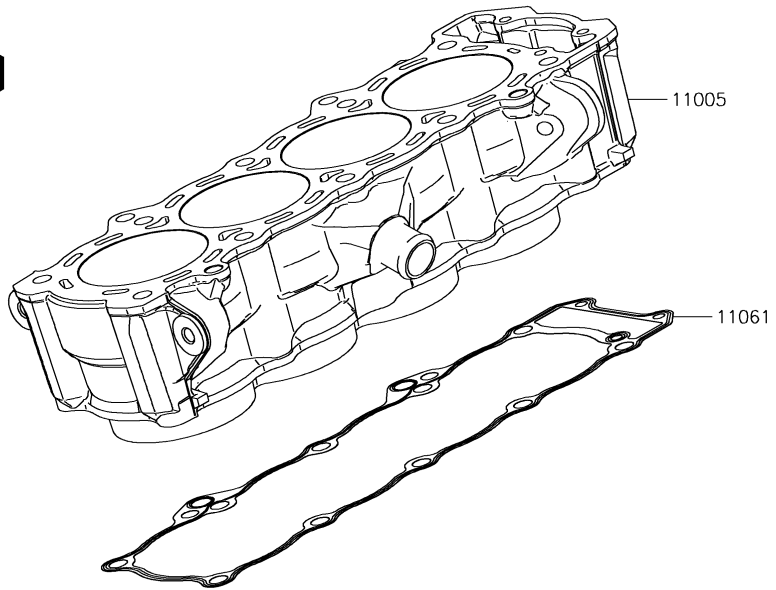

Ref. No.	Part No.	Description	Spec Code	Quantity			
				'17	'18		
				HHF	HJF		
11005	11005-0627	CYLINDER-ENGINE		1	1		
11061	11061-0402	GASKET,CYLINDER BASE		1	1		
13001	13001-0114	PISTON-ENGINE		4	4		
13002	13002-0004	PIN-PISTON		4	4		
13008	13008-0572	RING-SET-PISTON		4	4		
92033	92033-1054	RING-SNAP		8	8		

4. Air Cleaner

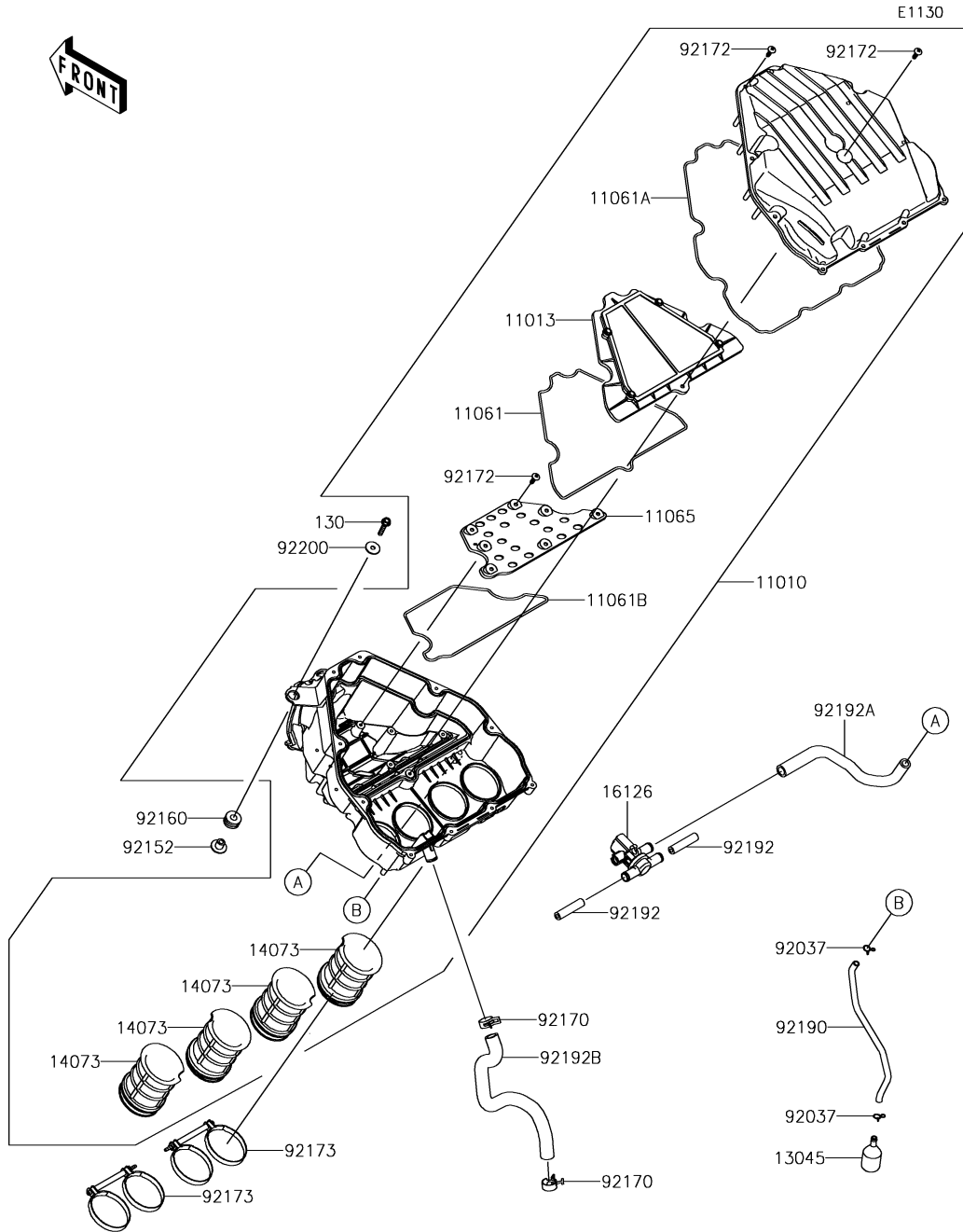

Ref. No.	Part No.	Description	Spec Code	Quantity			
				'17	'18		
				HHF	HJF		
11010	11010-0857	FILTER-ASSY-AIR		1	1		
11013	11013-0712	ELEMENT-AIR FILTER		1	1		
11061	11061-0405	GASKET,ELEMENT		1	1		
11061A	11061-0406	GASKET,CASE		1	1		
11061B	11061-0424	GASKET		1	1		
11065	11065-0815	CAP		1	1		
13045	13045-1057	RECEIVER-OIL		1	1		
14073	14073-0722	DUCT,INTAKE FUNNEL		4	4		
16126	16126-0038	VALVE,AIR SWITCHING		1	1		
92037	92037-1712	CLAMP		2	2		
92152	92152-0547	COLLAR,6.5X10.5X13.1		1	1		
92160	92160-1162	DAMPER		1	1		
92170	92170-1060	CLAMP		2	2		
92172	92172-0483	SCREW,TAPPING,5X20		18	18		
92173	92173-0115	CLAMP		2	2		
92190	92190-1253	TUBE,6X9X300		1	1		
92192	92192-0843	TUBE,HEAD-ASWV		2	2		
92192A	92192-0844	TUBE,ASV-A/C		1	1		
92192B	92192-0845	TUBE,BLOWBY		1	1		
92200	92200-1087	WASHER,6.5X22X1.6		1	1		
130	130BB0630	BOLT-FLANGED,6X30		1	1		

E1140

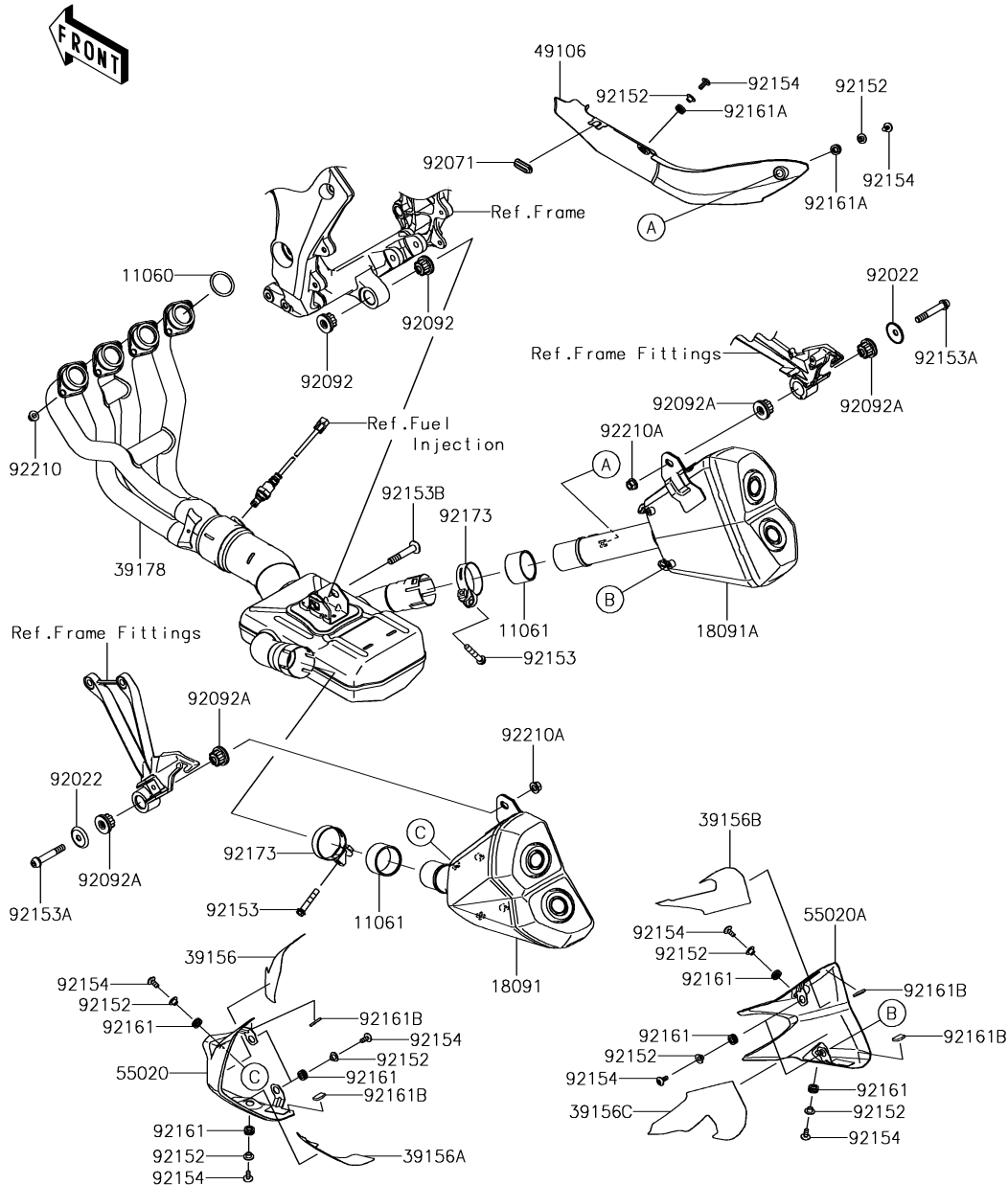

5. Muffler(s)

Ref. No.	Part No.	Description	Spec Code	Quantity			
				'17	'18		
				HHF	HJF		
11060	11060-1103	GASKET,EXHAUST PIPE HOLDER	4	4			
11061	11061-0726	GASKET,MUFFLER CONNECTING	2	2			
18091	18091-1108	BODY-COMP-MUFFLER,LH	1	1			
18091A	18091-1120	BODY-COMP-MUFFLER,RH	1	1			
39156	39156-1728	PAD,LH,UPP	1	1			
39156A	39156-1729	PAD,LH,LOW	1	1			
39156B	39156-1730	PAD,RH,UPP	1	1			
39156C	39156-1731	PAD,RH,LOW	1	1			
39178	39178-0266	MANIFOLD-COMP-EXHAUST	1	1			
49106	49106-0762	COVER-MUFFLER	1	1			
55020	55020-0907	GUARD,LH	1	1			
55020A	55020-0908	GUARD,RH	1	1			
92022	92022-289	WASHER	2	2			
92071	92071-0722	GROMMET	1	1			
92092	92092-1081	BUSHING-RUBBER	2	2			
92092A	92092-1087	BUSHING-RUBBER,MUFFLER	4	4			
92152	92152-0286	COLLAR,6.3X8.3X16	10	10			
92153	92153-0702	BOLT,8X45	2	2			
92153A	92153-1837	BOLT,SOCKET,10X60	2	2			
92153B	92153-1930	BOLT,SOCKET,10X58	1	1			
92154	92154-0907	BOLT,SOCKET,6X14	10	10			
92161	92161-0306	DAMPER	8	8			
92161A	92161-0308	DAMPER	2	2			
92161B	92161-0856	DAMPER	4	4			
92173	92173-0037	CLAMP	2	2			
92210	92210-0076	NUT,8MM	8	8			
92210A	92210-1139	NUT,LOCK,FLANGED,10MM	2	2			

E1210

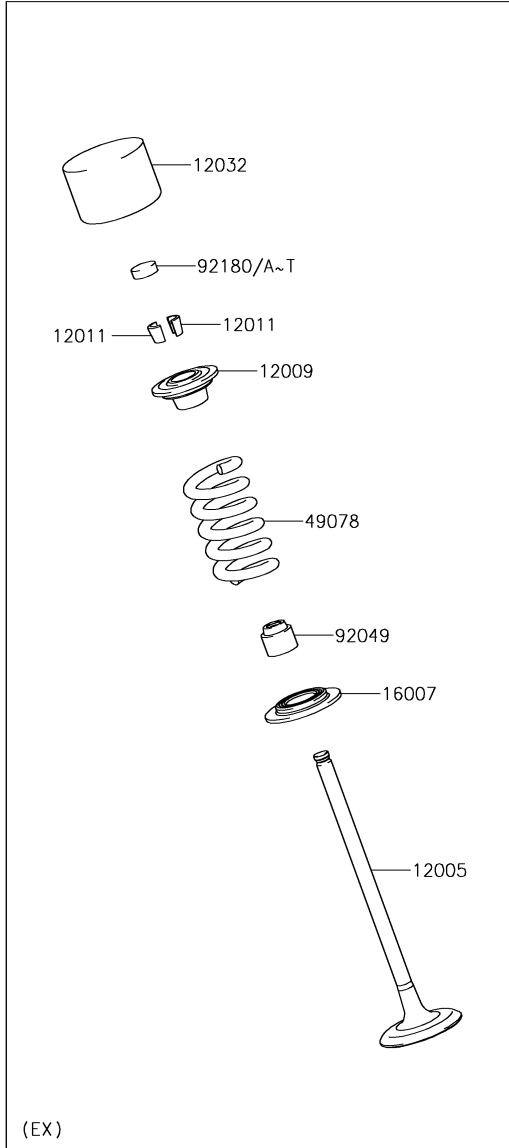

(EX)

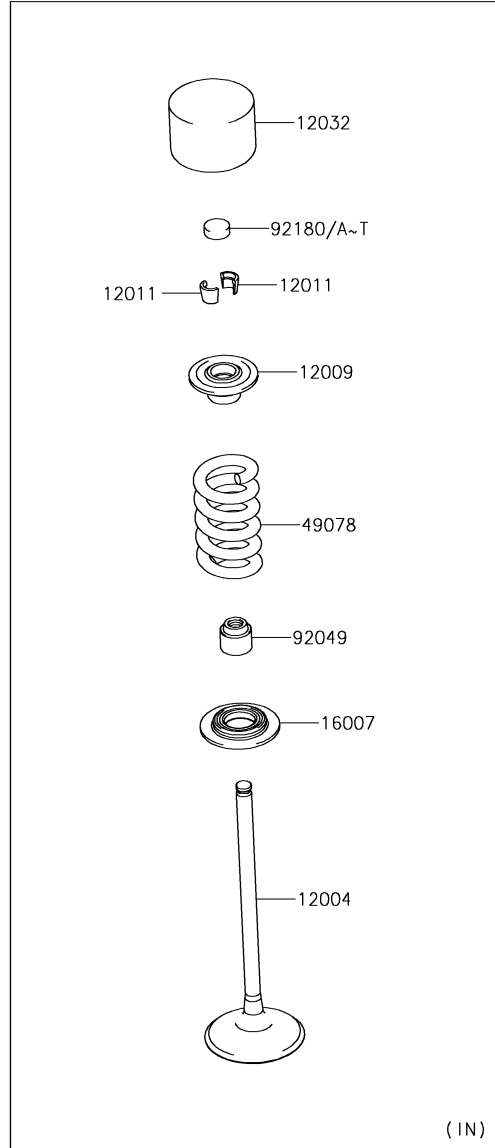

(IN)

6. Valve(s)

Ref. No.	Part No.	Description	Spec Code	Quantity			
				'17	'18		
				HHF	HJF		
12004	12004-0747	VALVE-INTAKE		8	8		
12005	12005-0768	VALVE-EXHAUST		8	8		
12009	12009-1091	RETAINER-VALVE SPRING		16	16		
12011	12011-1053	COLLET		32	32		
12032	12032-0009	TAPPET		16	16		
16007	16007-0034	SEAT-SPRING		16	16		
49078	49078-0073	SPRING-ENGINE VALVE		16	16		
92049	92049-1349	SEAL-OIL,VSB 4.3 7.5 5.3 8.3		16	16		
92180	92180-1014	SHIM,T=2.50		16	16		
92180A	92180-1016	SHIM,T=2.55		AR	AR		
92180B	92180-1018	SHIM,T=2.60		AR	AR		
92180C	92180-1020	SHIM,T=2.65		AR	AR		
92180D	92180-1022	SHIM,T=2.70		AR	AR		
92180E	92180-1024	SHIM,T=2.75		AR	AR		
92180F	92180-1026	SHIM,T=2.80		AR	AR		
92180G	92180-1028	SHIM,T=2.85		AR	AR		
92180H	92180-1030	SHIM,T=2.90		AR	AR		
92180I	92180-1032	SHIM,T=2.95		AR	AR		
92180J	92180-1034	SHIM,T=3.00		AR	AR		
92180K	92180-1036	SHIM,T=3.05		AR	AR		
92180L	92180-1038	SHIM,T=3.10		AR	AR		
92180M	92180-1040	SHIM,T=3.15		AR	AR		
92180N	92180-1042	SHIM,T=3.20		AR	AR		
92180O	92180-1044	SHIM,T=3.25		AR	AR		
92180P	92180-1046	SHIM,T=3.30		AR	AR		
92180Q	92180-1048	SHIM,T=3.35		AR	AR		
92180R	92180-1050	SHIM,T=3.40		AR	AR		
92180S	92180-1052	SHIM,T=3.45		AR	AR		
92180T	92180-1054	SHIM,T=3.50		AR	AR		

7. Camshaft(s)/Tensioner

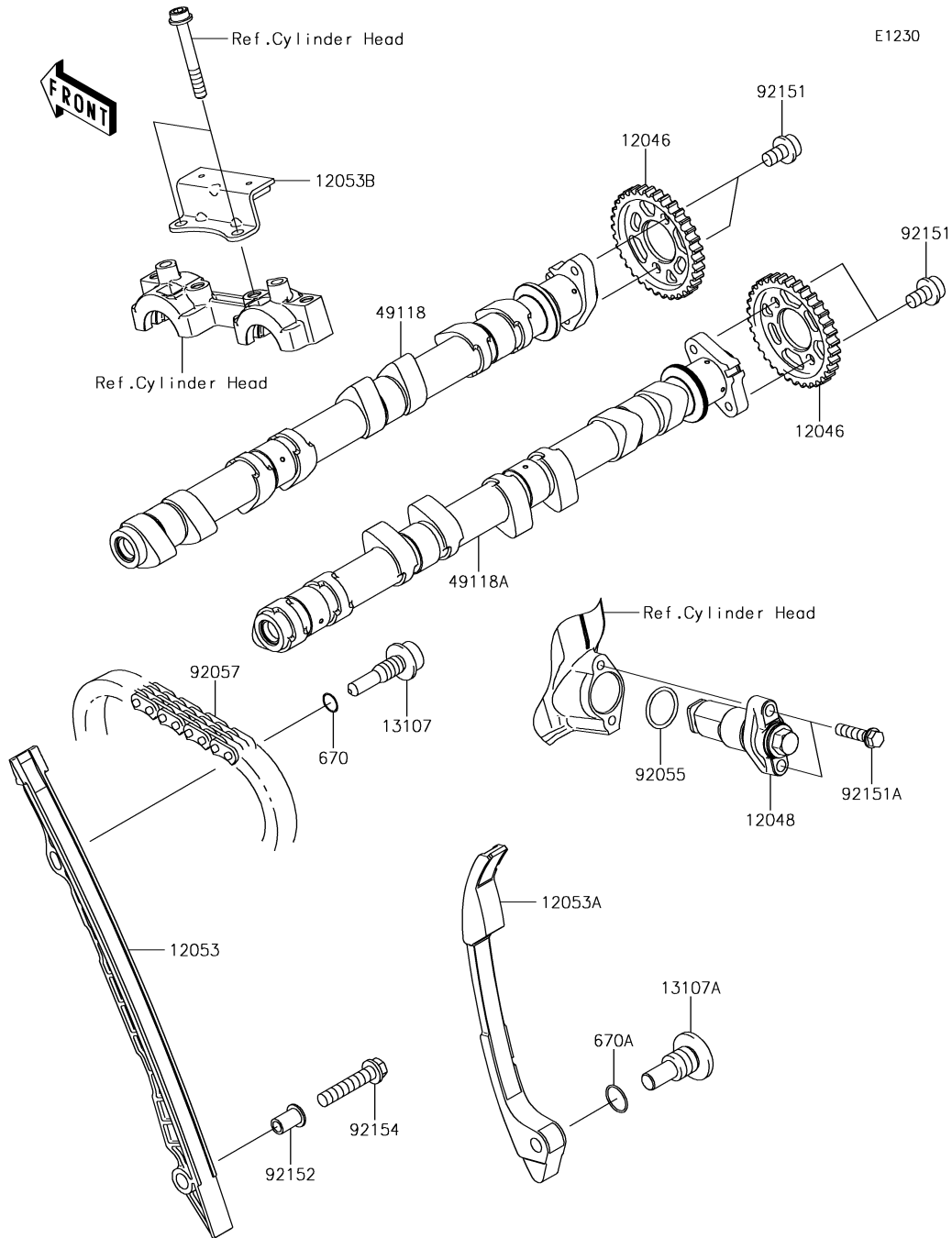

Ref. No.	Part No.	Description	Spec Code	Quantity			
				'17	'18		
				HHF	HJF		
12046	12046-0564	SPROCKET,CAMSHAFT,34T		2	2		
12048	12048-0080	TENSIONER-ASSY		1	1		
12053	12053-0161	GUIDE-CHAIN,FR		1	1		
12053A	12053-0162	GUIDE-CHAIN,RR		1	1		
12053B	12053-0163	GUIDE-CHAIN,UPP		1	1		
13107	13107-0157	SHAFT,CHAIN GUIDE		1	1		
13107A	13107-1376	SHAFT		1	1		
49118	49118-0144	CAMSHAFT-COMP,EXHAUST		1	1		
49118A	49118-0782	CAMSHAFT-COMP,INTAKE		1	1		
92055	92055-086	RING-O,18.8X1.9		1	1		
92057	92057-0202	CHAIN,98XRH2015-126M		1	1		
92151	92151-1829	BOLT,SOCKET,6X10		4	4		
92151A	92151-1930	BOLT,FLANGED-SMALL,6X25		2	2		
92152	92152-1167	COLLAR		1	1		
92154	92154-1942	BOLT,FLANGED,6X30		1	1		
670	670D1509	O RING,9MM		1	1		
670A	670D2014	O RING,14MM		1	1		

8. Crankshaft

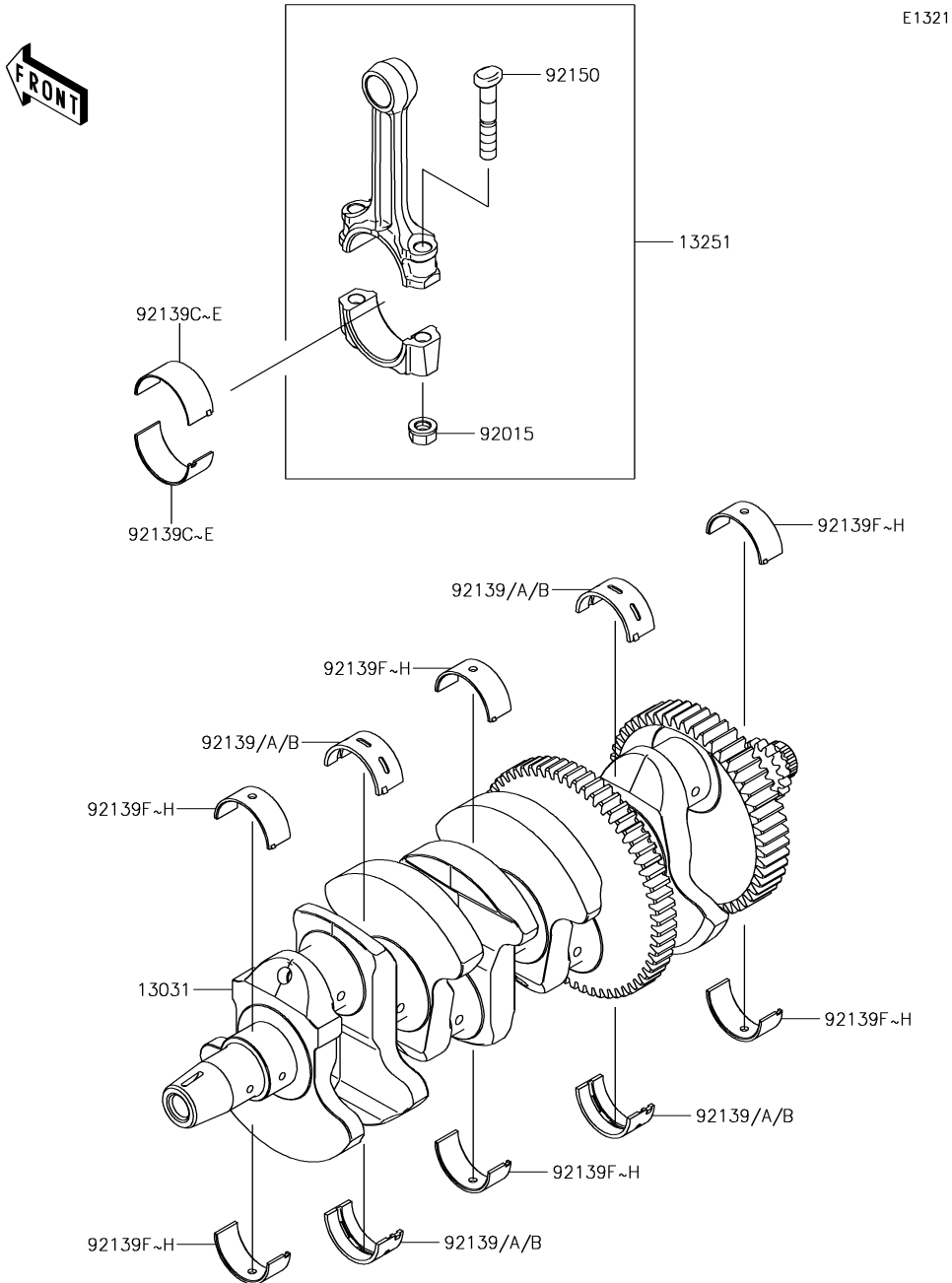

Ref. No.	Part No.	Description	Spec Code	Quantity			
				'17	'18		
				HHF	HJF		
13031	13031-0710	CRANKSHAFT-COMP		1	1		
13251	13251-0726-II	ROD-ASSY-CONNECTING,II		4	4		
92015	92015-1311	NUT,FLANGED,8MM		8	8		
92139	92139-0032	BUSHING,CRANK #2,BLUE	AR	AR			
92139A	92139-0033	BUSHING,CRANK #2,BLACK		4	4		
92139B	92139-0034	BUSHING,CRANK #2,BROWN	AR	AR			
92139C	92139-0122	BUSHING,CRANK PIN,BLUE	AR	AR			
92139D	92139-0123	BUSHING,CRANK PIN,BLACK		8	8		
92139E	92139-0124	BUSHING,CRANK PIN,BROWN	AR	AR			
92139F	92139-0217	BUSHING,CRANK,#1,BLUE	AR	AR			
92139G	92139-0218	BUSHING,CRANK,#1,BLACK		6	6		
92139H	92139-0219	BUSHING,CRANK,#1,BROWN	AR	AR			
92150	92150-1216	BOLT,CONNECTING ROD,8MM		8	8		

E1323

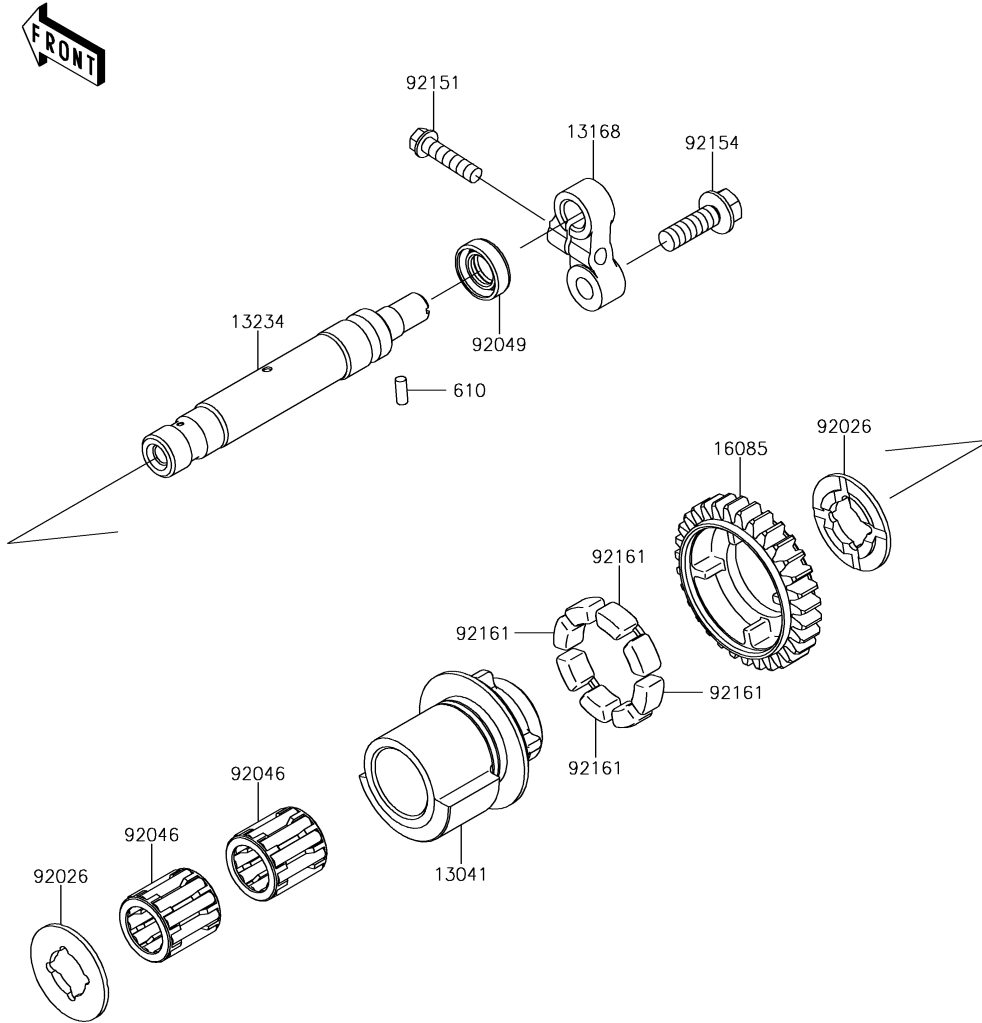

9. Balancer

Ref. No.	Part No.	Description	Spec Code	Quantity			
				'17	'18		
				HHF	HJF		
13041	13041-0040	BALANCER		1	1		
13168	13168-0115	LEVER		1	1		
13234	13234-0038	SHAFT-COMP		1	1		
16085	16085-0134	GEAR,BALANCER,31T		1	1		
92026	92026-0082	SPACER		2	2		
92046	92046-1266	BEARING-NEEDLE		2	2		
92049	92049-2204	SEAL-OIL,TC 12X22X7		1	1		
92151	92151-1930	BOLT,FLANGED-SMALL,6X25		1	1		
92154	92154-0413	BOLT,FLANGED,8X25		1	1		
92161	92161-1055	DAMPER		4	4		
610	610A0410	ROLLER,4X10		1	1		

E1350

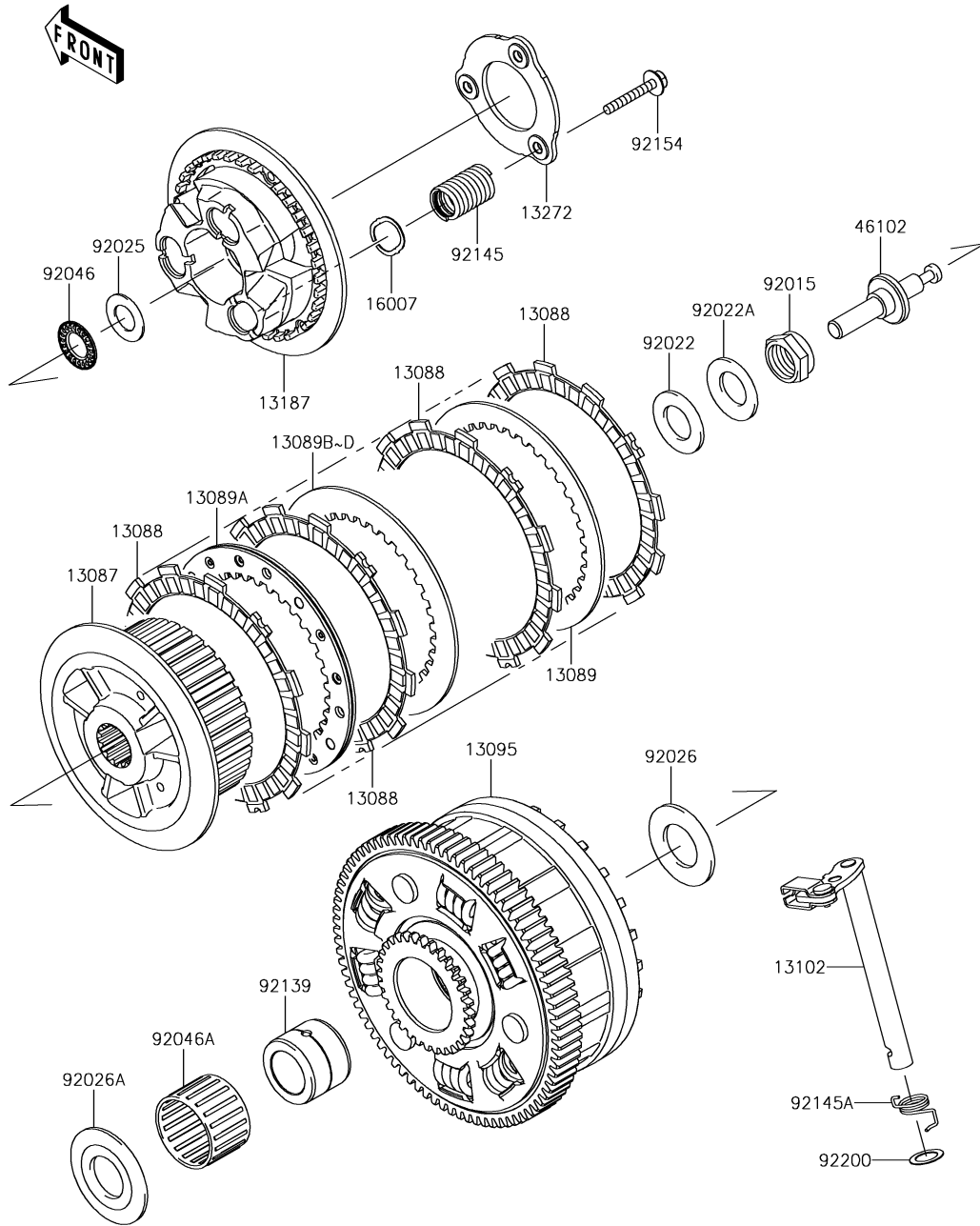

10. Clutch

Ref. No.	Part No.	Description	Spec Code	Quantity			
				'17	'18		
				HHF	HJF		
13087	13087-0583	HUB-CLUTCH		1	1		
13088	13088-0568	PLATE-FRICTION		9	9		
13089	13089-0023	PLATE-CLUTCH,T=2.3		1	1		
13089A	13089-0024	PLATE-CLUTCH,SPG COMP		1	1		
13089B	13089-1073	PLATE-CLUTCH,T=2.0	AR	AR			
13089C	13089-1084	PLATE-CLUTCH,T=2.3		6	6		
13089D	13089-1115	PLATE-CLUTCH,T=2.6	AR	AR			
13095	13095-0572	HOUSING-COMP-CLUTCH		1	1		
13102	13102-0047	RELEASE-COMP-CLUTCH		1	1		
13187	13187-0031	PLATE-CLUTCH OPERATING		1	1		
13272	13272-1413	PLATE		1	1		
16007	16007-0711	SEAT-SPRING		3	3		
46102	46102-0630	ROD		1	1		
92015	92015-1555	NUT,20MM		1	1		
92022	92022-1116	WASHER,20.3X36X2.3		1	1		
92022A	92022-1868	WASHER,20.3X36X3.7		1	1		
92025	92025-1137	SHIM,15.3X27.5X1.20		1	1		
92026	92026-022	SPACER,25.5X47X2.5		1	1		
92026A	92026-1497	SPACER		1	1		
92046	92046-1052	BEARING-NEEDLE,AXK1102		1	1		
92046A	92046-1263	BEARING-NEEDLE,K38X43X28.8X		1	1		
92139	92139-0067	BUSHING,25X38X29.05		1	1		
92145	92145-1630	SPRING		3	3		
92145A	92145-1770	SPRING,RELEASE-COMP		1	1		
92154	92154-1116	BOLT,FLANGED,6X35		3	3		
92200	92200-1487	WASHER,12X18.5X0.5		1	1		

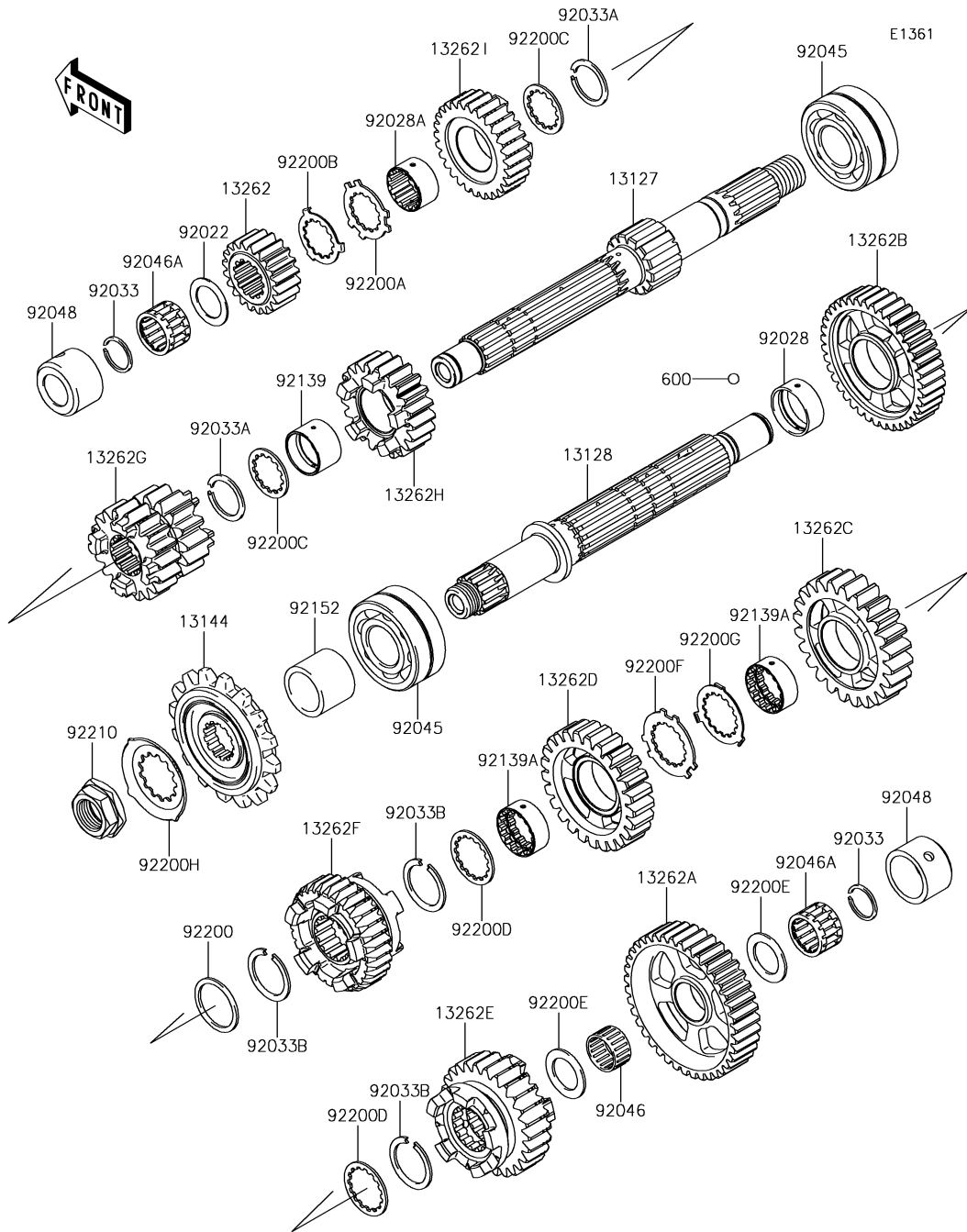

11. Transmission

Ref. No.	Part No.	Description	Spec Code	Quantity			
				'17	'18		
				HHF	HJF		
13127	13127-0073	SHAFT-TRANSMISSION INPUT		1	1		
13128	13128-0054	SHAFT-TRANSMISSION OUTPUT		1	1		
13144	13144-0070	SPROCKET-OUTPUT,15T		1	1		
13262	13262-0753	GEAR,INPUT 2ND,20T		1	1		
13262A	13262-1255	GEAR,OUTPUT LOW,39T		1	1		
13262B	13262-1256	GEAR,OUTPUT 2ND,39T		1	1		
13262C	13262-1257	GEAR,OUTPUT 3RD,24T		1	1		
13262D	13262-1258	GEAR,OUTPUT 4TH,25T		1	1		
13262E	13262-1259	GEAR,OUTPUT 5TH,26T		1	1		
13262F	13262-1260	GEAR,OUTPUT TOP,31T		1	1		
13262G	13262-1270	GEAR,INPUT 3RD&4TH,15T&18T		1	1		
13262H	13262-1271	GEAR,INPUT 5TH,21T		1	1		
13262I	13262-1272	GEAR,INPUT TOP,28T		1	1		
92022	92022-112	WASHER,20.5X30X1,STEEL		1	1		
92028	92028-1739	BUSHING,OUTPUT,2ND		1	1		
92028A	92028-1915	BUSHING,INPUT TOP GEAR		1	1		
92033	92033-015	RING-SNAP,20MM		2	2		
92033A	92033-026	RING-SNAP,24MM		2	2		
92033B	92033-1249	RING-SNAP,T=1.5		3	3		
92045	92045-0003	BEARING-BALL,DAC2557NSSH		2	2		
92046	92046-1219	BEARING-NEEDLE,K20X24X13		1	1		
92046A	92046-1303	BEARING-NEEDLE,PK20X27X17X3		2	2		
92048	92048-0016	RACE		2	2		
92139	92139-0280	BUSHING,25X28X17.8		1	1		
92139A	92139-0281	BUSHING,OUTPUT,3RD&4TH		2	2		
92152	92152-0812	COLLAR,SPROCKET		1	1		
92200	92200-0228	WASHER,28.1X34.0X1.6		1	1		
92200A	92200-0520	WASHER,25.2X34.2X1.5		1	1		
92200B	92200-0521	WASHER,25.2X32X1		1	1		
92200C	92200-1239	WASHER,25.2X31.0X1.5		2	2		
92200D	92200-1240	WASHER,28.5X34.0X1.5		2	2		
92200E	92200-1375	WASHER,20.5X31X1.5		2	2		
92200F	92200-1522	WASHER,25.8X40.5X1.5		1	1		
92200G	92200-1523	WASHER,25.2X37.0X1.0		1	1		
92200H	92200-1720	WASHER		1	1		
92210	92210-0850	NUT,20MM		1	1		
600	600A0500	BALL-STEEL,5/32		3	3		

E1362

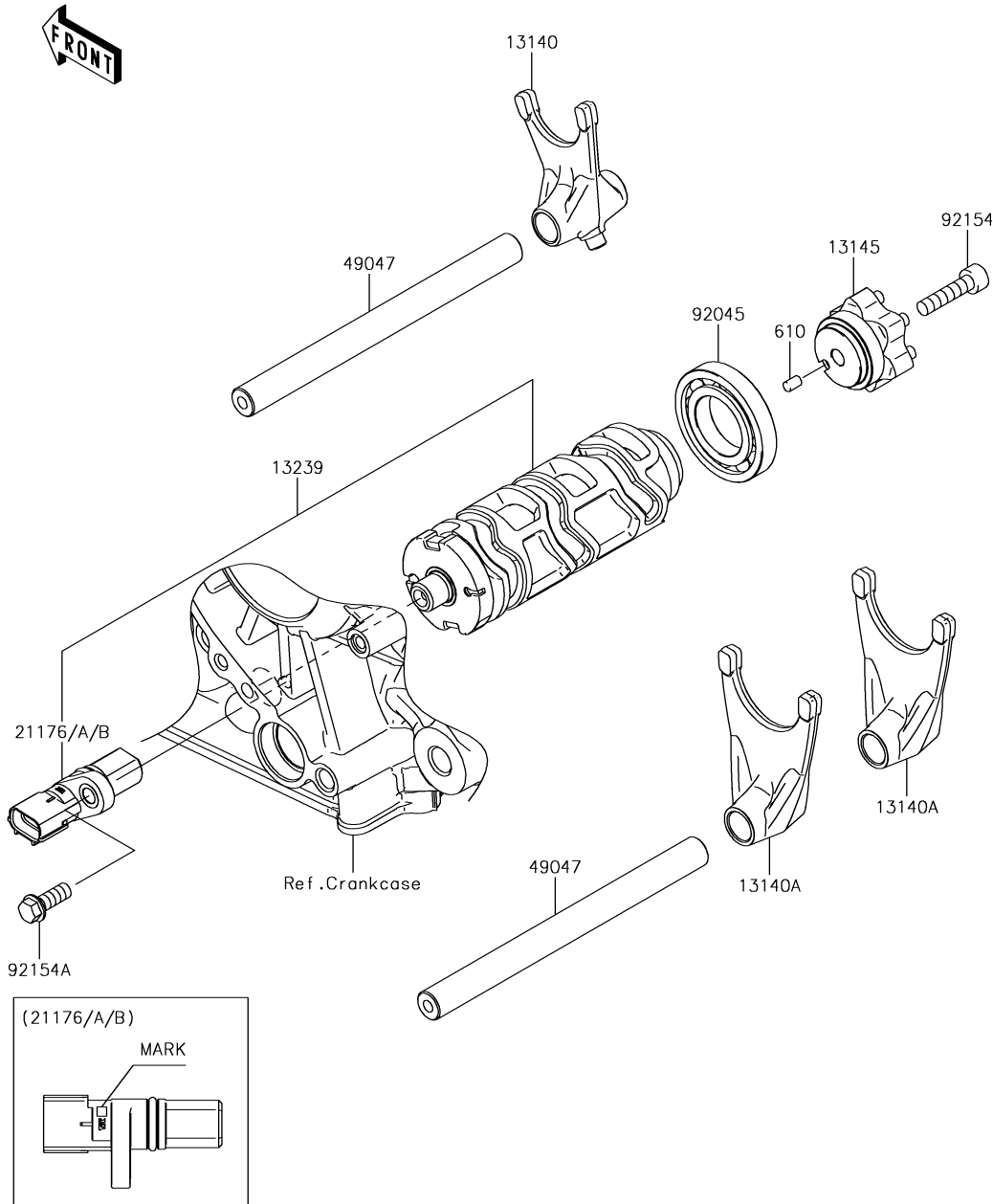

12. Gear Change Drum/Shift Fork(s)

Ref. No.	Part No.	Description	Spec Code	Quantity			
				'17	'18		
				HHF	HJF		
13140	13140-0061	FORK-SHIFT		1	1		
13140A	13140-0062	FORK-SHIFT		2	2		
13145	13145-0048	CAM-CHANGE DRUM		1	1		
13239	13239-0577	DRUM-ASSY-CHANGE		1	1		
21176	21176-0825	SENSOR,GEAR POSITION,M MARK		1	1		
21176A	21176-0845	SENSOR,GEAR POSITION,H MARK		1	1		
21176B	21176-0846	SENSOR,GEAR POSITION,L MARK		1	1		
49047	49047-0023	ROD-SHIFT		2	2		
92045	92045-1045	BEARING-BALL,16005		1	1		
92154	92154-0477	BOLT,SOCKET,6X25		1	1		
92154A	92154-2096	BOLT,FLANGED,6X16		1	1		
610	610A0406	ROLLER,4X6		1	1		

E1370

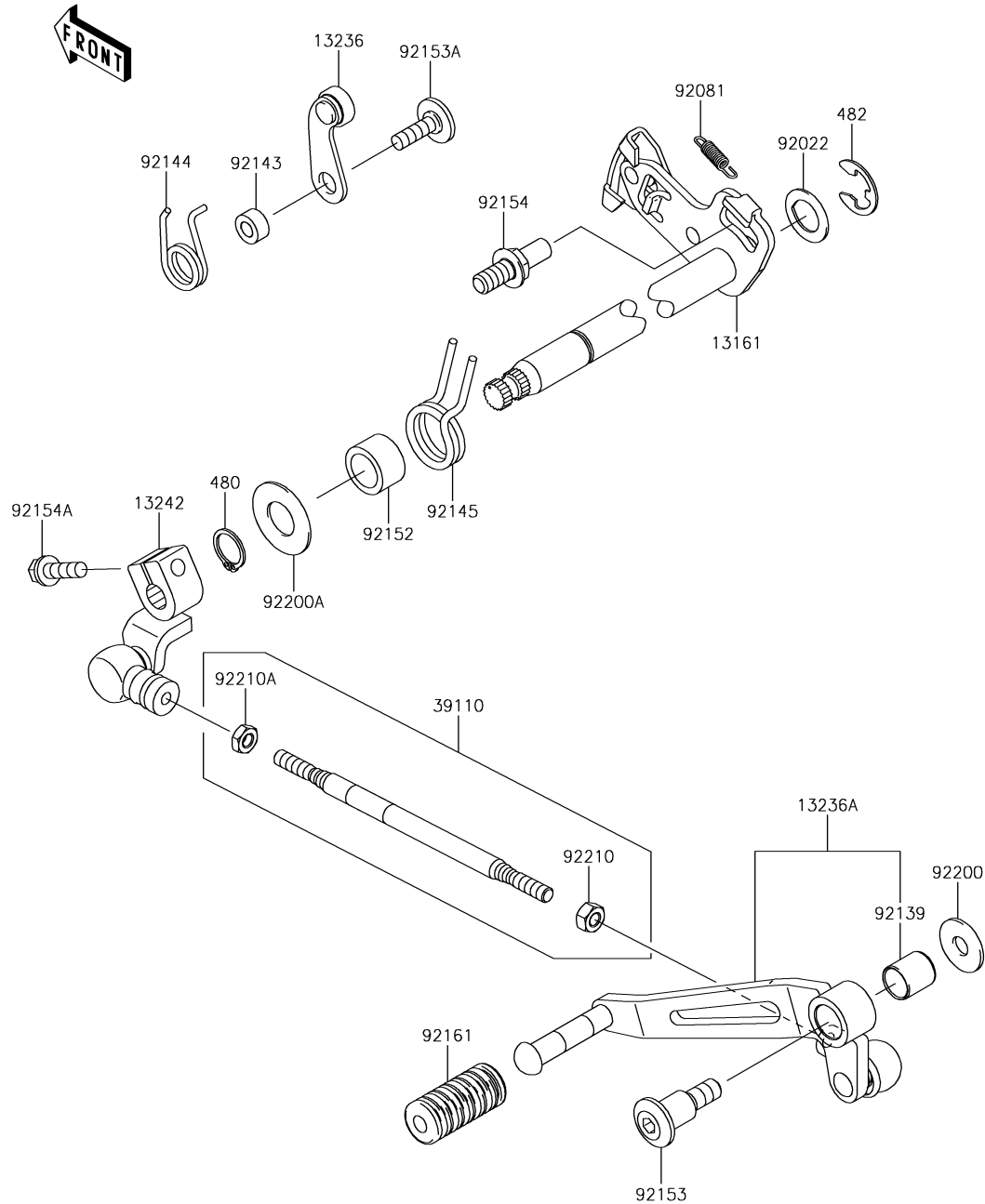

13. Gear Change Mechanism

Ref. No.	Part No.	Description	Spec Code	Quantity			
				'17	'18		
				HHF	HJF		
13161	13161-0592	LEVER-COMP-CHANGE SHAFT		1	1		
13236	13236-0068	LEVER-COMP		1	1		
13236A	13236-0788	LEVER-COMP,CHANGE PEDAL		1	1		
13242	13242-0139	LEVER-ASSY-CHANGE		1	1		
39110	39110-0033	ROD-ASSY-TIE		1	1		
92022	92022-1628	WASHER,CHANGE SHAFT		1	1		
92081	92081-1708	SPRING,PAWL RETURN		1	1		
92139	92139-0023	BUSHING		1	1		
92143	92143-1595	COLLAR		1	1		
92144	92144-1523	SPRING,GEAR POSITION		1	1		
92145	92145-1122	SPRING		1	1		
92152	92152-1383	COLLAR,14.2X19.9X12.0		1	1		
92153	92153-0446	BOLT,SOCKET,8X16.7		1	1		
92153A	92153-1505	BOLT,6X20		1	1		
92154	92154-1838	BOLT,RETURN SPRING		1	1		
92154A	92154-2090	BOLT,FLANGED,6X20		1	1		
92161	92161-1300	DAMPER,CHANGE PEDAL		1	1		
92200	92200-0174	WASHER,8.0X22.0X1.5		1	1		
92200A	92200-0265	WASHER		1	1		
92210	92210-1100	NUT,6MM		1	1		
92210A	92210-1101	NUT,LEFT HANDED,6MM		1	1		
480	480J1400	CIRCLIP-TYPE-C,14MM		1	1		
482	482J0200	CIRCLIP-TYPE-E,12MM		1	1		

14. Crankcase

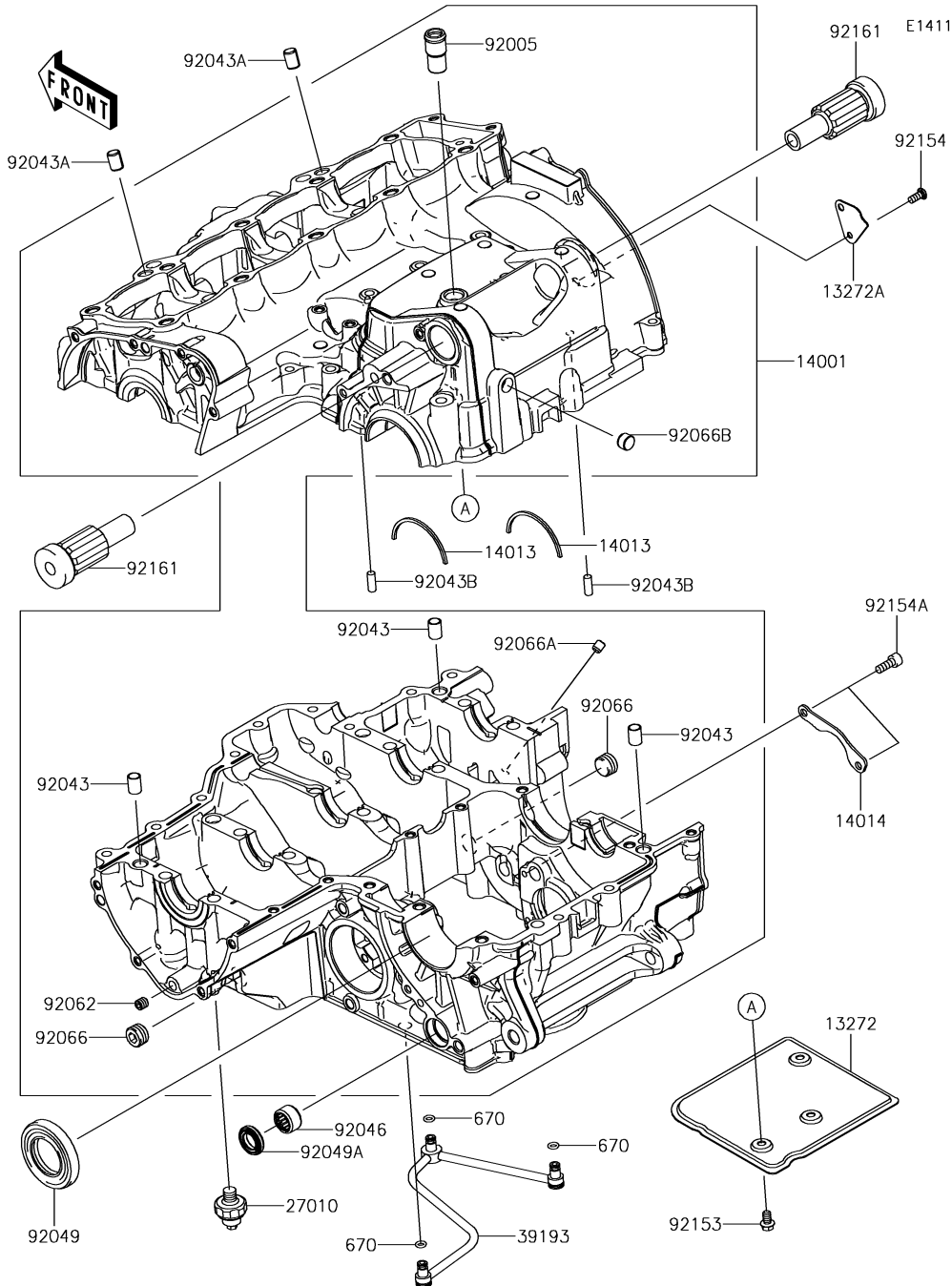

Ref. No.	Part No.	Description	Spec Code	Quantity			
				'17	'18		
				HHF	HJF		
13272	13272-0698	PLATE,BREATHER,UPP	1	1			
13272A	13272-0699	PLATE,BREATHER,SIDE	1	1			
14001	14001-0670	SET-CRANKCASE	1	1			
14013	14013-1051	RING-POSITION	2	2			
14014	14014-0036	PLATE-POSITION	1	1			
27010	27010-1313	SWITCH,OIL PRESSURE	1	1			
39193	39193-0054	PIPE-OIL	1	1			
92005	92005-1238	FITTING,BREATHER	1	1			
92043	92043-1037	PIN,DOWEL,10X14	3	3			
92043A	92043-1264	PIN,8.2X10X14	2	2			
92043B	92043-1690	PIN,6X16	2	2			
92046	92046-0043	BEARING-NEEDLE,HK1412FM	1	1			
92049	92049-1474	SEAL-OIL,TC32578	1	1			
92049A	92049-1520	SEAL-OIL,TC14245	1	1			
92062	92062-0046	NOZZLE	1	1			
92066	92066-0836	PLUG	2	2			
92066A	92066-1012	PLUG,OIL LINE,7.2X8	1	1			
92066B	92066-1110	PLUG	1	1			
92153	92153-0381	BOLT,6X10	3	3			
92154	92154-0299	BOLT,TORX,5X12	1	1			
92154A	92154-0484	BOLT,SOCKET,6X16	2	2			
92161	92161-0801	DAMPER	2	2			
670	670D1505	O RING	3	3			

15. Crankcase Bolt Pattern

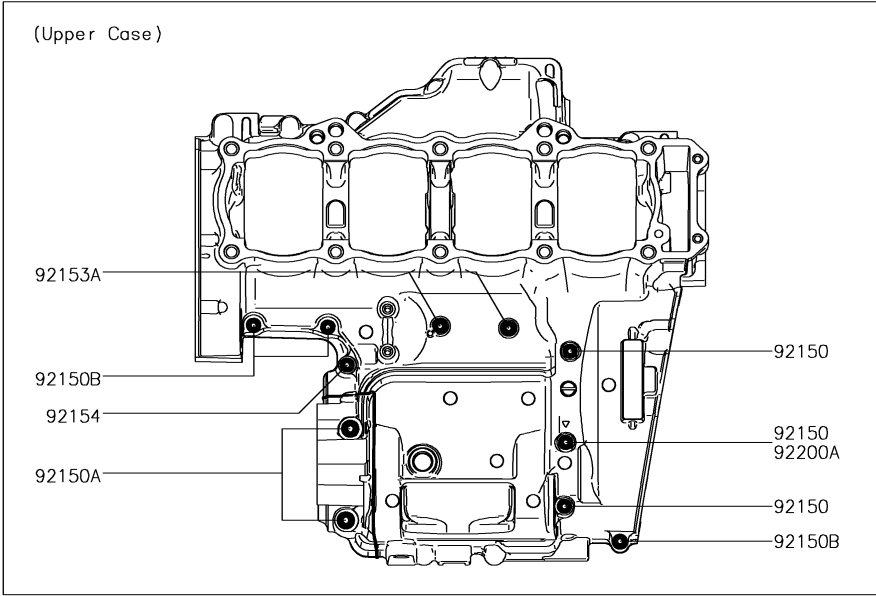

E1412

Ref. No.	Part No.	Description	Spec Code	Quantity			
				'17	'18		
				HHF	HJF		
92150	92150-1251	BOLT,FLANGED,7X85		3	3		
92150A	92150-1483	BOLT,8X70		2	2		
92150B	92150-1794	BOLT,6X40		3	3		
92151	92151-1539	BOLT,FLANGED,7X45		8	8		
92153	92153-1045	BOLT,FLANGED,7X60		1	1		
92153A	92153-1637	BOLT,FLANGED,6X68		2	2		
92154	92154-0372	BOLT,FLANGED,7X50		3	3		
92154A	92154-2639	BOLT,FLANGED,9X100		4	4		
92154B	92154-2640	BOLT,FLANGED,9X90		6	6		
92200	92200-0115	WASHER,9.2X19X2.3		10	10		
92200A	92200-0556	WASHER		2	2		

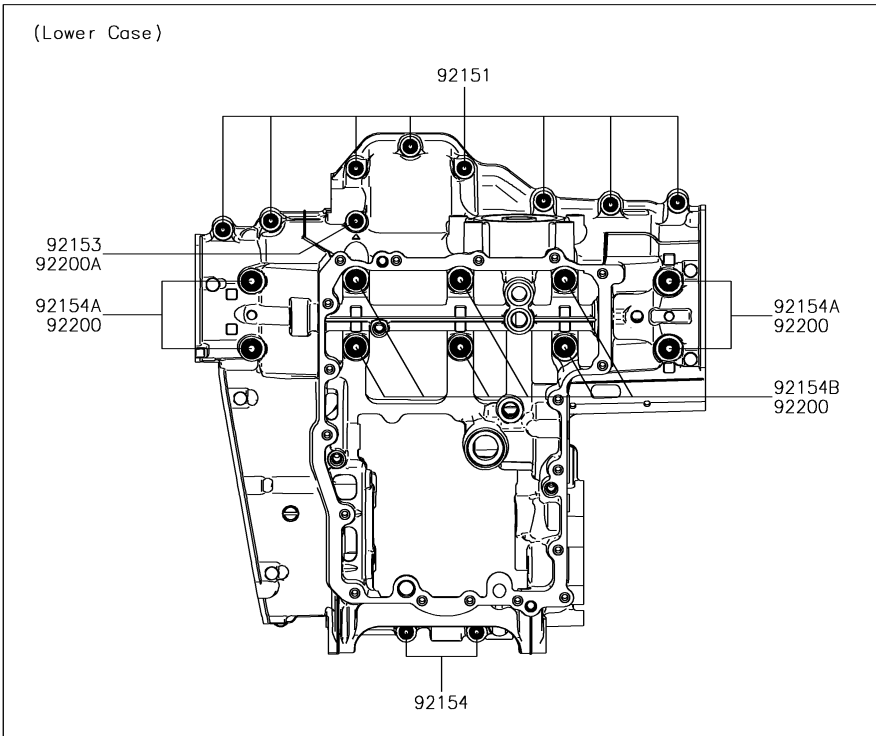

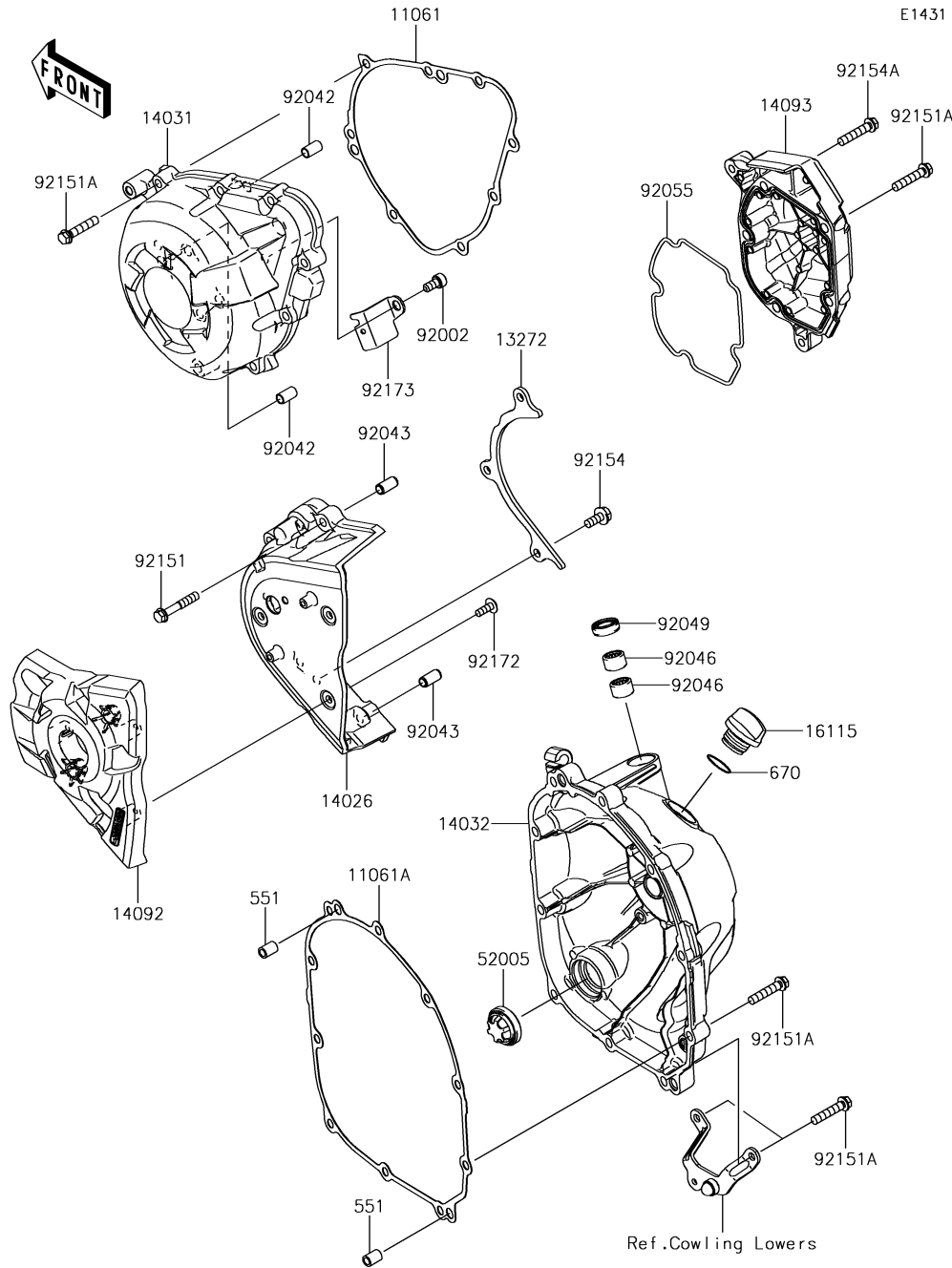

16. Engine Cover(s)

Ref. No.	Part No.	Description	Spec Code	Quantity			
				'17	'18		
				HHF	HJF		
11061	11061-0403	GASKET,GENERATOR COVER		1	1		
11061A	11061-0404	GASKET,CLUTCH COVER		1	1		
13272	13272-0859	PLATE		1	1		
14026	14026-0135	COVER-CHAIN		1	1		
14031	14031-0610	COVER-GENERATOR		1	1		
14032	14032-0631	COVER-CLUTCH		1	1		
14092	14092-0032	COVER,OUTER		1	1		
14093	14093-0543	COVER,PULSER		1	1		
16115	16115-1053	CAP-OIL FILLER		1	1		
52005	52005-1120	GAUGE		1	1		
92002	92002-1796	BOLT,SOCKET,6X12		1	1		
92042	92042-007	PIN,DOWEL,6.3X8X14		2	2		
92043	92043-1263	PIN,6.2X8X14		2	2		
92046	92046-0034	BEARING-NEEDLE,HK1210FM		2	2		
92049	92049-1475	SEAL-OIL,CLUTCH RELEASE		1	1		
92055	92055-0199	RING-O,PULSER COVER		1	1		
92151	92151-1135	BOLT,6X35		4	4		
92151A	92151-1873	BOLT,6X30		22	22		
92154	92154-0482	BOLT,FLANGED,6X14		3	3		
92154A	92154-2652	BOLT,6X30		1	1		
92172	92172-0265	SCREW,TAPPING,5X14		3	3		
92173	92173-1321	CLAMP		1	1		
551	551A0814	PIN-DOWEL,8X14		2	2		
670	670B2020	O RING,20MM		1	1		

E1434

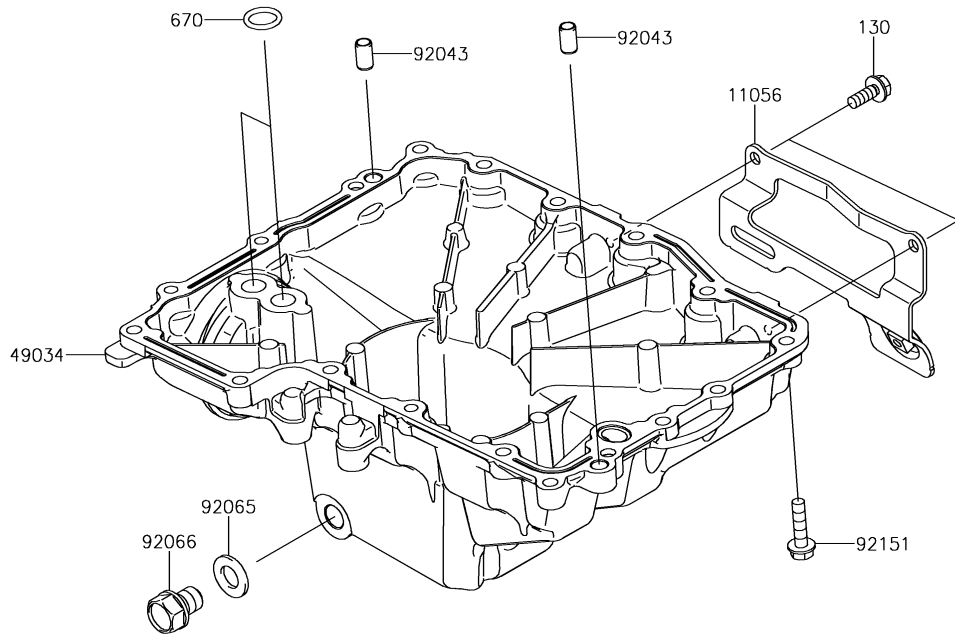

17. Oil Pan

Ref. No.	Part No.	Description	Spec Code	Quantity			
				'17	'18		
				HHF	HJF		
11056	11056-2479	BRACKET		1	1		
49034	49034-0049	PAN-OIL		1	1		
92043	92043-1263	PIN,6.2X8X14		2	2		
92065	92065-097	GASKET,12X22X2		1	1		
92066	92066-0079	PLUG,12X15		1	1		
92151	92151-1225	BOLT,FLANGED,6X25		18	18		
130	130CA0616	BOLT-FLANGED,6X16		2	2		
670	670D2014	O RING,14MM		2	2		

'17-'18 ZR1000 HHF/HJF

E 1510

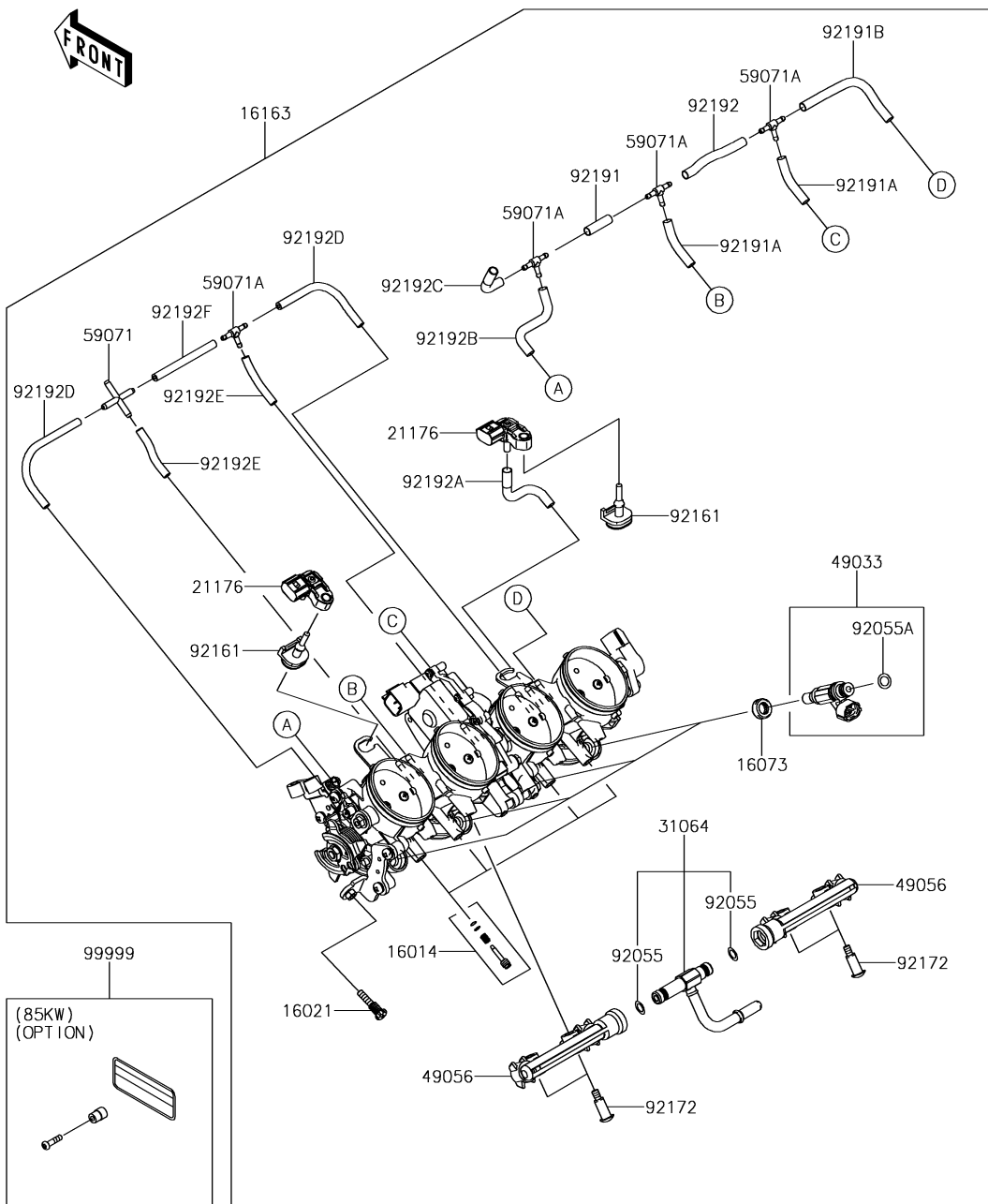

18. Throttle

Ref. No.	Part No.	Description	Spec Code	Quantity			
				'17	'18		
				HHF	HJF		
16014	16014-0002	SCREW-PILOT AIR		4	4		
16021	16021-0025	SCREW-THROTTLE STOP		1	1		
16073	16073-3707	INSULATOR		4	4		
16163	16163-0902	THROTTLE-ASSY		1	1		
21176	21176-0111	SENSOR,PRESSURE		2	2		
31064	31064-0199	PIPE-COMP,FUEL		1	1		
49033	49033-0012	NOZZLE-INJECTION		4	4		
49056	49056-0014	PIPE-INJECTION		2	2		
59071	59071-0014	JOINT,4WAY		1	1		
59071A	59071-3752	JOINT,3WAY,T		4	4		
92055	92055-0064	RING-O		2	2		
92055A	92055-1622	RING-O,INJECTION NOZZLE		4	4		
92161	92161-0673	DAMPER		2	2		
92172	92172-0064	SCREW,PIPE INJECTION		4	4		
92191	92191-0020	TUBE,3X7X25		1	1		
92191A	92191-0022	TUBE,3X7X40		2	2		
92191B	92191-0023	TUBE,3X7X100		1	1		
92192	92192-0739	TUBE,3X7X72		1	1		
92192A	92192-0840	TUBE,THROBO RH-SENSOR		1	1		
92192B	92192-0841	TUBE,THROBO LH-JOINT		1	1		
92192C	92192-0842	TUBE,SENSOR-JOINT		1	1		
92192D	92192-1258	TUBE,3X6X100		2	2		
92192E	92192-1259	TUBE,3X6X40		2	2		
92192F	92192-1260	TUBE,3X6X70		1	1		
99999	99999-0572	KIT,85KW (OPTION)		1	1		

19. Fuel Pump

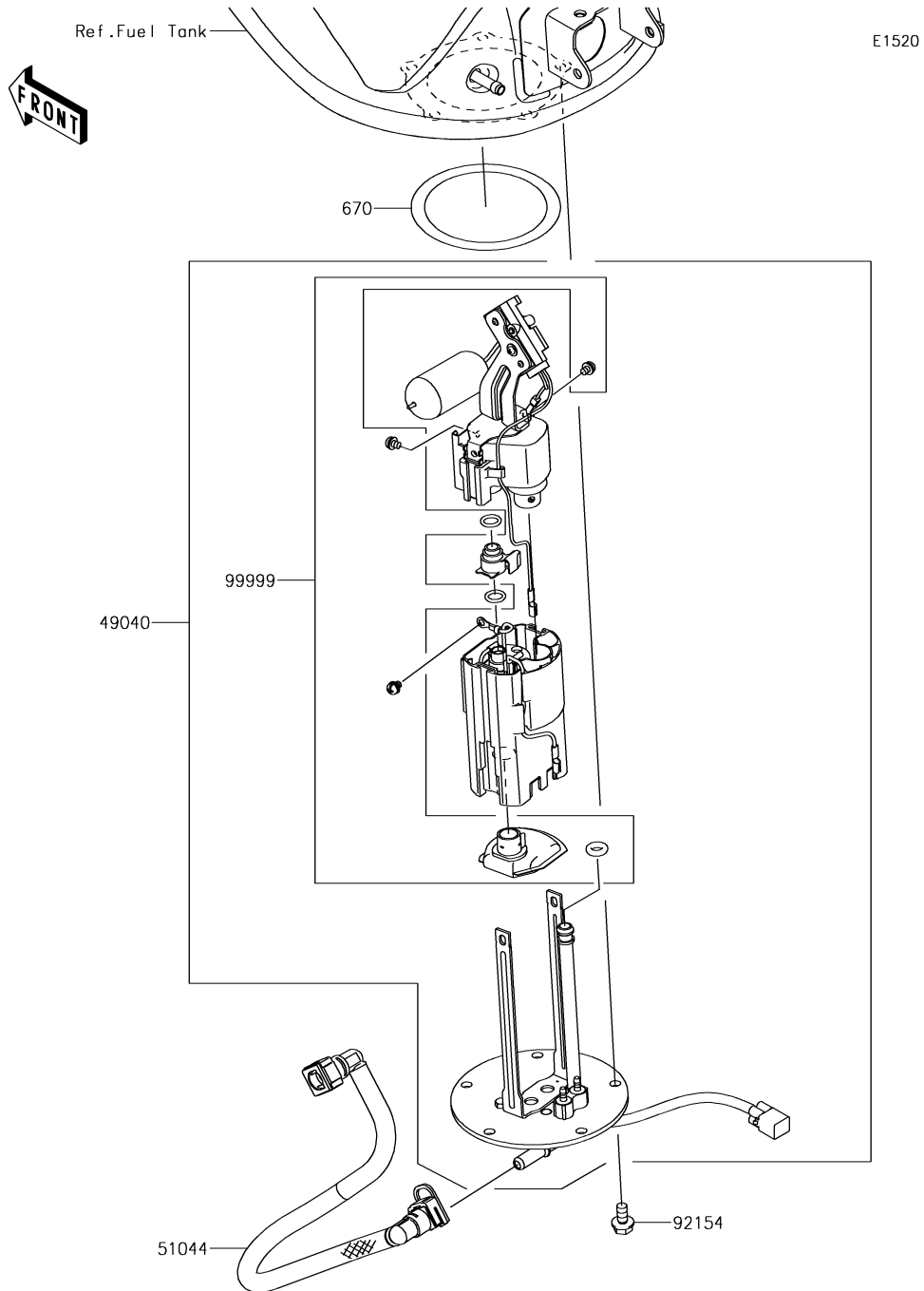

Ref. No.	Part No.	Description	Spec Code	Quantity			
				'17	'18		
				HHF	HJF		
49040	49040-0729	PUMP-FUEL		1	1		
51044	51044-0862	TUBE-ASSY,FUEL		1	1		
92154	92154-1848	BOLT,FLANGED,6X12		5	5		
99999	99999-0522	KIT,FUEL FILTER		1	1		
670	670E5075	O RING		1	1		

E1530

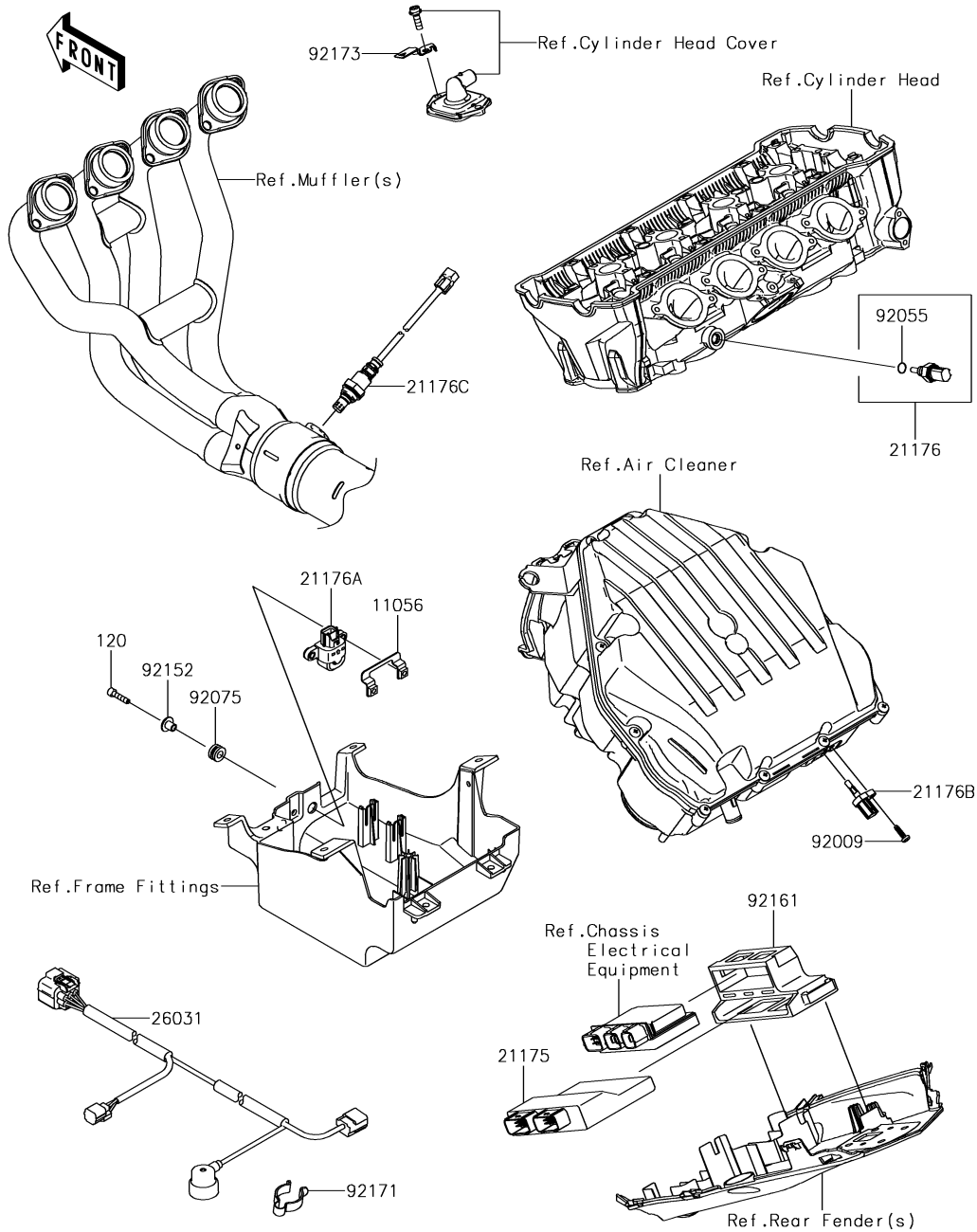

20. Fuel Injection

Ref. No.	Part No.	Description	Spec Code	Quantity			
				'17	'18		
				HHF	HJF		
11056	11056-0124	BRACKET		1	1		
21175	21175-1213	CONTROL UNIT-ELECTRONIC		1	1		
21176	21176-0009	SENSOR,WATER TEMP		1	1		
21176A	21176-0026	SENSOR,VEHICLE-DOWN		1	1		
21176B	21176-0048	SENSOR,AIR TEMPERATURE		1	1		
21176C	21176-0132	SENSOR,OXYGEN		1	1		
26031	26031-2160	HARNES, SUB		1	1		
92009	92009-1984	SCREW,TAPPING,5X16		1	1		
92055	92055-0016	RING-O,9.5X1.9		1	1		
92075	92075-1912	DAMPER		2	2		
92152	92152-0134	COLLAR		2	2		
92161	92161-0356	DAMPER		1	1		
92171	92171-1283	CLAMP,CABLE		1	1		
92173	92173-0126	CLAMP		1	1		
120	120CA0525	BOLT-SOCKET,5X25		2	2		

E1650

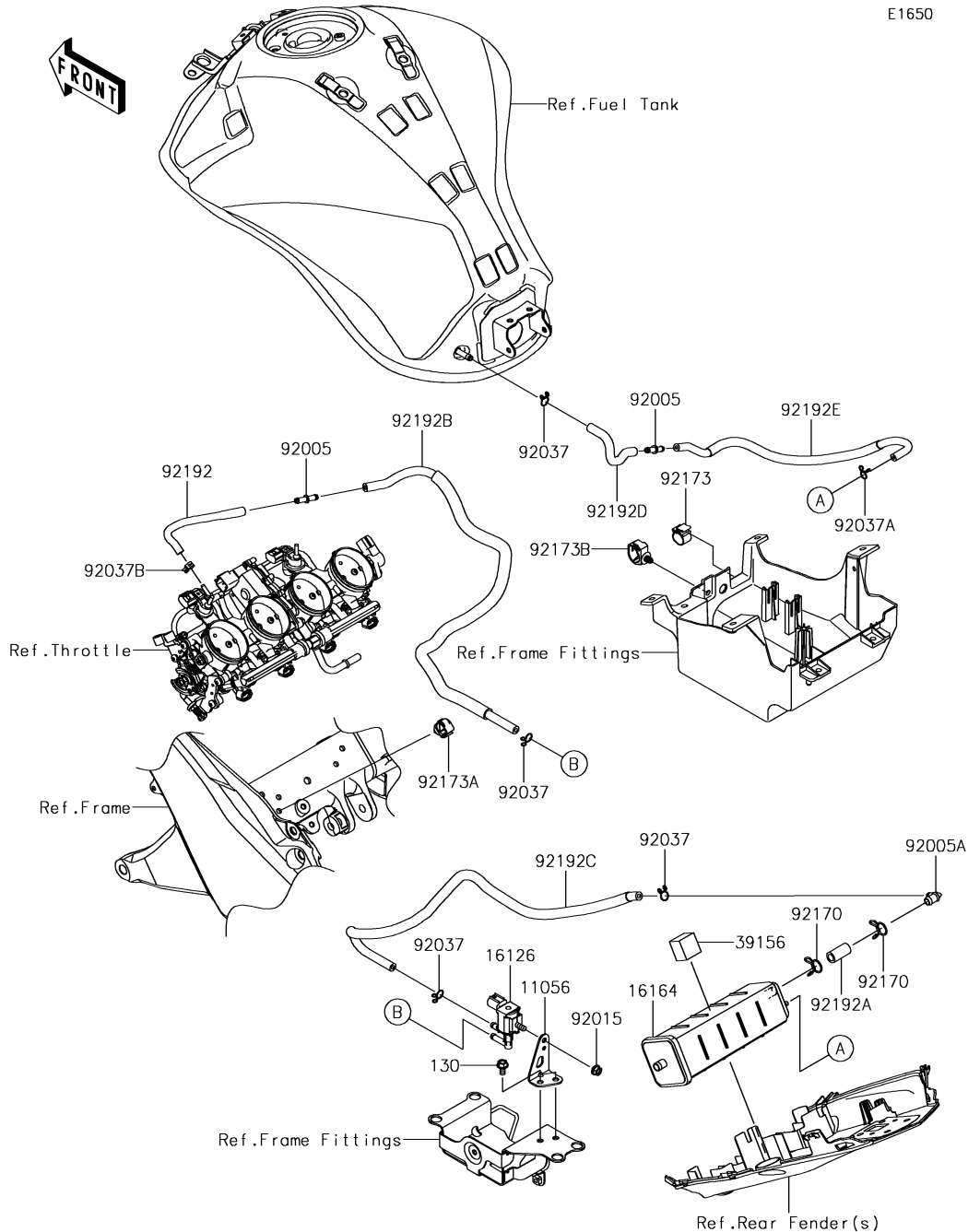

21. Fuel Evaporative System

Ref. No.	Part No.	Description	Spec Code	Quantity			
				'17	'18		
				HHF	HJF		
11056	11056-2480	BRACKET, VALVE	1	1			
16126	16126-0705	VALVE, SOLENOID	1	1			
16164	16164-0009	CANISTER	1	1			
39156	39156-1774	PAD, CANISTER	1	1			
92005	92005-0721	FITTING	2	2			
92005A	92005-0753	FITTING	1	1			
92015	92015-1367	NUT, FLANGED, 6MM	1	1			
92037	92037-147	CLAMP, TUBE	4	4			
92037A	92037-1712	CLAMP	1	1			
92037B	92037-2116	CLAMP, 7.8MM	1	1			
92170	92170-1695	CLAMP	2	2			
92173	92173-0127	CLAMP, CLIP	1	1			
92173A	92173-0736	CLAMP, 12MM DIA.	1	1			
92173B	92173-0861	CLAMP	1	1			
92192	92192-1717	TUBE, THROTTLE-FITTING (VALVE)	1	1			
92192A	92192-1757	TUBE, 9X14.4X30	1	1			
92192B	92192-1758	TUBE, FITTING (THROTTLE)-VALVE	1	1			
92192C	92192-1759	TUBE, VALVE-CANISTER	1	1			
92192D	92192-1760	TUBE, FITTING (CANISTER)-TANK	1	1			
92192E	92192-1761	TUBE, CANISTER-FITTING (TANK)	1	1			
130	130BA0612	BOLT-FLANGED, 6X12	2	2			

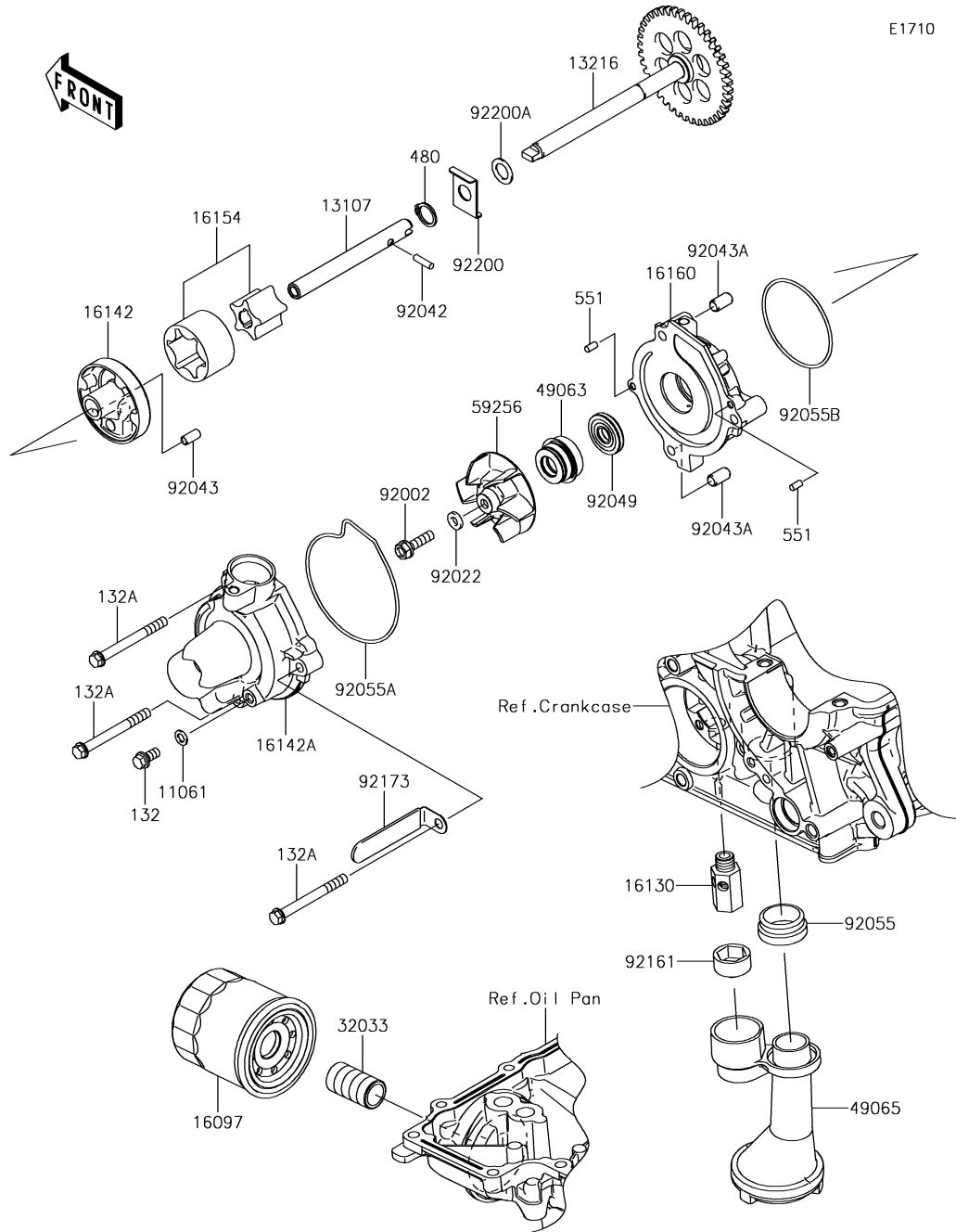

E1710

Ref. No.	Part No.	Description	Spec Code	Quantity			
				'17	'18		
				HHF	HJF		
11061	11061-0107	GASKET	1	1			
13107	13107-0214	SHAFT	1	1			
13216	13216-0020	GEAR-COMP,OIL PUMP,41T	1	1			
16097	16097-0008	FILTER-ASSY-OIL	1	1			
16130	16130-1058	VALVE-ASSY-RELIEF	1	1			
16142	16142-0064	COVER-PUMP	1	1			
16142A	16142-0746	COVER-PUMP	1	1			
16154	16154-0057	ROTOR-PUMP	1	1			
16160	16160-0796	BODY	1	1			
32033	32033-1535	PIPE,OIL FILTER	1	1			
49063	49063-1055	SEAL-MECHANICAL,WATER	1	1			
49065	49065-0026	FILTER-OIL	1	1			
59256	59256-0555	IMPELLER	1	1			
92002	92002-1154	BOLT,6X22	1	1			
92022	92022-077	WASHER,6.1X12X1	1	1			
92042	92042-030	PIN,DOWEL,4X13.8	1	1			
92043	92043-1262	PIN,4.2X6X12	1	1			
92043A	92043-1263	PIN,6.2X8X14	2	2			
92049	92049-0798	SEAL-OIL	1	1			
92055	92055-1503	RING-O,OIL FILTER	1	1			
92055A	92055-1571	RING-O,WATER PUMP COVER	1	1			
92055B	92055-3018	RING-O,59.6X2.4	1	1			
92161	92161-0070	DAMPER	1	1			
92173	92173-1201	CLAMP	1	1			
92200	92200-0410	WASHER	1	1			
92200A	92200-1009	WASHER	1	1			
132	132BA0612	BOLT-FLANGED-SMALL,6X12	1	1			
132A	132BC0660	BOLT-FLANGED-SMALL,6X60	3	3			
480	480J1100	CIRCLIP-TYPE-C,11MM	1	1			
551	551A0408	PIN-DOWEL,4X8	2	2			

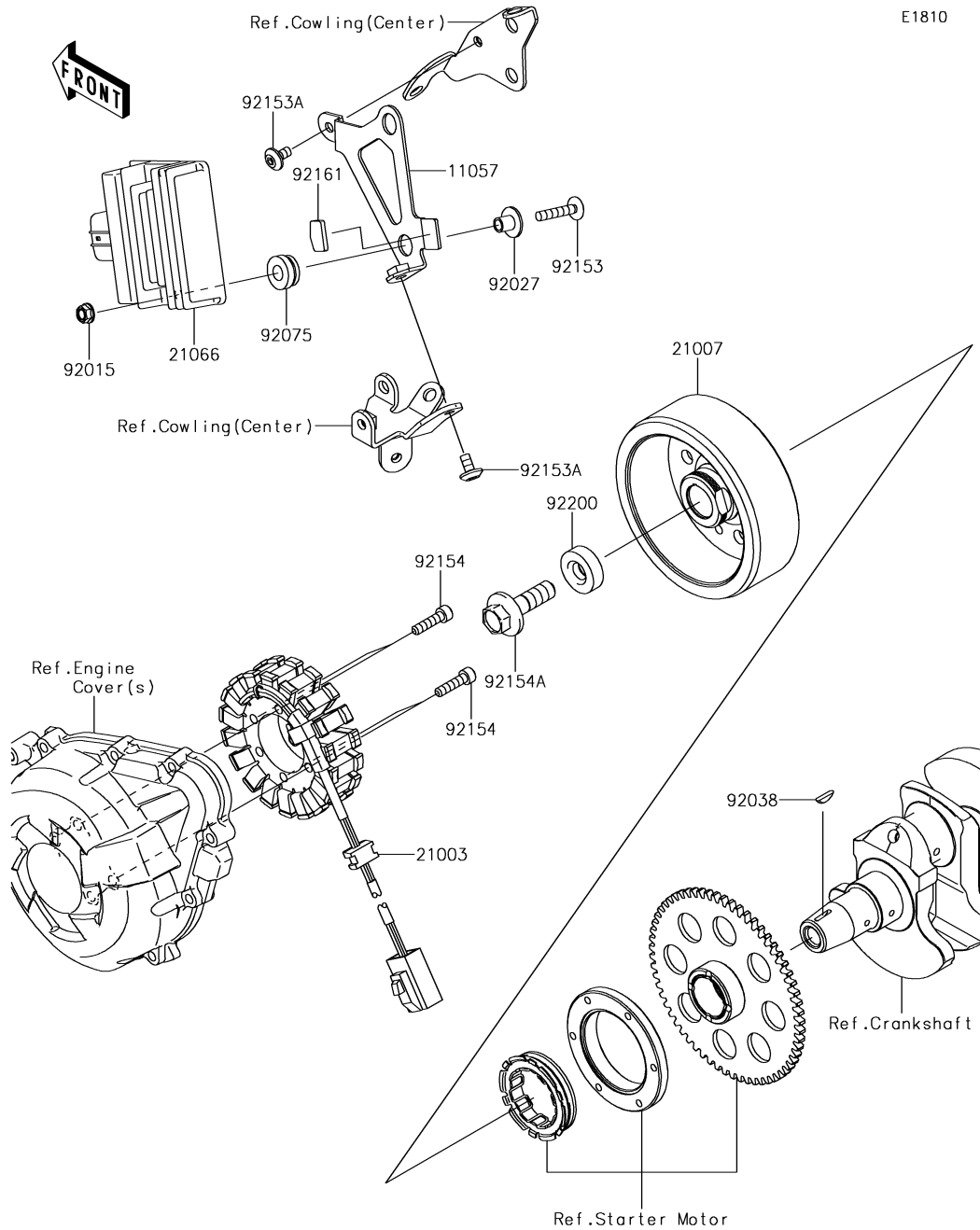

23. Generator

Ref. No.	Part No.	Description	Spec Code	Quantity			
				'17	'18		
				HHF	HJF		
11057	11057-0290	BRACKET,REGULATOR	1	1			
21003	21003-0172	STATOR	1	1			
21007	21007-0646	ROTOR	1	1			
21066	21066-0756	REGULATOR-VOLTAGE	1	1			
92015	92015-1233	NUT,FLANGED,6MM,BLACK	2	2			
92027	92027-1651	COLLAR,FLANGED,L=12.1,BLACK	2	2			
92038	92038-1060	KEY	1	1			
92075	92075-277	DAMPER	2	2			
92153	92153-1528	BOLT,SOCKET,6X30	2	2			
92153A	92153-1948	BOLT,SOCKET,6X12	2	2			
92154	92154-0477	BOLT,SOCKET,6X25	4	4			
92154A	92154-2650	BOLT,FLANGED,12X40	1	1			
92161	92161-0856	DAMPER	1	1			
92200	92200-0369	WASHER,12X34X9	1	1			

24. Ignition System

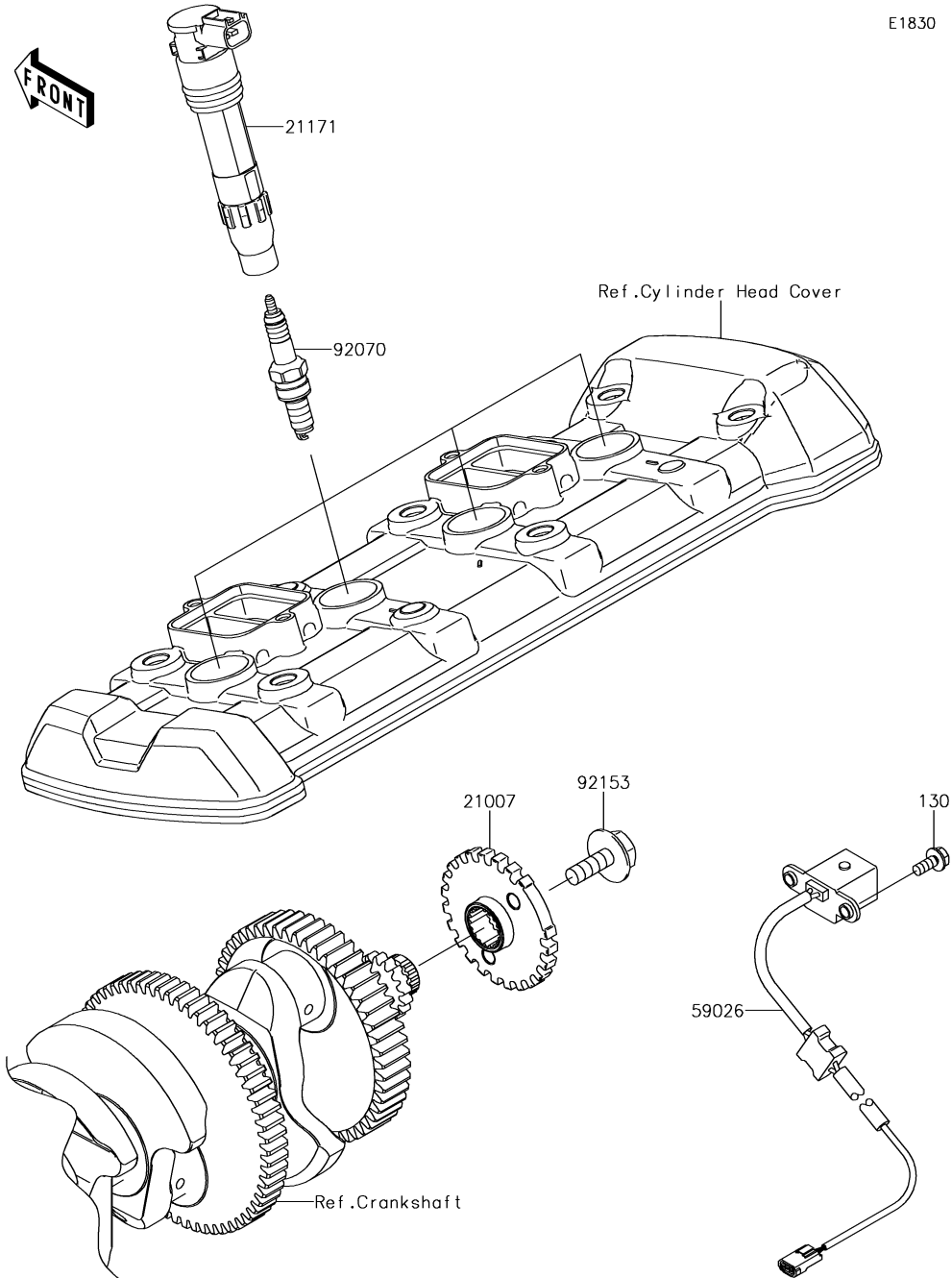

Ref. No.	Part No.	Description	Spec Code	Quantity			
				'17	'18		
				HHF	HJF		
21007	21007-0579	ROTOR		1	1		
21171	21171-0033	COIL-ASSY-IGNITION		4	4		
59026	59026-0043	COIL-PULSING		1	1		
92070	92070-0014	PLUG-SPARK,CR9EIA(NGK)		4	4		
92153	92153-0549	BOLT,FLANGED,8X23		1	1		
130	130BA0512	BOLT-FLANGED,5X12		2	2		

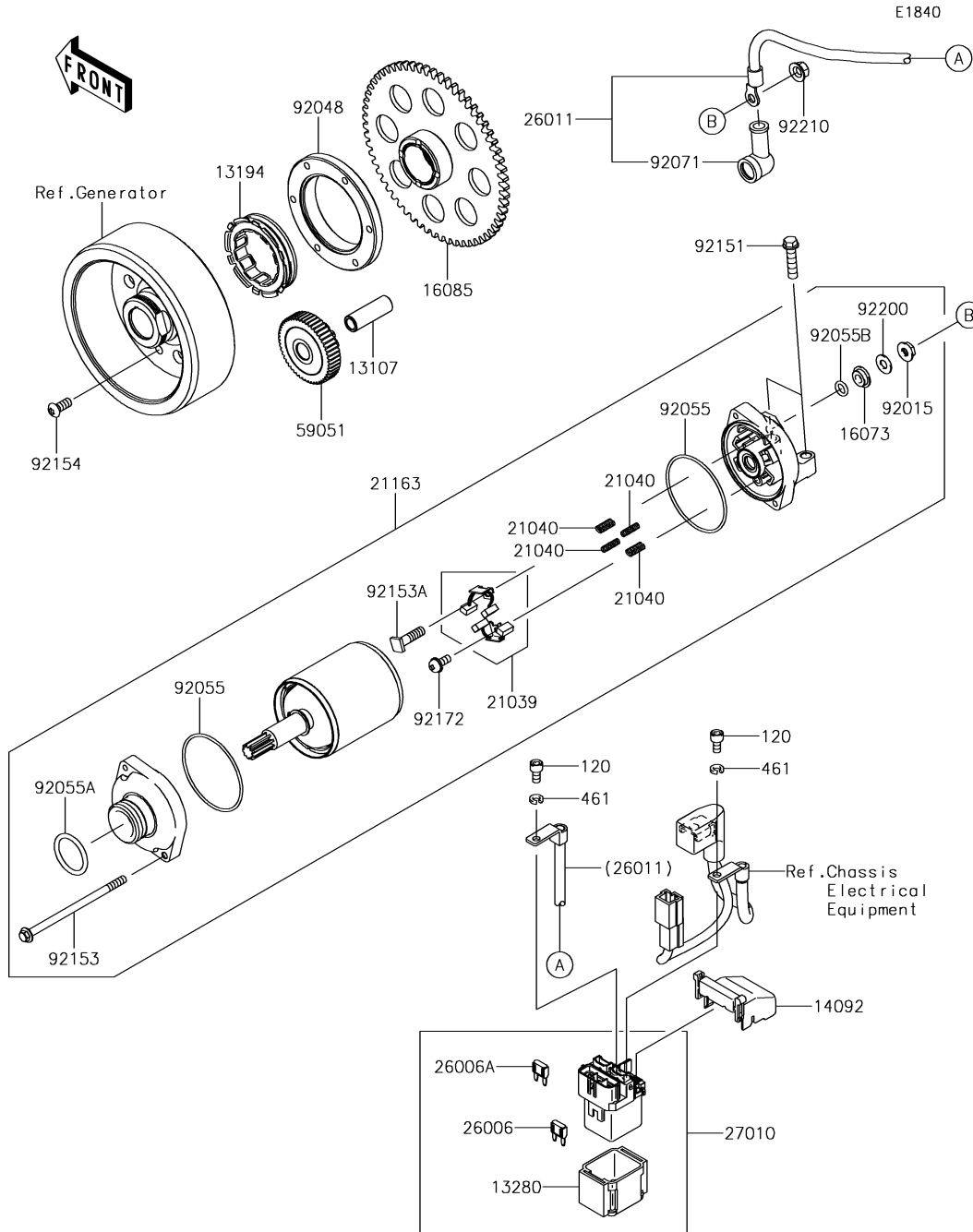

25. Starter Motor

Ref. No.	Part No.	Description	Spec Code	Quantity			
				'17	'18		
				HHF	HJF		
13107	13107-1377	SHAFT, IDLER GEAR		1	1		
13194	13194-1096	CLUTCH-ONEWAY		1	1		
13280	13280-0814	HOLDER, MAGNETIC SWITCH		1	1		
14092	14092-0109	COVER		1	1		
16073	16073-0053	INSULATOR		1	1		
16085	16085-0609	GEAR, CLUTCH ONEWAY		1	1		
21039	21039-0004	BRUSH, CARBON		1	1		
21040	21040-0003	SPRING-BRUSH		4	4		
21163	21163-0761	STARTER-ELECTRIC		1	1		
26006	26006-0001	FUSE, MINI BLADE, 15A, BLUE		1	1		
26006A	26006-1080	FUSE, MINI BLADE, 30A, GREEN		1	1		
26011	26011-0951	WIRE-LEAD		1	1		
27010	27010-0770	SWITCH		1	1		
59051	59051-0762	GEAR-SPUR, IDLER		1	1		
92015	92015-1476	NUT, STARTER MOTOR		1	1		
92048	92048-0018	RACE		1	1		
92055	92055-0136	RING-O		2	2		
92055A	92055-1276	RING-O		1	1		
92055B	92055-1370	RING-O, 4.5X2.0		1	1		
92071	92071-0024	GROMMET		1	1		
92151	92151-1930	BOLT, FLANGED-SMALL, 6X25		2	2		
92153	92153-1850	BOLT		2	2		
92153A	92153-1866	BOLT		1	1		
92154	92154-1225	BOLT, TORX, 6X14		6	6		
92172	92172-0334	SCREW		1	1		
92200	92200-0386	WASHER		1	1		
92210	92210-0188	NUT, 6MM		1	1		
120	120CB0510	BOLT-SOCKET, 5X10		2	2		
461	461DB0500	WASHER-SPRING, 5MM		2	2		

E3032

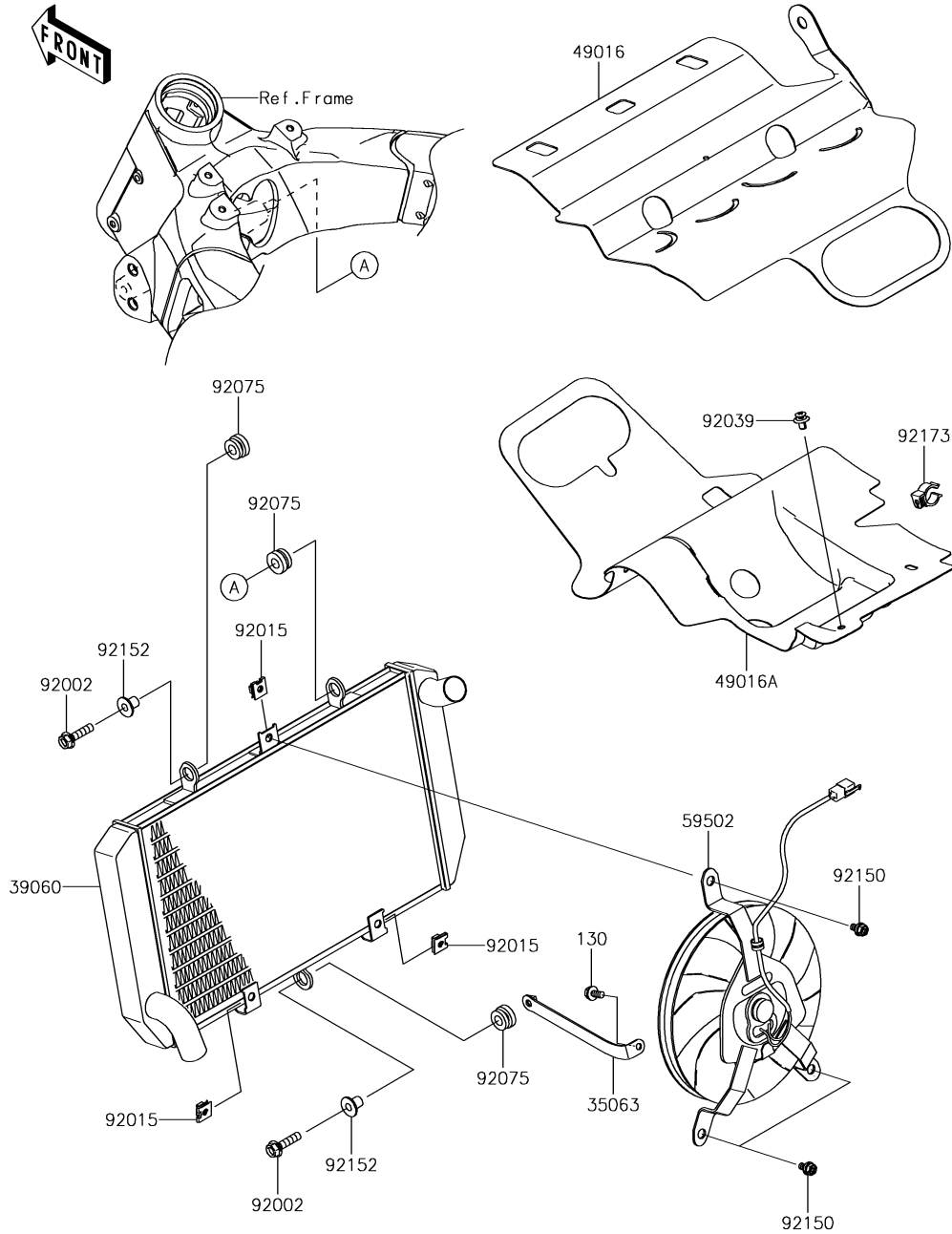

26. Radiator

Ref. No.	Part No.	Description	Spec Code	Quantity			
				'17	'18		
				HHF	HJF		
35063	35063-0761	STAY	1	1			
39060	39060-0072	RADIATOR	1	1			
49016	49016-0609	COVER-SEAL	1	1			
49016A	49016-0612	COVER-SEAL	1	1			
59502	59502-0612	FAN-ASSY	1	1			
92002	92002-1086	BOLT,FLANGED,6X25	2	2			
92015	92015-1487	NUT	3	3			
92039	92039-0730	RIVET	1	1			
92075	92075-1123	DAMPER,RUBBER	3	3			
92150	92150-1186	BOLT,6X12	3	3			
92152	92152-0667	COLLAR	2	2			
92173	92173-1240	CLAMP	1	1			
130	130CC0616	BOLT-FLANGED,6X16	1	1			

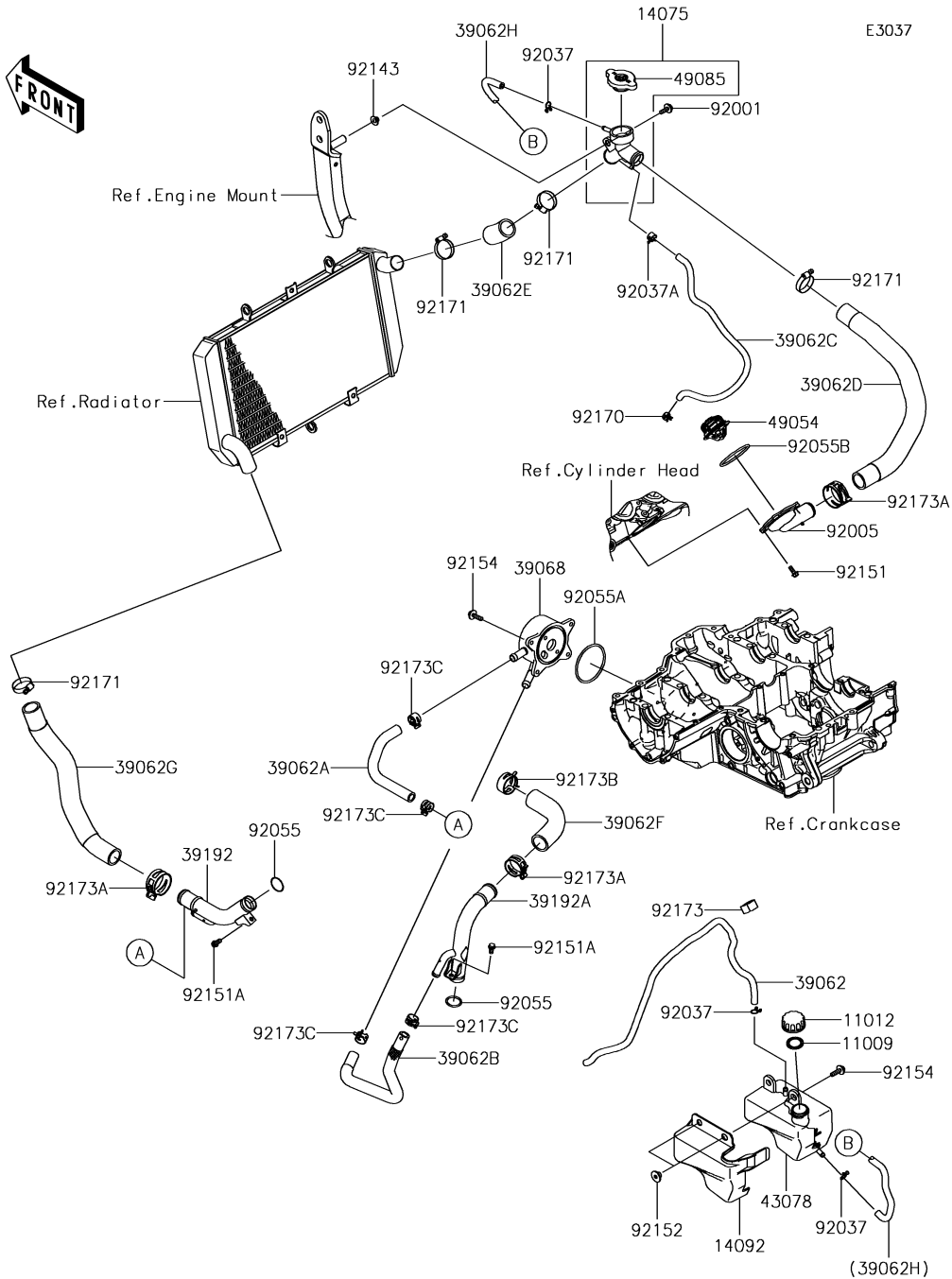

Ref. No.	Part No.	Description	Spec Code	Quantity			
				'17	'18		
				HHF	HJF		
11009	11009-1145	GASKET,RESERVOIR TANK CAP		1	1		
11012	11012-1084	CAP		1	1		
14075	14075-0028	CAP-ASSY		1	1		
14092	14092-1098	COVER,RESERVOIR		1	1		
39062	39062-0296	HOSE-COOLING,OVERFLOW		1	1		
39062A	39062-0308	HOSE-COOLING,PIPE-OIL COOLER		1	1		
39062B	39062-0309	HOSE-COOLING,PIPE-OIL COOLER		1	1		
39062C	39062-0310	HOSE-COOLING,AIR BLEED		1	1		
39062D	39062-0313	HOSE-COOLING,CAP-THERMO		1	1		
39062E	39062-0727	HOSE-COOLING,CAP-RAD.		1	1		
39062F	39062-0757	HOSE-COOLING,PIPE-CYLINDER		1	1		
39062G	39062-0766	HOSE-COOLING,RAD.-PIPE		1	1		
39062H	39062-1873	HOSE-COOLING		1	1		
39068	39068-0704	COOLER-ASSY-OIL		1	1		
39192	39192-0619	PIPE-WATER,RADIATOR-WATER PUMP		1	1		
39192A	39192-0620	PIPE-WATER,WATER PUMP-CYLINDER		1	1		
43078	43078-0566	RESERVOIR		1	1		
49054	49054-0004	THERMOSTAT		1	1		
49085	49085-1066	CAP-ASSY-PRESSURE		1	1		
92001	92001-1342	BOLT,6X18		1	1		
92005	92005-0842	FITTING,THERMO CAP		1	1		
92037	92037-147	CLAMP,TUBE		3	3		
92037A	92037-1505	CLAMP,TUBE		1	1		
92055	92055-0114	RING-O,20.8X2.4		2	2		
92055A	92055-0739	RING-O,63.3MM		1	1		
92055B	92055-0831	RING-O,53.5X2.6		1	1		
92143	92143-1057	COLLAR		1	1		
92151	92151-1764	BOLT,5X14		4	4		
92151A	92151-1997	BOLT,6X12		2	2		
92152	92152-1740	COLLAR		2	2		
92154	92154-0403	BOLT,FLANGED,6X22		6	6		
92170	92170-1493	CLAMP		1	1		
92171	92171-0179	CLAMP		4	4		
92173	92173-0127	CLAMP,CLIP		1	1		
92173A	92173-1360	CLAMP,34MM		3	3		
92173B	92173-1432	CLAMP,35.5MM		1	1		
92173C	92173-1552	CLAMP		4	4		

'17-'18 ZR1000 HHF/HJF

F2120

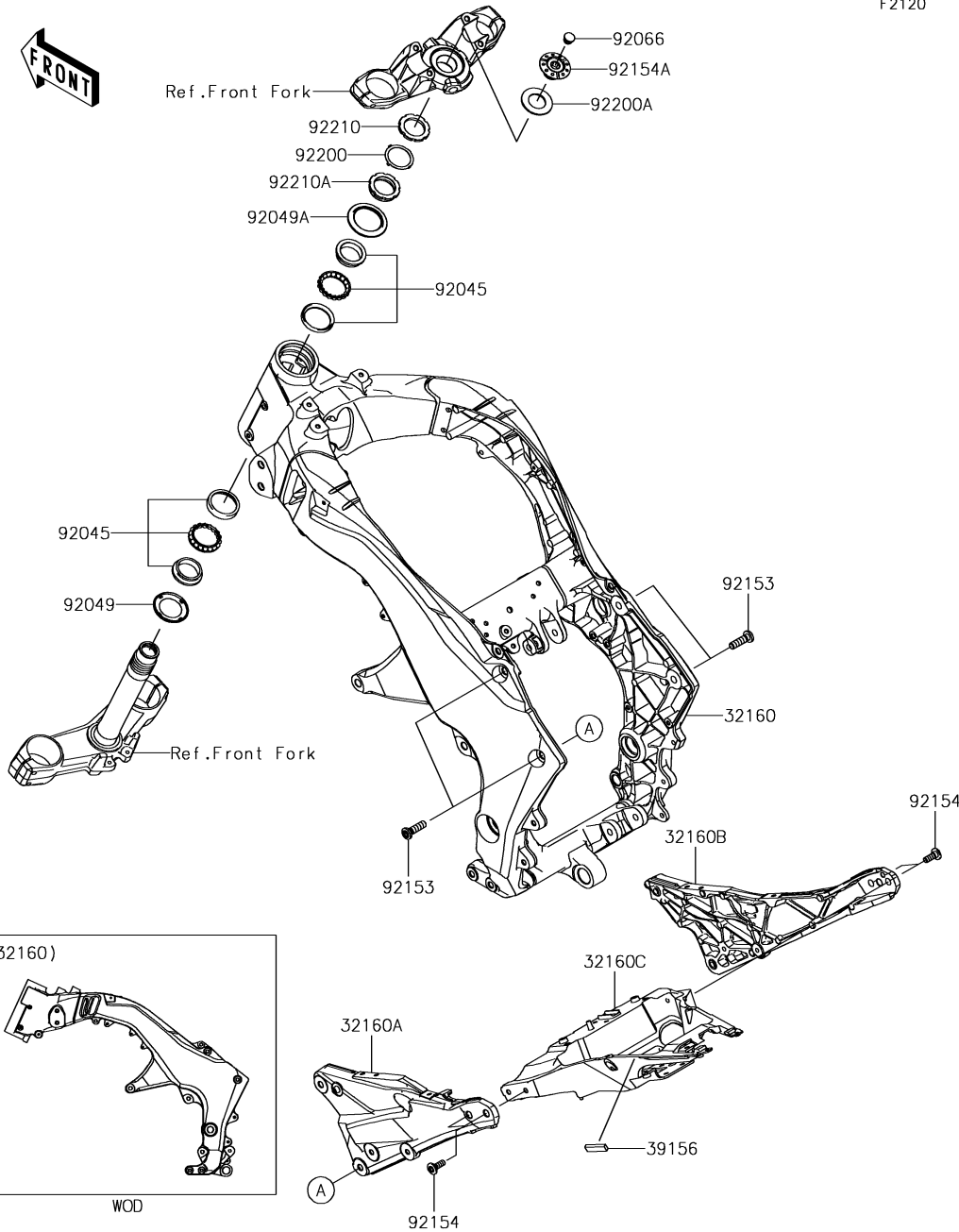

28. Frame

Ref. No.	Part No.	Description	Spec Code	Quantity			
				'17	'18		
				HHF	HJF		
32160	32160-0694-18R	FRAME-COMP,MAIN,F.S.BLACK		1	1		
32160A	32160-0695-18R	FRAME-COMP,RR,LH,F.S.BLACK		1	1		
32160B	32160-0696-18R	FRAME-COMP,RR,RH,F.S.BLACK		1	1		
32160C	32160-0697	FRAME-COMP,RR		1	1		
39156	39156-1811	PAD,10X34X5		1	1		
92045	92045-1384	BEARING-BALL,SF07A17PX1V1		2	2		
92049	92049-0022	SEAL-OIL,DS35X55X4		1	1		
92049A	92049-0742	SEAL-OIL,43X55.5X8.6		1	1		
92066	92066-0071	PLUG		1	1		
92153	92153-1442	BOLT,SOCKET,10X35		4	4		
92154	92154-0379	BOLT,SOCKET,8X23		4	4		
92154A	92154-2624	BOLT,TOP,26X18		1	1		
92200	92200-0036	WASHER		1	1		
92200A	92200-0892	WASHER,27X48X2.3		1	1		
92210	92210-0095	NUT,35MM		1	1		
92210A	92210-0823	NUT,35MM		1	1		

29. Engine Mount

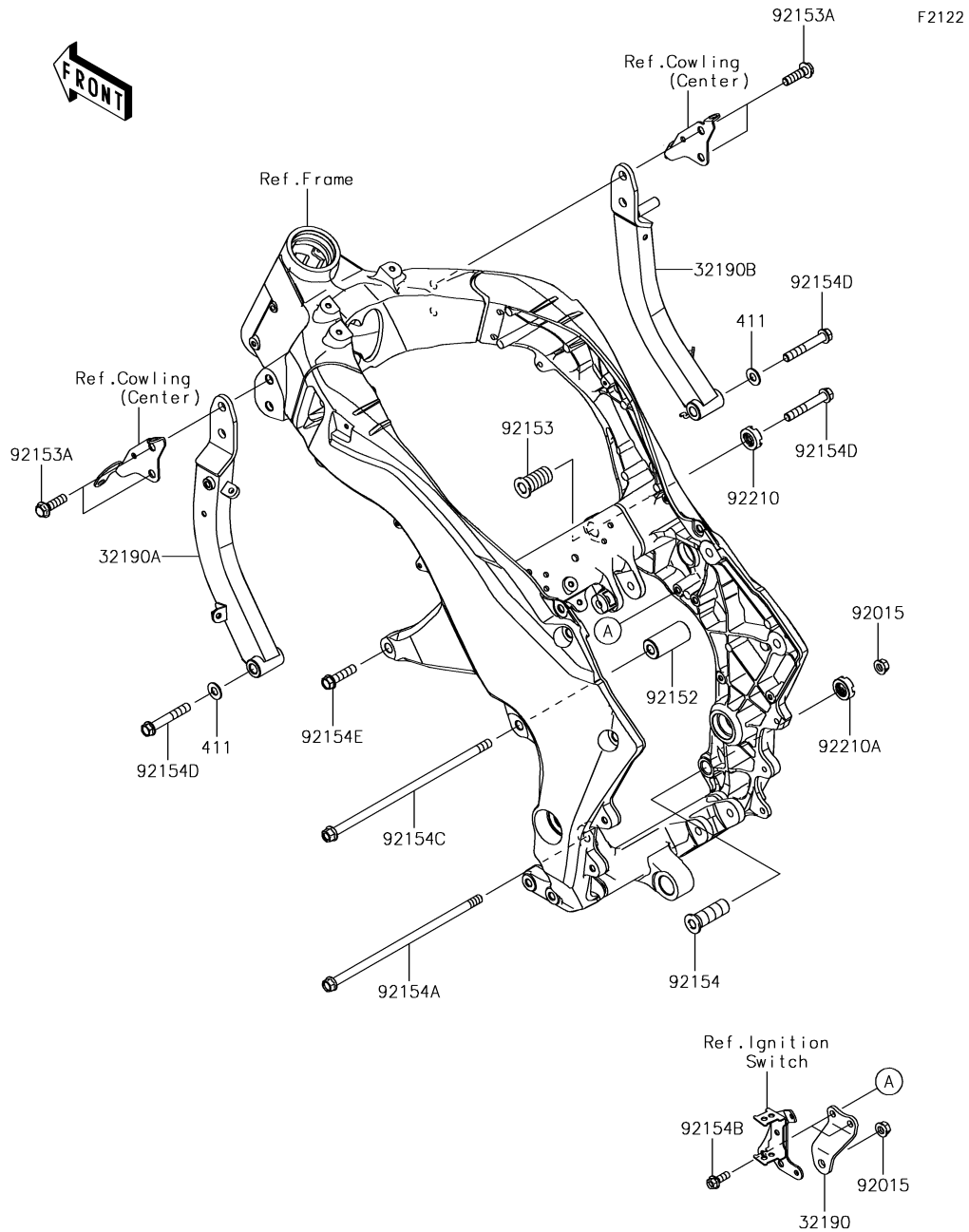

Ref. No.	Part No.	Description	Spec Code	Quantity			
				'17	'18		
				HHF	HJF		
32190	32190-0458-18R	BRACKET-ENGINE,CR CASE UPP,BLK	1	1			
32190A	32190-0650-18R	BRACKET-ENGINE,LH,F.S.BLACK	1	1			
32190B	32190-0651-18R	BRACKET-ENGINE,RH,F.S.BLACK	1	1			
92015	92015-1180	NUT,FLANGED,10MM	2	2			
92152	92152-0853	COLLAR,11X26X56.5	1	1			
92153	92153-0488	BOLT,SOCKET,20X43	1	1			
92153A	92153-0802	BOLT,FLANGED,10X35	4	4			
92154	92154-0267	BOLT,ENGINE MOUNT,18X53.5	1	1			
92154A	92154-0827	BOLT,FLANGED,10X255	1	1			
92154B	92154-1852	BOLT,FLANGED,8X20	2	2			
92154C	92154-2309	BOLT,FLANGED,10X270	1	1			
92154D	92154-2310	BOLT,FLANGED,10X65	3	3			
92154E	92154-2311	BOLT,FLANGED,10X40	1	1			
92210	92210-0591	NUT,20MM	1	1			
92210A	92210-1517	NUT,CASTLE,18MM	1	1			
411	411AB1000	WASHER-PLAIN,10MM,BLACK	2	2			

'17-'18 ZR1000 HHF/HJF

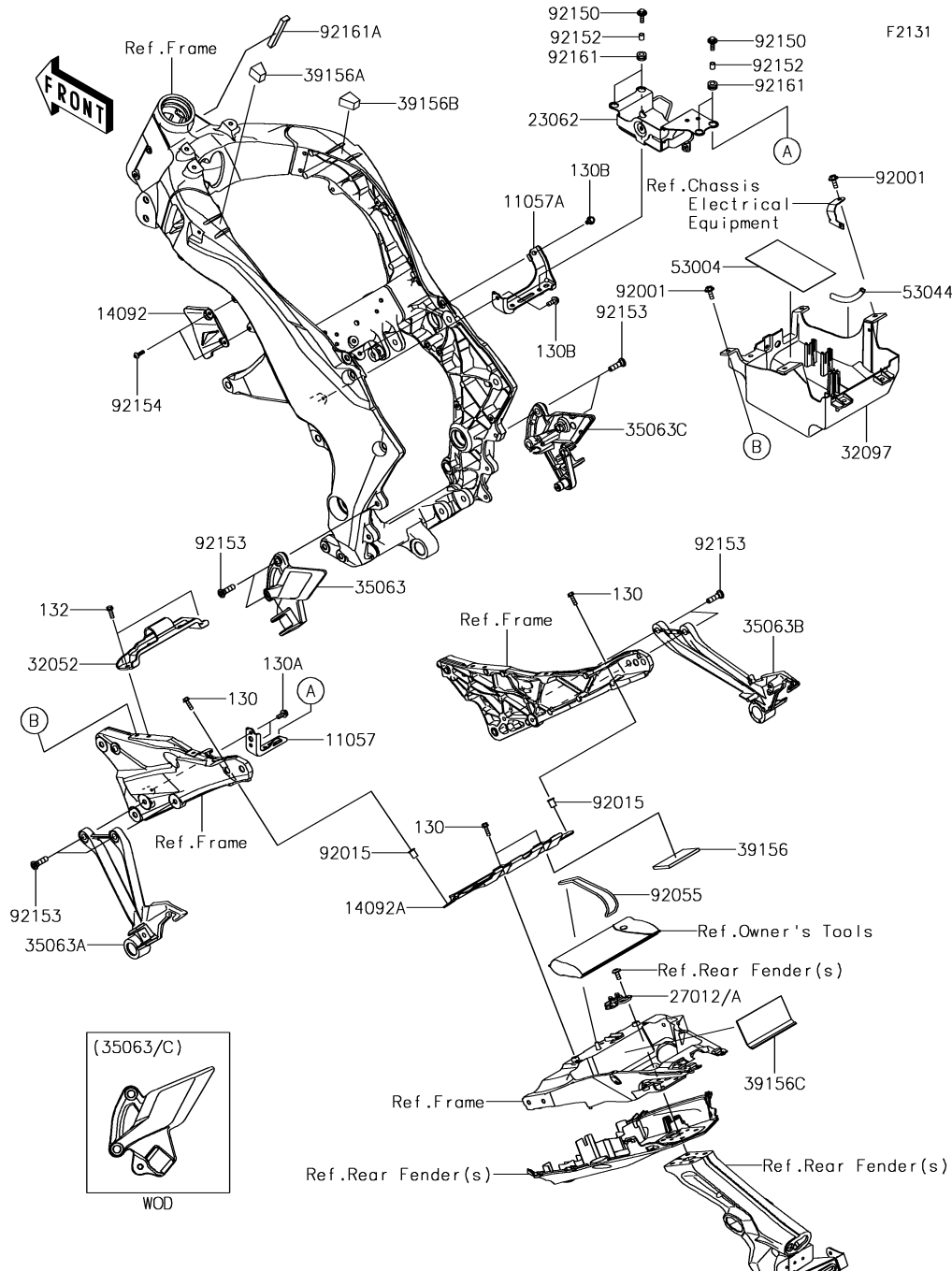

30. Frame Fittings

Ref. No.	Part No.	Description	Spec Code	Quantity			
				'17	'18		
				HHF	HJF		
11057	11057-0429	BRACKET,ABS UNIT	1	1			
11057A	11057-0430	BRACKET,REGULATOR	1	1			
14092	14092-0016	COVER,THROBO	1	1			
14092A	14092-1135	COVER,ECU	1	1			
23062	23062-0816	BRACKET-COMP,ABS	1	1			
27012	27012-0779	HOOK,TOOL BAND	1				
27012A	27012-0843	HOOK		1			
32052	32052-0155	BRACKET-TANK	1	1			
32097	32097-0042	CASE-BATTERY	1	1			
35063	35063-0657-18R	STAY,FR,LH,F.S.BLACK	1	1			
35063A	35063-0659-18R	STAY,RR,LH,F.S.BLACK	1	1			
35063B	35063-0660-18R	STAY,RR,RH,F.S.BLACK	1	1			
35063C	35063-0920-18R	STAY,FR,RH,F.S.BLACK	1	1			
39156	39156-0866	PAD,45X75X5	1	1			
39156A	39156-1733	PAD,FR FRM,LH	1	1			
39156B	39156-1734	PAD,FR FRM,RH	1	1			
39156C	39156-1778	PAD,RR FRM	1	1			
53004	53004-0560	MAT,BATTERY	1	1			
53044	53044-0018	TRIM	1	1			
92001	92001-1342	BOLT,6X18	4	4			
92015	92015-1757	NUT,WELL,5MM	2	2			
92055	92055-0778	RING-O,66.6X3.5	1	1			
92150	92150-1339	BOLT,FLANGED,6X20	4	4			
92152	92152-1782	COLLAR,6.1X8.1X9	4	4			
92153	92153-1624	BOLT,SOCKET,8X30	8	8			
92154	92154-0209	BOLT,SOCKET,5X16	2	2			
92161	92161-1584	DAMPER,8.2X16X8.3	4	4			
92161A	92161-1947	DAMPER,80X15X8	1	1			
130	130BA0518	BOLT-FLANGED,5X18	4	4			
130A	130BA0614	BOLT-FLANGED,6X14	2	2			
130B	130BA0616	BOLT-FLANGED,6X16	2	2			
132	132BA0616	BOLT-FLANGED-SMALL,6X16	2	2			

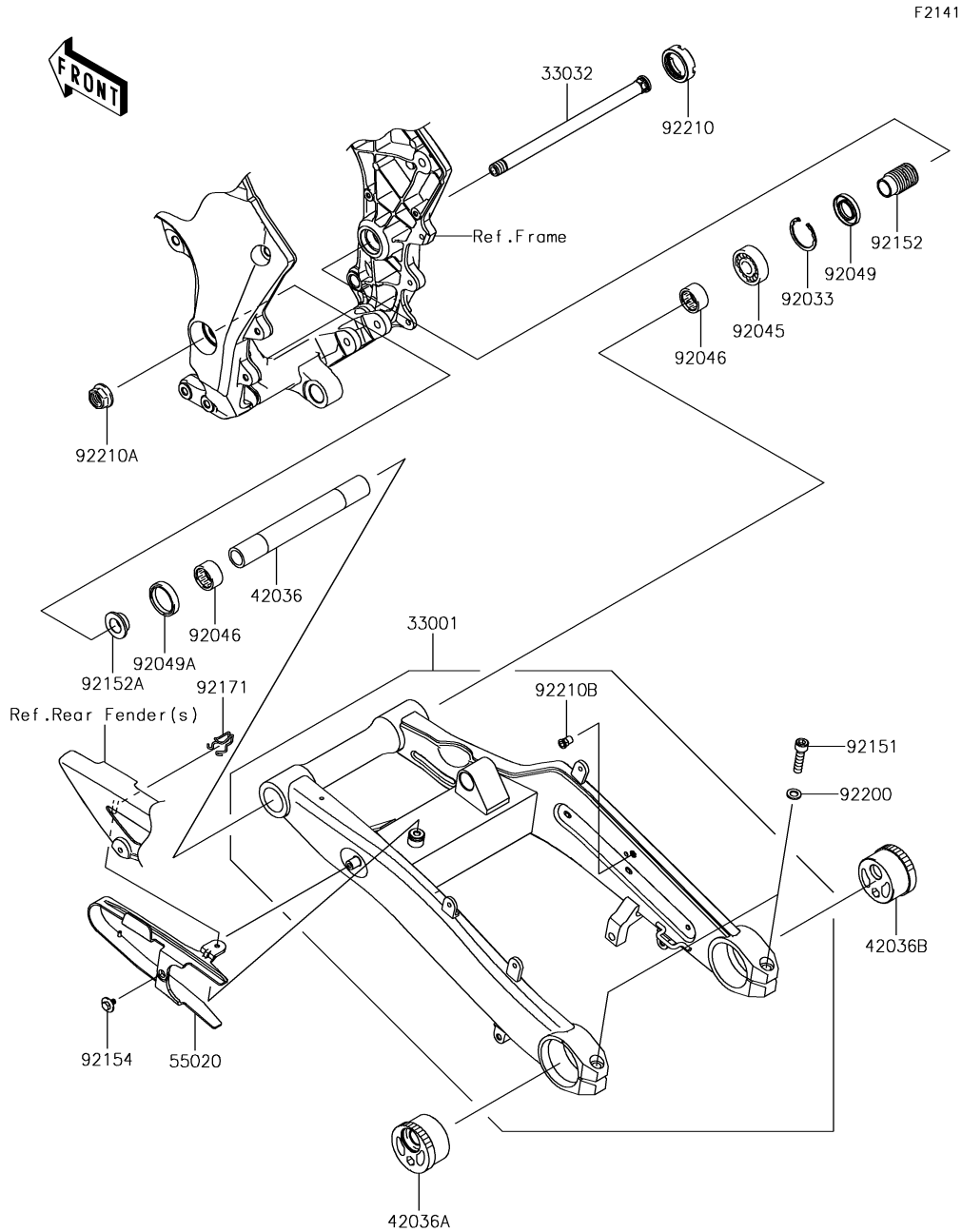

31. Swingarm

Ref. No.	Part No.	Description	Spec Code	Quantity			
				'17	'18		
				HHF	HJF		
33001	33001-0671-18R	ARM-COMP-SWING,F.S.BLACK	1	1			
33032	33032-0044	SHAFT-SWING ARM	1	1			
42036	42036-0069	SLEEVE,20.1X28X226	1	1			
42036A	42036-1153-KX	SLEEVE,REAR AXLE,LH,SILVER	1	1			
42036B	42036-1265-KX	SLEEVE,REAR AXLE,RH,SILVER	1	1			
55020	55020-0903	GUARD,CHAIN	1	1			
92033	92033-1041	RING-SNAP,42MM	1	1			
92045	92045-0017	BEARING-BALL,6004UL11	1	1			
92046	92046-0008	BEARING-NEEDLE,7E-HVS 28X34X17	2	2			
92049	92049-1314	SEAL-OIL,MHSA25X42X6	1	1			
92049A	92049-1352	SEAL-OIL,MHSA25X34X7	1	1			
92151	92151-1899	BOLT,SOCKET,10X40	2	2			
92152	92152-0154	COLLAR,SWING ARM,L=47	1	1			
92152A	92152-1234	COLLAR,SWING ARM,L=12.5	1	1			
92154	92154-2324	BOLT-UPSET-WP,6X12	1	1			
92171	92171-0907	CLAMP	1	1			
92200	92200-0531	WASHER,10.5X18X2.0	2	2			
92210	92210-0134	NUT,30MM	1	1			
92210A	92210-0320	NUT,FLANGED,20MM	1	1			
92210B	92210-1397	NUT,POP,6MM,L=15	1	1			

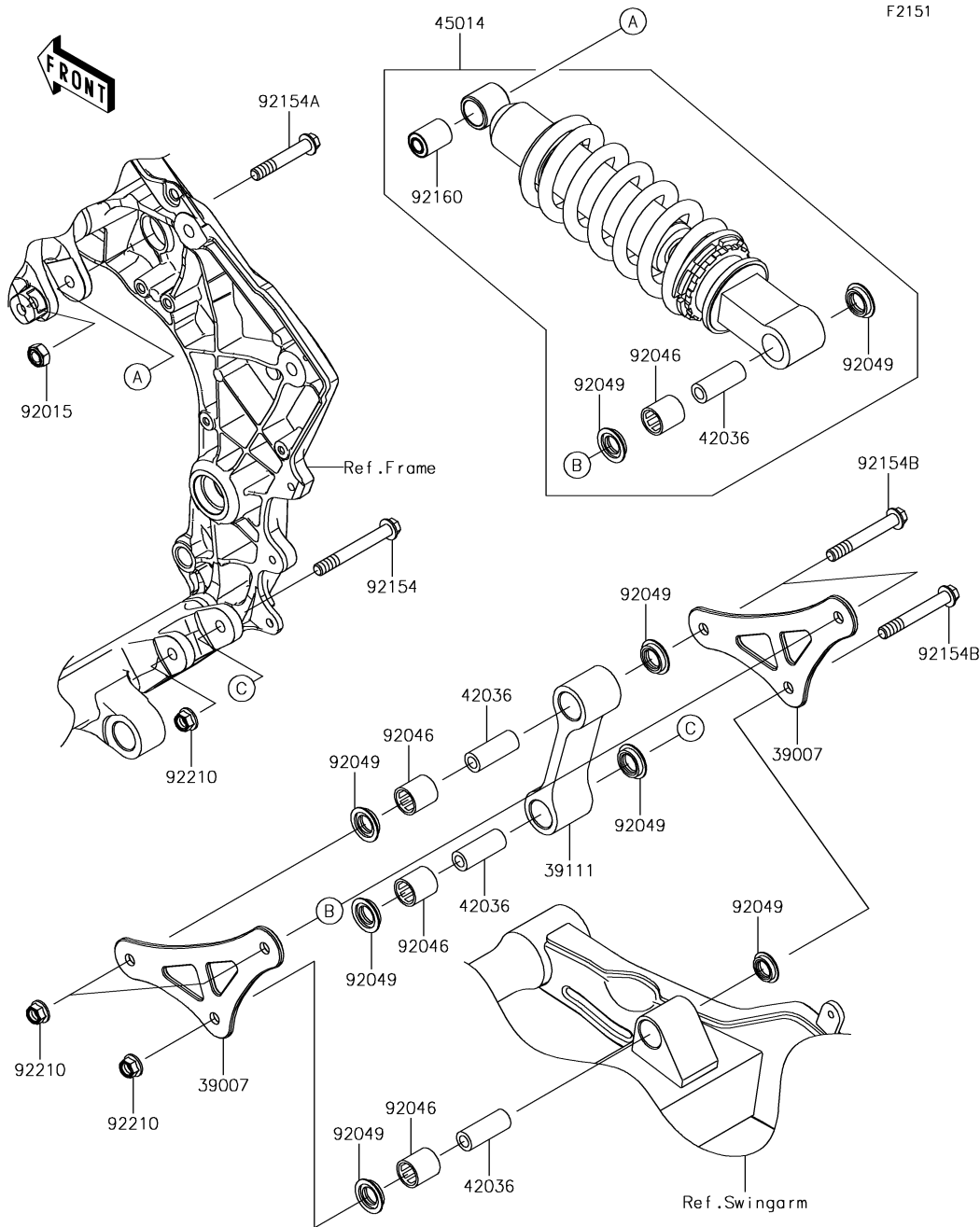

Ref. No.	Part No.	Description	Spec Code	Quantity			
				'17	'18		
				HHF	HJF		
39007	39007-0405-18R	ARM-SUSP,F.S.BLACK		2	2		
39111	39111-0345	ROD-TIE,SUSPENSION		1	1		
42036	42036-1342	SLEEVE,10.1X17X44.5		4	4		
45014	45014-0573-10	SHOCKABSORBER,BLACK		1	1		
92015	92015-1189	NUT,LOCK,10MM,BLACK		1	1		
92046	92046-1273	BEARING-NEEDLE,SFYZM172425		4	4		
92049	92049-1223	SEAL-OIL,MHA17245.7F		8	8		
92154	92154-0262	BOLT,FLANGED,10X77		1	1		
92154A	92154-0263	BOLT,FLANGED,10X60		1	1		
92154B	92154-0264	BOLT,FLANGED,10X67		3	3		
92160	92160-1496	DAMPER,SHOCKABSORBER		1	1		
92210	92210-1139	NUT,LOCK,FLANGED,10MM		4	4		

33. Footrests

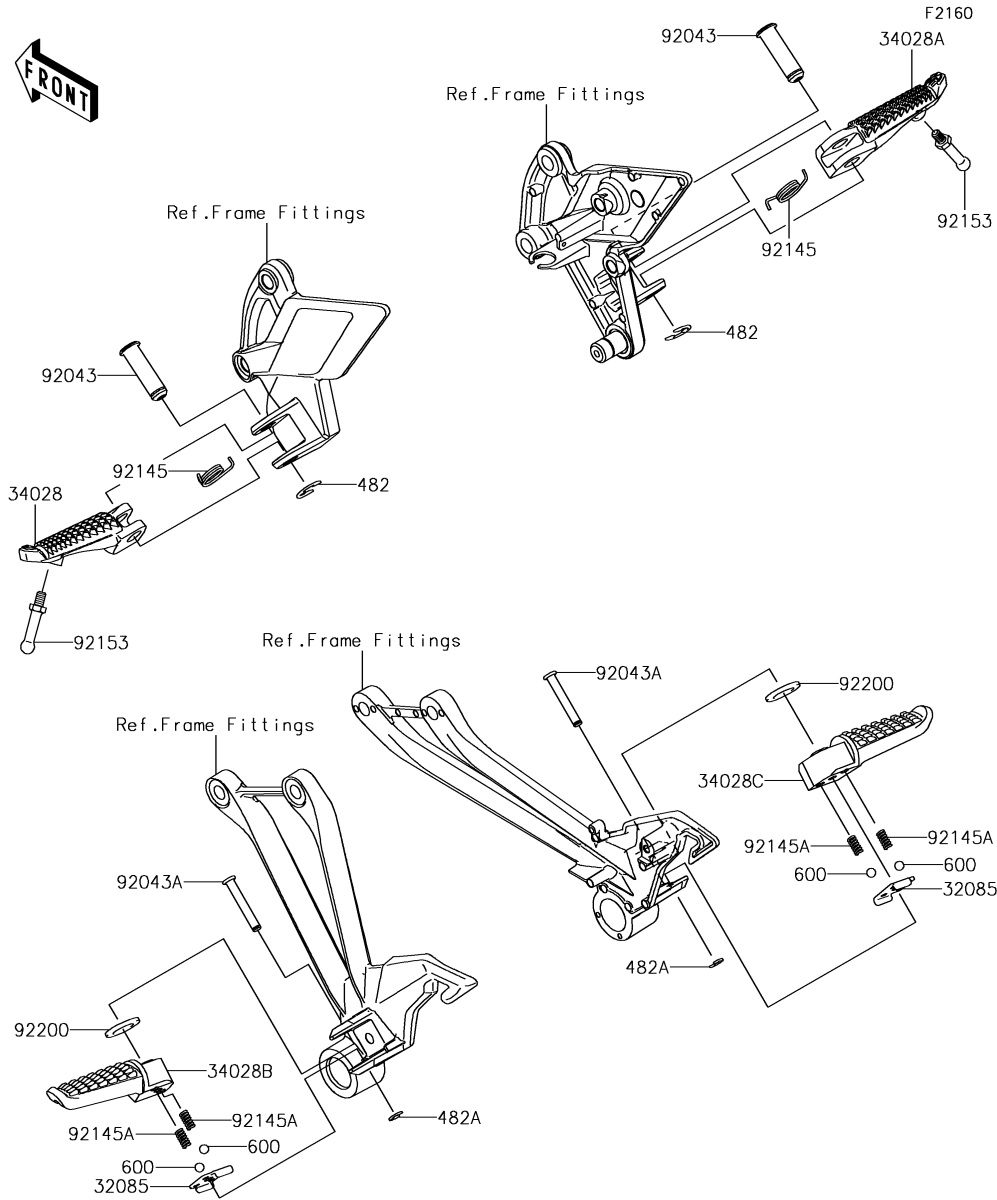

Ref. No.	Part No.	Description	Spec Code	Quantity			
				'17	'18		
				HHF	HJF		
32085	32085-0047	STOPPER,REAR STEP	2	2			
34028	34028-0092	STEP,FR,LH	1	1			
34028A	34028-0093	STEP,FR,RH	1	1			
34028B	34028-0094	STEP,RR,LH	1	1			
34028C	34028-0095	STEP,RR,RH	1	1			
92043	92043-1594	PIN,12X42.5	2	2			
92043A	92043-1595	PIN,6X40	2	2			
92145	92145-0603	SPRING,STEP RETURN	2	2			
92145A	92145-1319	SPRING	4	4			
92153	92153-1938	BOLT,BANK SENSOR	2	2			
92200	92200-0043	WASHER,16X26X2.3	2	2			
482	482EA0100	CIRCLIP-TYPE-E,10MM	2	2			
482A	482EA5000	CIRCLIP-TYPE-E	2	2			
600	600A0800	BALL-STEEL,1/4	4	4			

F2171

34. Front Fender(s)

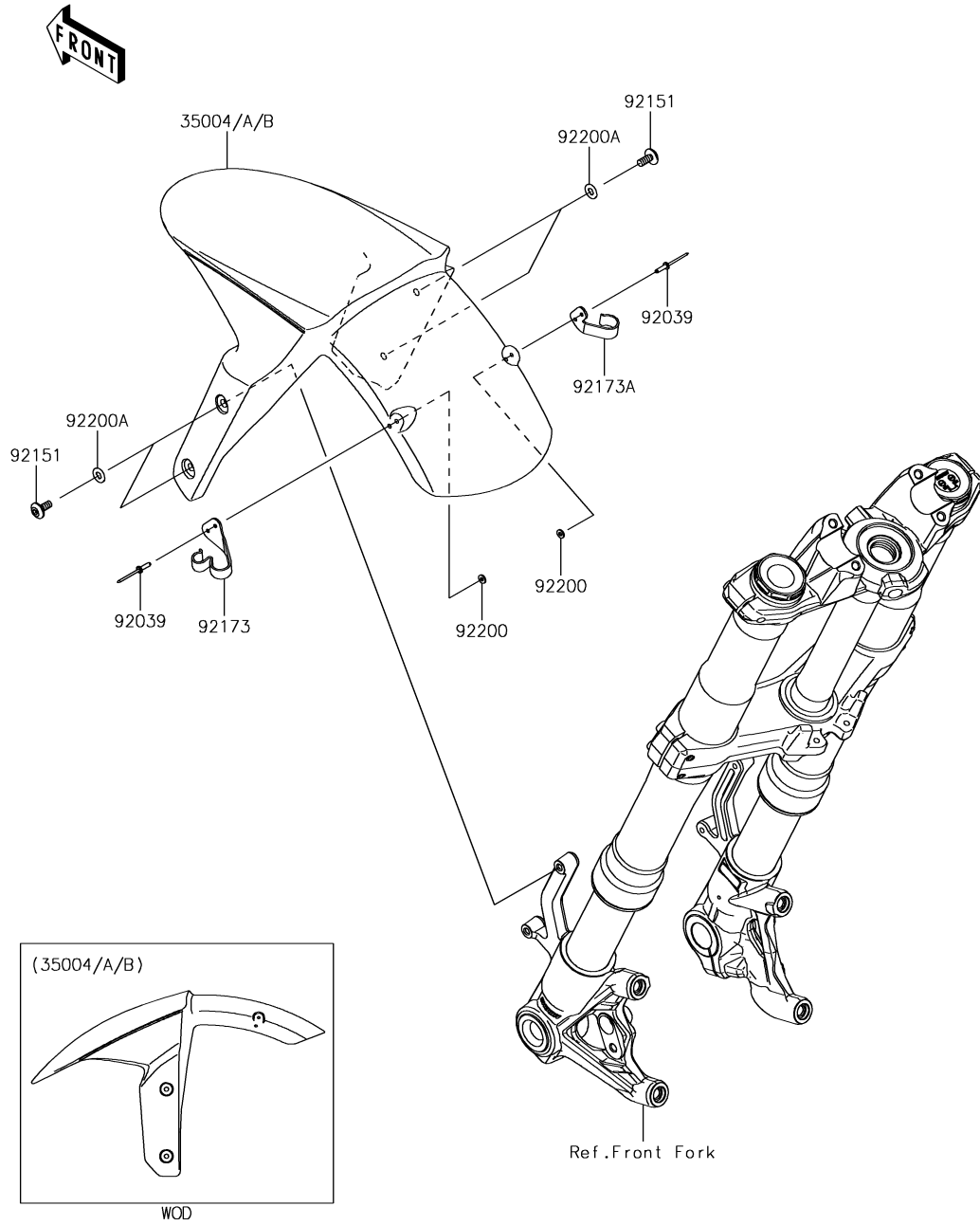

Ref. No.	Part No.	Description	Spec Code	Quantity			
				'17	'18		
				HHF	HJF		
35004	35004-0310-45L	FENDER-FRONT,F.EBONY		1	1		
35004A	35004-0310-660	FENDER-FRONT,M.S.BLACK			1		
35004B	35004-0310-739	FENDER-FRONT,M.F.S.BLACK		1			
92039	92039-0705	RIVET		4	4		
92151	92151-1654	BOLT,SOCKET,6X14		4	4		
92173	92173-1153	CLAMP,FR FENDER,LH		1	1		
92173A	92173-1154	CLAMP,FR FENDER,RH		1	1		
92200	92200-1251	WASHER,3.5X8X1		4	4		
92200A	92200-1388	WASHER,6.5X14X1		4	4		

'17-'18 ZR1000 HHF/HJF

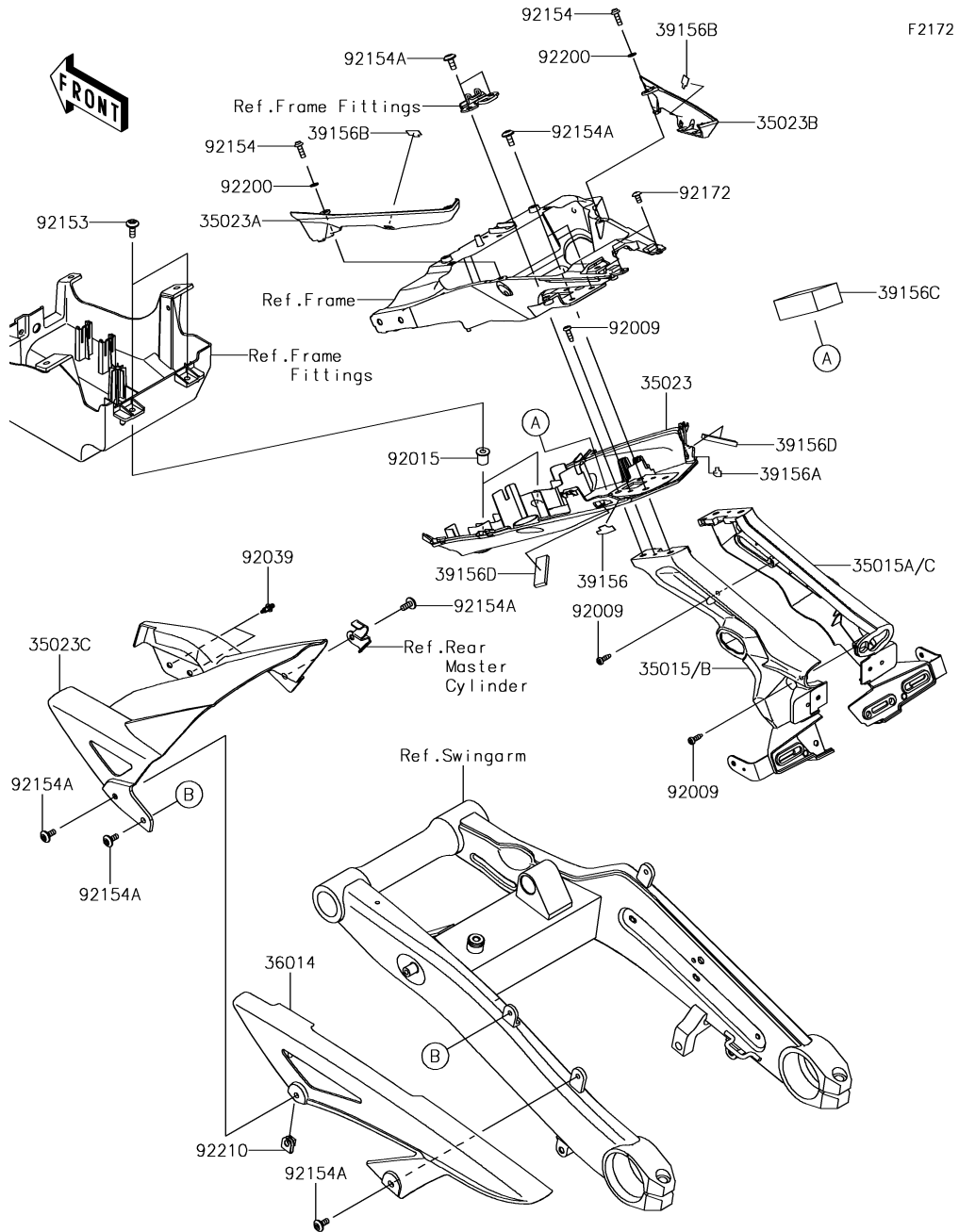

35. Rear Fender(s)

Ref. No.	Part No.	Description	Spec Code	Quantity			
				'17	'18		
				HHF	HJF		
35015	35015-0036	FLAP-COMP,LH		1			
35015A	35015-0037	FLAP-COMP,RH		1			
35015B	35015-0040	FLAP-COMP,LH			1		
35015C	35015-0041	FLAP-COMP,RH			1		
35023	35023-0378	FENDER-REAR,CNT	1	1			
35023A	35023-0379	FENDER-REAR,LH	1	1			
35023B	35023-0380	FENDER-REAR,RH	1	1			
35023C	35023-0424	FENDER-REAR,INNER	1	1			
36014	36014-0029	CASE-CHAIN	1	1			
39156	39156-1786	PAD,RR FENDER,RR,LH	1	1			
39156A	39156-1787	PAD,RR FENDER,RR,RH	1	1			
39156B	39156-1788	PAD,RR FENDER LH&RH	2	2			
39156C	39156-1808	PAD,40X80X25	1	1			
39156D	39156-1812	PAD,RR FENDER,42X15X5	2	2			
92009	92009-1984	SCREW,TAPPING,5X16	4	4			
92015	92015-1700	NUT	2	2			
92039	92039-0060	RIVET	2	2			
92153	92153-0816	BOLT,6X18	2	2			
92154	92154-0209	BOLT,SOCKET,5X16	2	2			
92154A	92154-0745	BOLT,SOCKET,6X14	8	8			
92172	92172-0262	SCREW,TAPPING,5X10	2	2			
92200	92200-1820	WASHER,5.2X10X1.0	2	2			
92210	92210-0277	NUT,6MM	1	1			

F2190

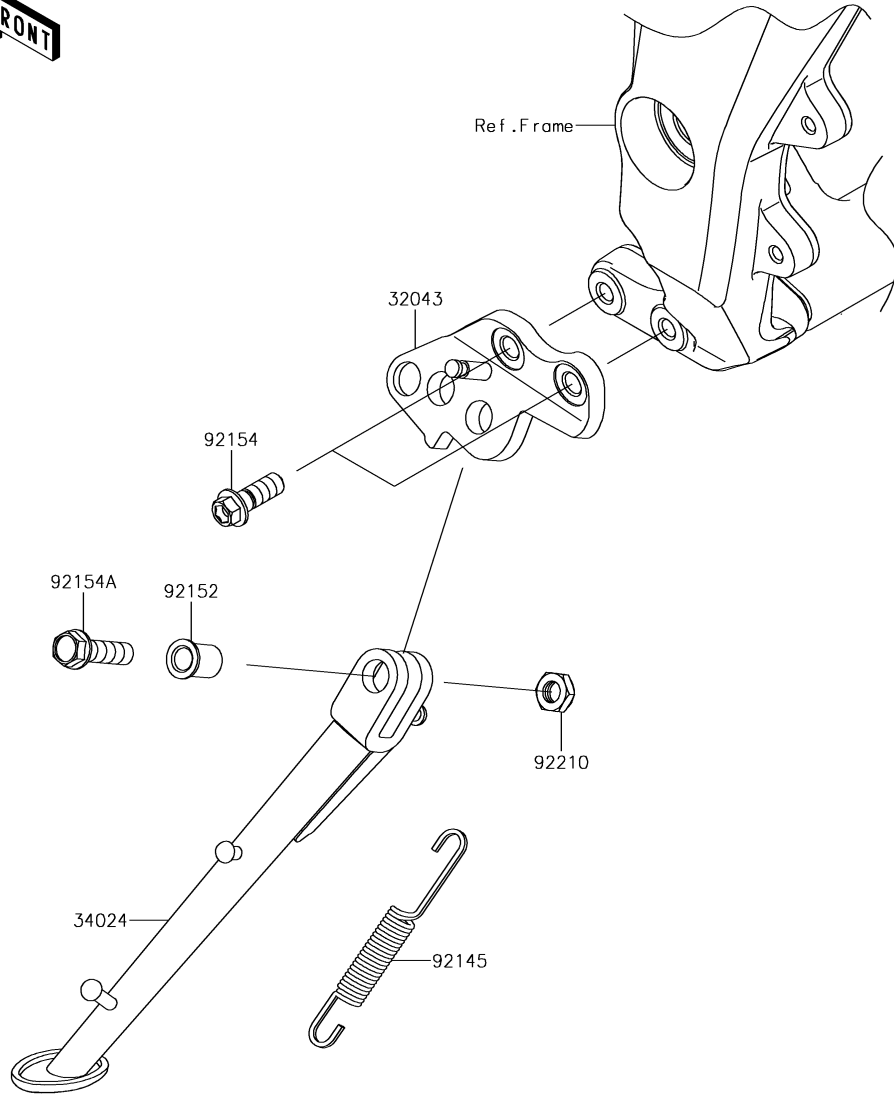

36. Stand(s)

Ref. No.	Part No.	Description	Spec Code	Quantity			
				'17	'18		
				HHF	HJF		
32043	32043-0583-18R	BRACKET-STAND,F.S.BLACK		1	1		
34024	34024-0118-18R	STAND-SIDE,F.S.BLACK		1	1		
92145	92145-0562	SPRING,SIDE STAND		1	1		
92152	92152-1828	COLLAR,10.2X15X20.1		1	1		
92154	92154-1963	BOLT,FLANGED,10X28		2	2		
92154A	92154-2330	BOLT,FLANGED,10X37		1	1		
92210	92210-0784	NUT,LOCK,10MM		1	1		

F2210

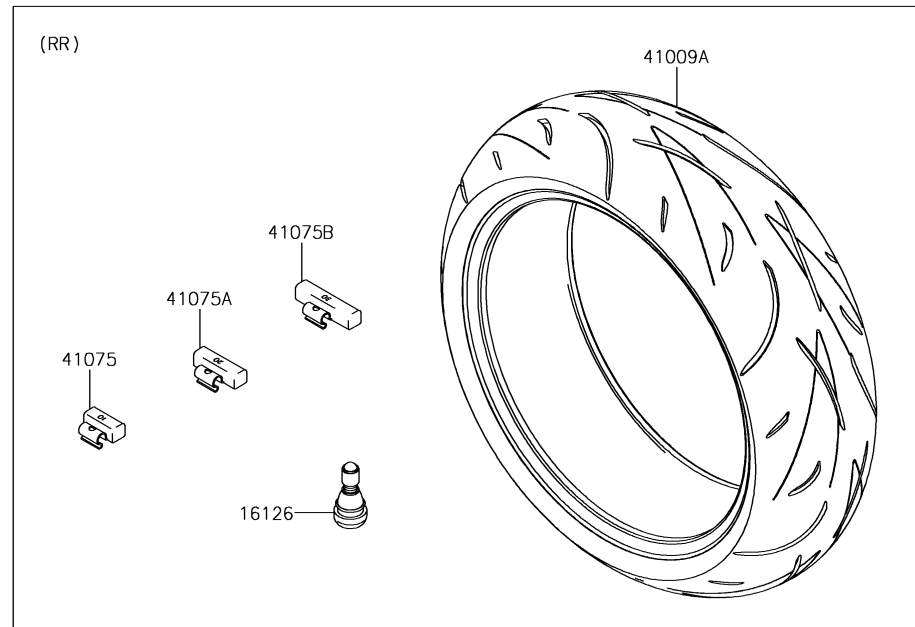
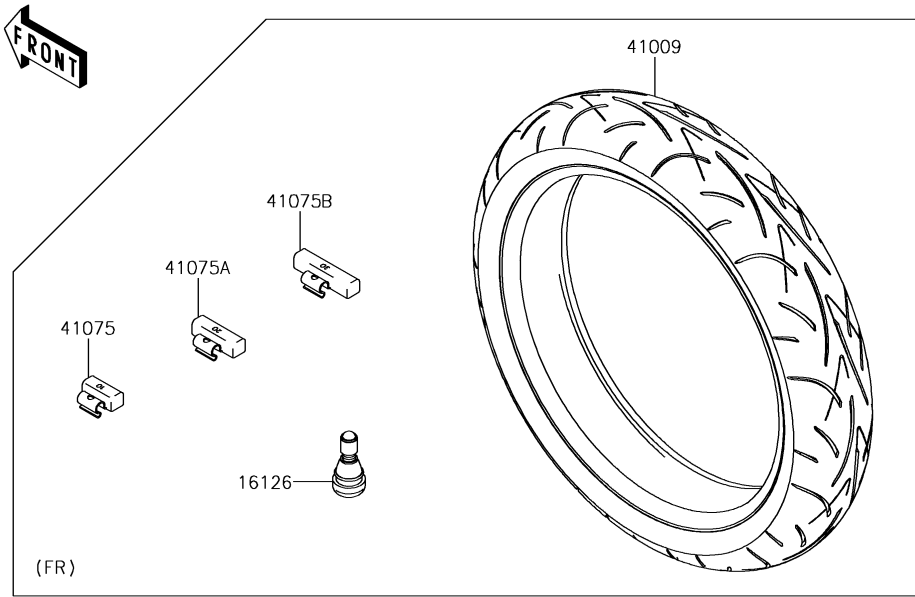

37. Tires

Ref. No.	Part No.	Description	Spec Code	Quantity			
				'17	'18		
				HHF	HJF		
16126	16126-1140	VALVE,TIRE		2	2		
41009	41009-0623	TIRE,FR,120/70ZR17(58W),D214F		1	1		
41009A	41009-0624	TIRE,RR,190/50ZR17(73W),D214		1	1		
41075	41075-0007	BALANCER-WHEEL,10G,SILVER		AR	AR		
41075A	41075-0008	BALANCER-WHEEL,20G,SILVER		AR	AR		
41075B	41075-0009	BALANCER-WHEEL,30G,SILVER		AR	AR		

F2230



(41073/A)

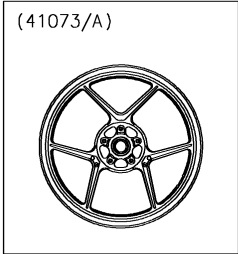

WOD

41073/A

41068

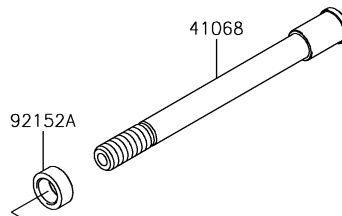

92152A

92045



92049

92045

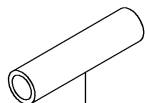

92152

92049



92152A

Ref. Tires



38. Front Hub

Ref. No.	Part No.	Description	Spec Code	Quantity			
				'17	'18		
				HHF	HJF		
41068	41068-0616	AXLE,FR,20X209		1	1		
41073	41073-0708-18F	WHEEL-ASSY,FR,G.BLACK		1			
41073A	41073-0724-18F	WHEEL-ASSY,FR,G.BLACK			1		
92045	92045-0820	BEARING-BALL,20X42X12		2	2		
92049	92049-1057	SEAL-OIL,BJN30427-C3		2	2		
92152	92152-0087	COLLAR,FR HUB,L=115		1	1		
92152A	92152-1739	COLLAR,20X30X13		2	2		

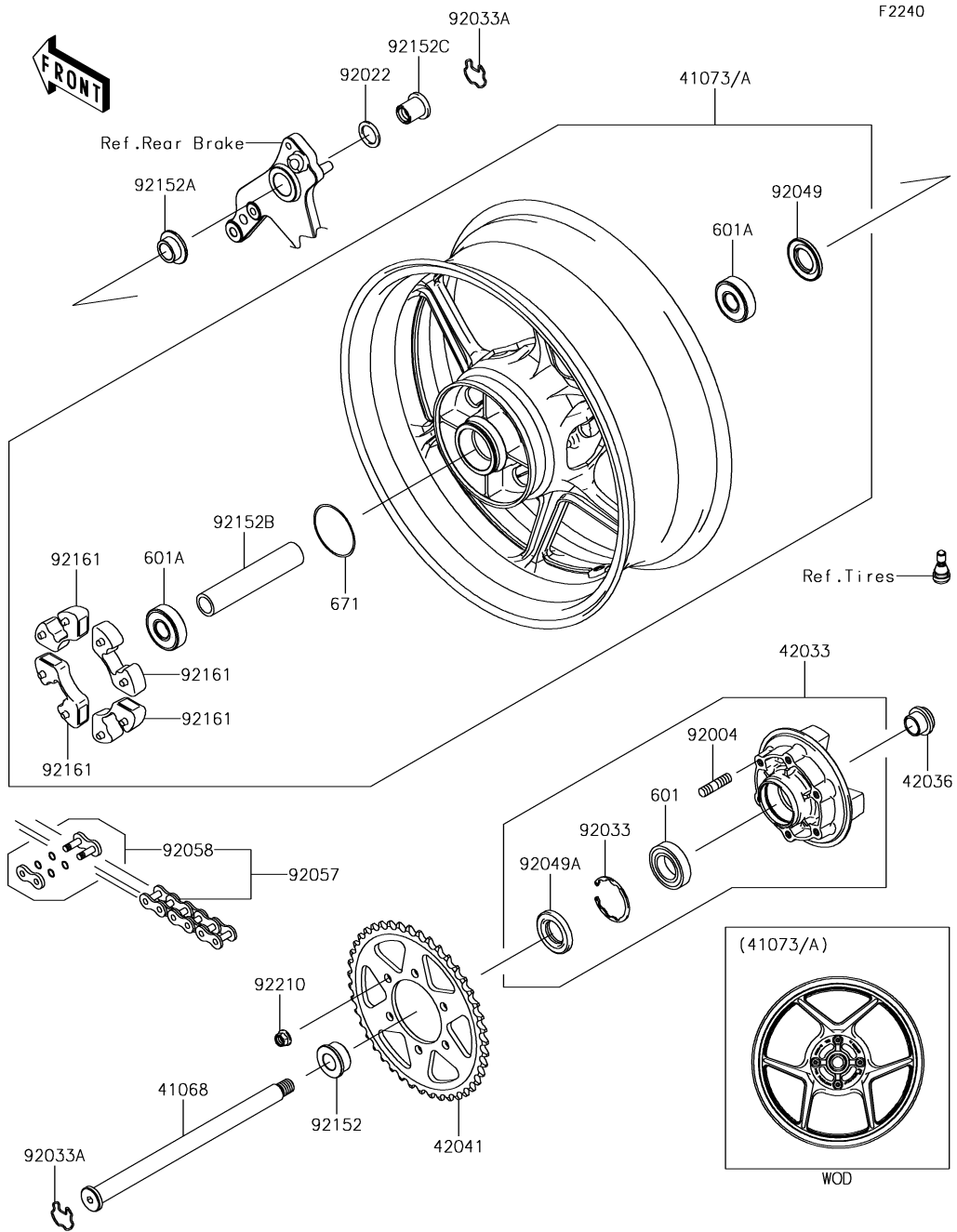

39. Rear Hub

Ref. No.	Part No.	Description	Spec Code	Quantity			
				'17	'18		
				HHF	HJF		
41068	41068-0622	AXLE,RR		1	1		
41073	41073-0613-18F	WHEEL-ASSY,RR,G.BLACK		1			
41073A	41073-0725-18F	WHEEL-ASSY,RR,G.BLACK		1	1		
42033	42033-0028	COUPLING-ASSY,RR HUB		1	1		
42036	42036-1251	SLEEVE,RR HUB,L=23		1	1		
42041	42041-0127	SPROCKET-HUB,43T		1	1		
92004	92004-0028	STUD,10X19		6	6		
92022	92022-1618	WASHER,23X32X2.3		1	1		
92033	92033-1043	RING-SNAP,52MM		1	1		
92033A	92033-1156	RING-SNAP,RR AXLE		2	2		
92049	92049-0723	SEAL-OIL,27X52X5		1	1		
92049A	92049-1287	SEAL-OIL		1	1		
92057	92057-0203	CHAIN,DRIVE,EK525ZX-112L		1	1		
92058	92058-0027	JOINT-CHAIN,DRIVE		1	1		
92152	92152-0118	COLLAR,RR AXLE,LH,L=18		1	1		
92152A	92152-0876	COLLAR,RR AXLE,RH,20X28X14.5		1	1		
92152B	92152-0892	COLLAR,RR HUB,20.2X28X144.5		1	1		
92152C	92152-2279	COLLAR,16X23X28		1	1		
92161	92161-0342	DAMPER,SHOCK,RR HUB		4	4		
92210	92210-0276	NUT,LOCK,FLANGED,10MM		6	6		
601	601B6205UU	BEARING-BALL		1	1		
601A	601B6304UU	BEARING-BALL,#6304UUC3		2	2		
671	671B2560	O RING,60MM		1	1		

40. Brake Pedal

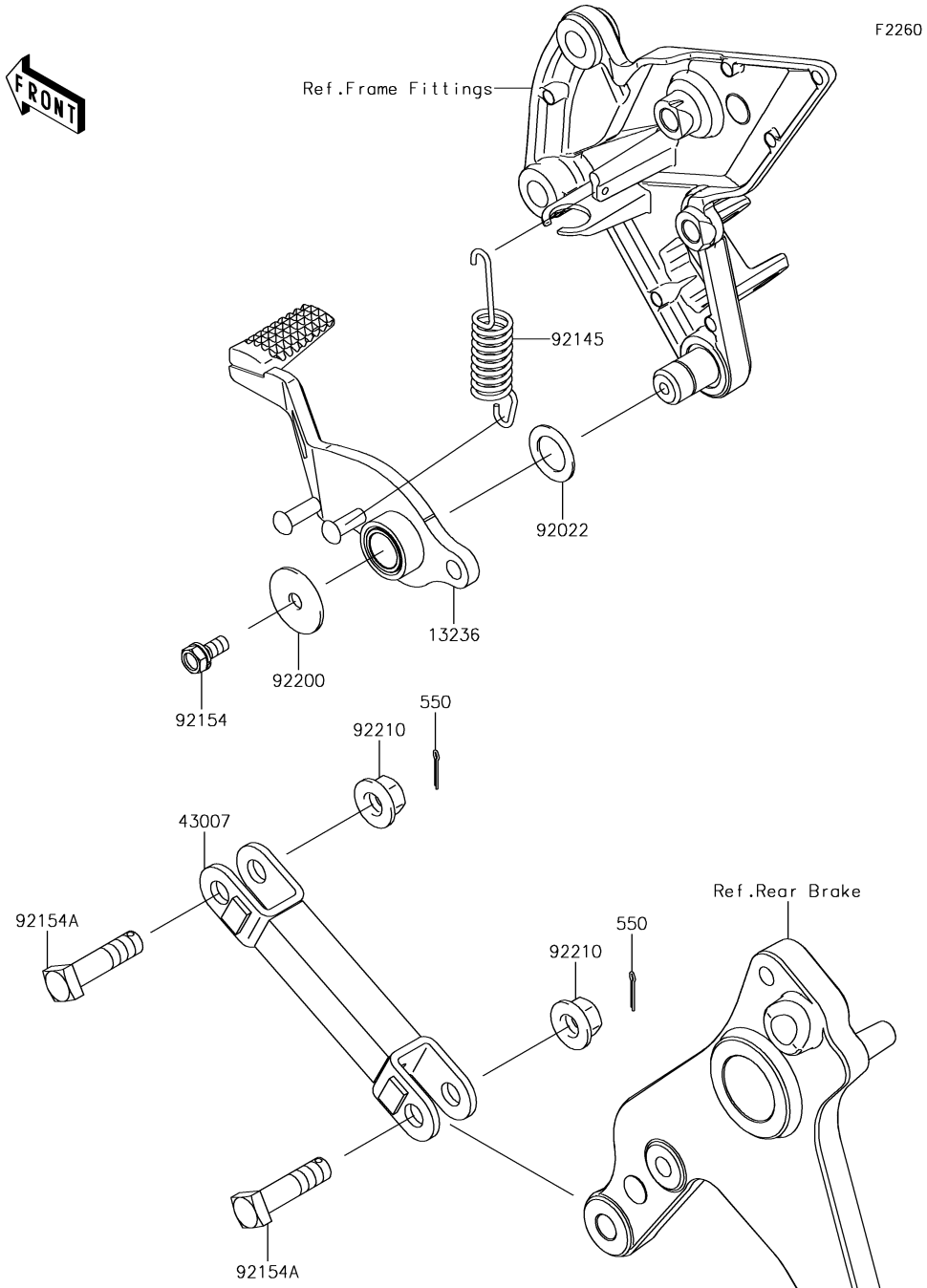

Ref. No.	Part No.	Description	Spec Code	Quantity			
				'17	'18		
				HHF	HJF		
13236	13236-0743	LEVER-COMP,BRAKE PEDAL		1	1		
43007	43007-0016-18R	ROD-TORQUE,F.S.BLACK		1	1		
92022	92022-326	WASHER,15.3X24X1		1	1		
92145	92145-1753	SPRING,2.0X70		1	1		
92154	92154-0293	BOLT,UPSET-WS,6X14		1	1		
92154A	92154-2327	BOLT,10X39.5		2	2		
92200	92200-0279	WASHER,7X28X1.6		1	1		
92210	92210-1522	NUT,FLANGED,10MM		2	2		
550	550AA2015	PIN-COTTER,2.0X15		2	2		

41. Brake Piping

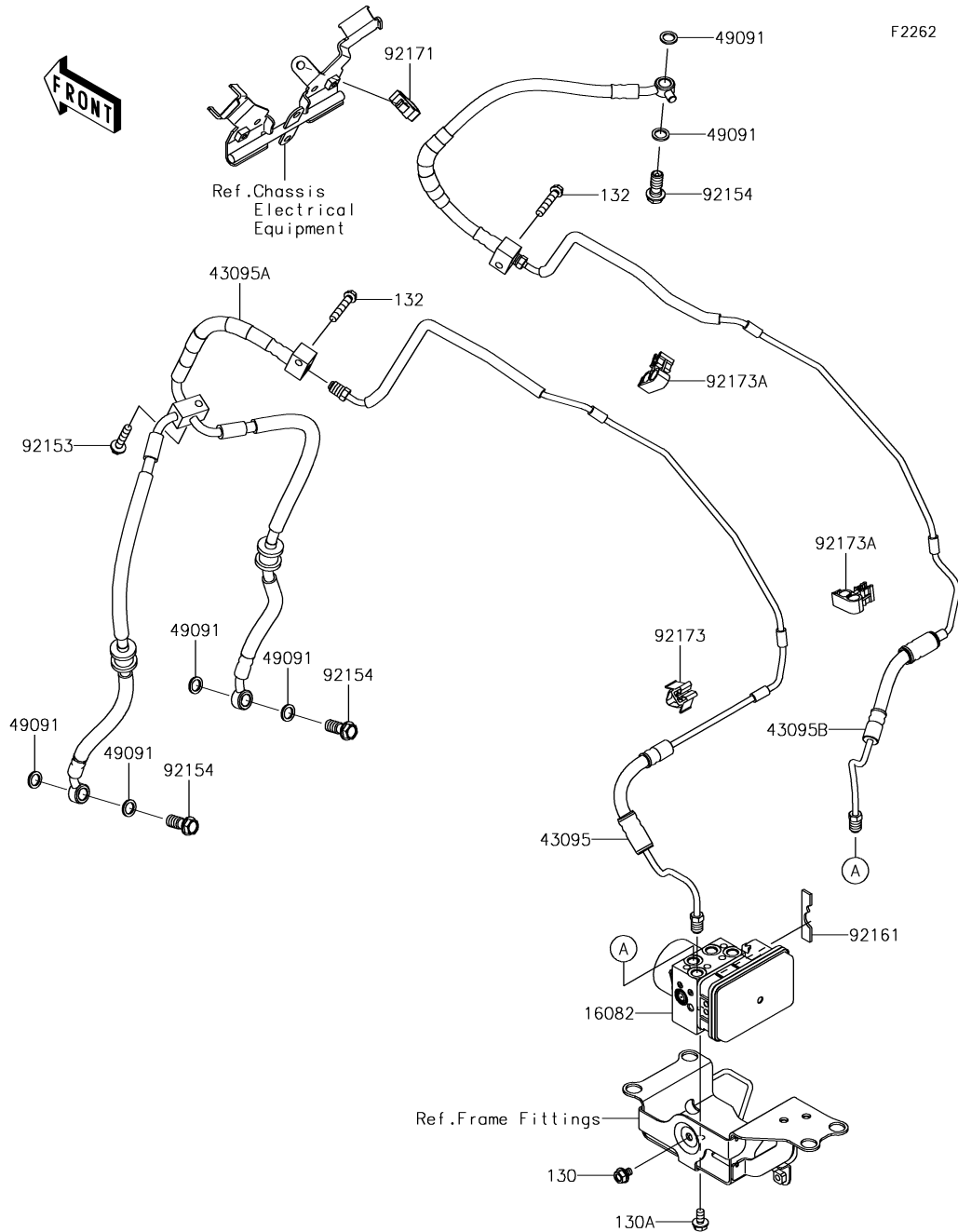

Ref. No.	Part No.	Description	Spec Code	Quantity			
				'17	'18		
				HHF	HJF		
16082	16082-0773	PUMP-ASSY-OIL,ABS,WET		1	1		
43095	43095-0981	HOSE-BRAKE,ABS UNIT-FRM HEAD		1	1		
43095A	43095-0982	HOSE-BRAKE,FRM HEAD-FR CAL.		1	1		
43095B	43095-0983	HOSE-BRAKE,ABS UNIT-FR M/CYL.		1	1		
49091	49091-0001	WASHER-SEAL,10.1X14.5X1.5		6	6		
92153	92153-1580	BOLT,FLANGED,6X28		1	1		
92154	92154-1712	BOLT,BANJO,10X23		3	3		
92161	92161-1673	DAMPER		1	1		
92171	92171-0782	CLAMP		1	1		
92173	92173-0088	CLAMP		1	1		
92173A	92173-0799	CLAMP,CLIP		2	2		
130	130BA0608	BOLT-FLANGED,6X8		1	1		
130A	130BA0612	BOLT-FLANGED,6X12		1	1		
132	132BB0630	BOLT-FLANGED-SMALL,6X30		2	2		

42. Front Master Cylinder

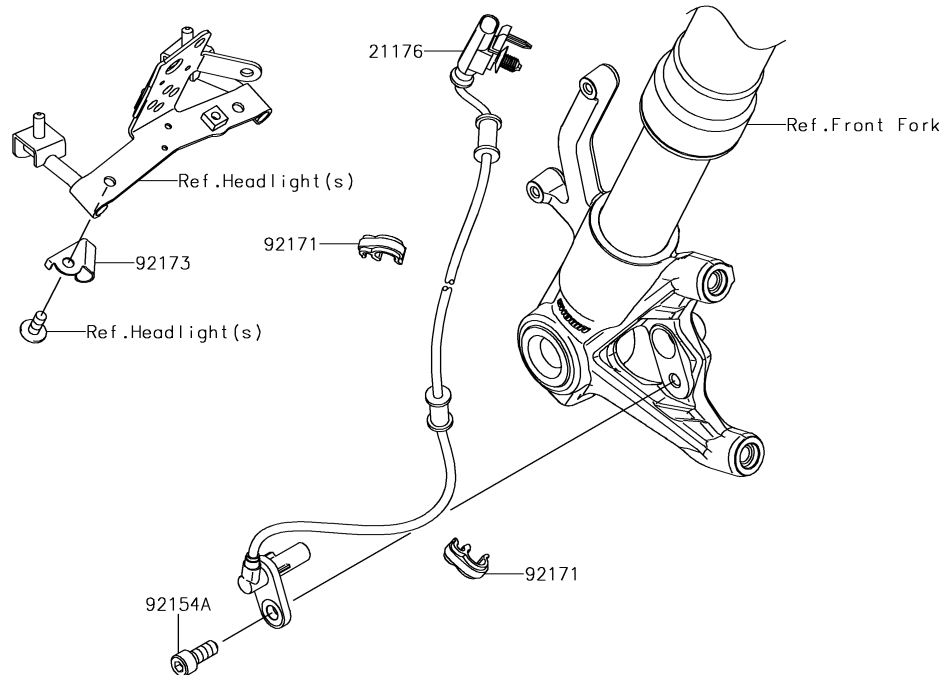
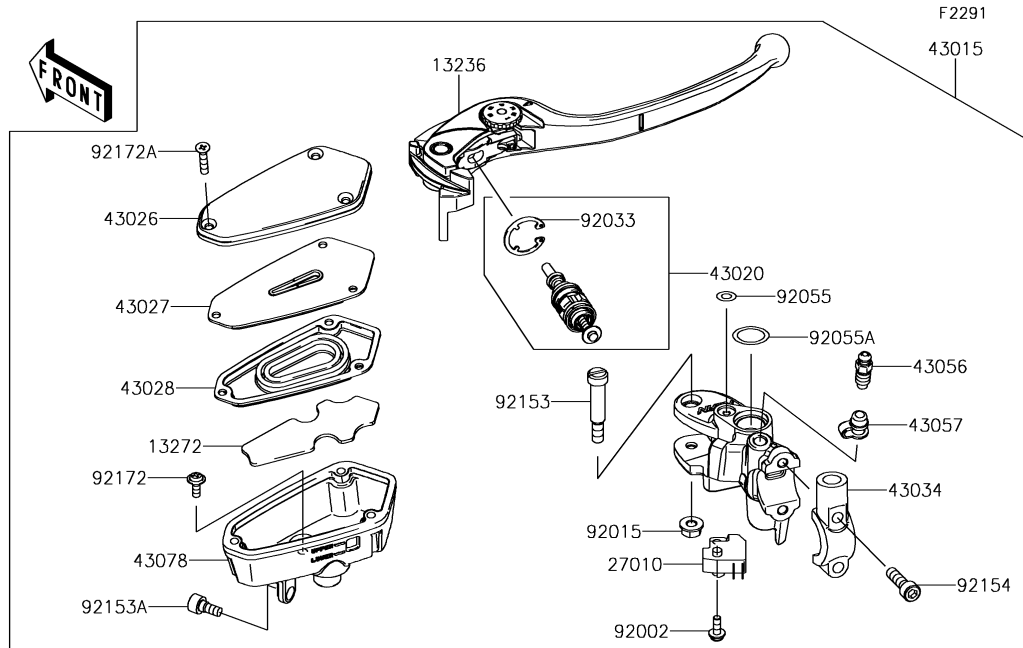

Ref. No.	Part No.	Description	Spec Code	Quantity			
				'17	'18		
				HHF	HJF		
13236	13236-0729	LEVER-COMP		1	1		
13272	13272-1719	PLATE		1	1		
21176	21176-0841	SENSOR,WHEEL SPEED,FR		1	1		
27010	27010-0762	SWITCH,BRAKE		1	1		
43015	43015-0651	CYLINDER-ASSY-MASTER,FR		1	1		
43020	43020-0020	PISTON-COMP-BRAKE		1	1		
43026	43026-0011	CAP-BRAKE		1	1		
43027	43027-0003	PLATE-DIAPHRAGM		1	1		
43028	43028-0008	DIAPHRAGM		1	1		
43034	43034-0057	HOLDER-BRAKE,MASTER CYLINDER		1	1		
43056	43056-1056	BREATHER-BRAKE		1	1		
43057	43057-1001	CAP-BREATHER		1	1		
43078	43078-0569	RESERVOIR		1	1		
92002	92002-1323	BOLT,SCREW,4X12		1	1		
92015	92015-1528	NUT,FLANGED,6MM		1	1		
92033	92033-0034	RING-SNAP		1	1		
92055	92055-0137	RING-O		1	1		
92055A	92055-0741	RING-O,14.8X2.4		1	1		
92153	92153-0868	BOLT,LEVER		1	1		
92153A	92153-1853	BOLT,SOCKET,6X12		1	1		
92154	92154-1271	BOLT,SOCKET,6X22		2	2		
92154A	92154-1976	BOLT,SOCKET,8X20		1	1		
92171	92171-1819	CLAMP,BRAKE HOSE		2	2		
92172	92172-0319	SCREW		1	1		
92172A	92172-0855	SCREW,4X20		3	3		
92173	92173-1112	CLAMP,SPEED SENSOR		1	1		

F2292

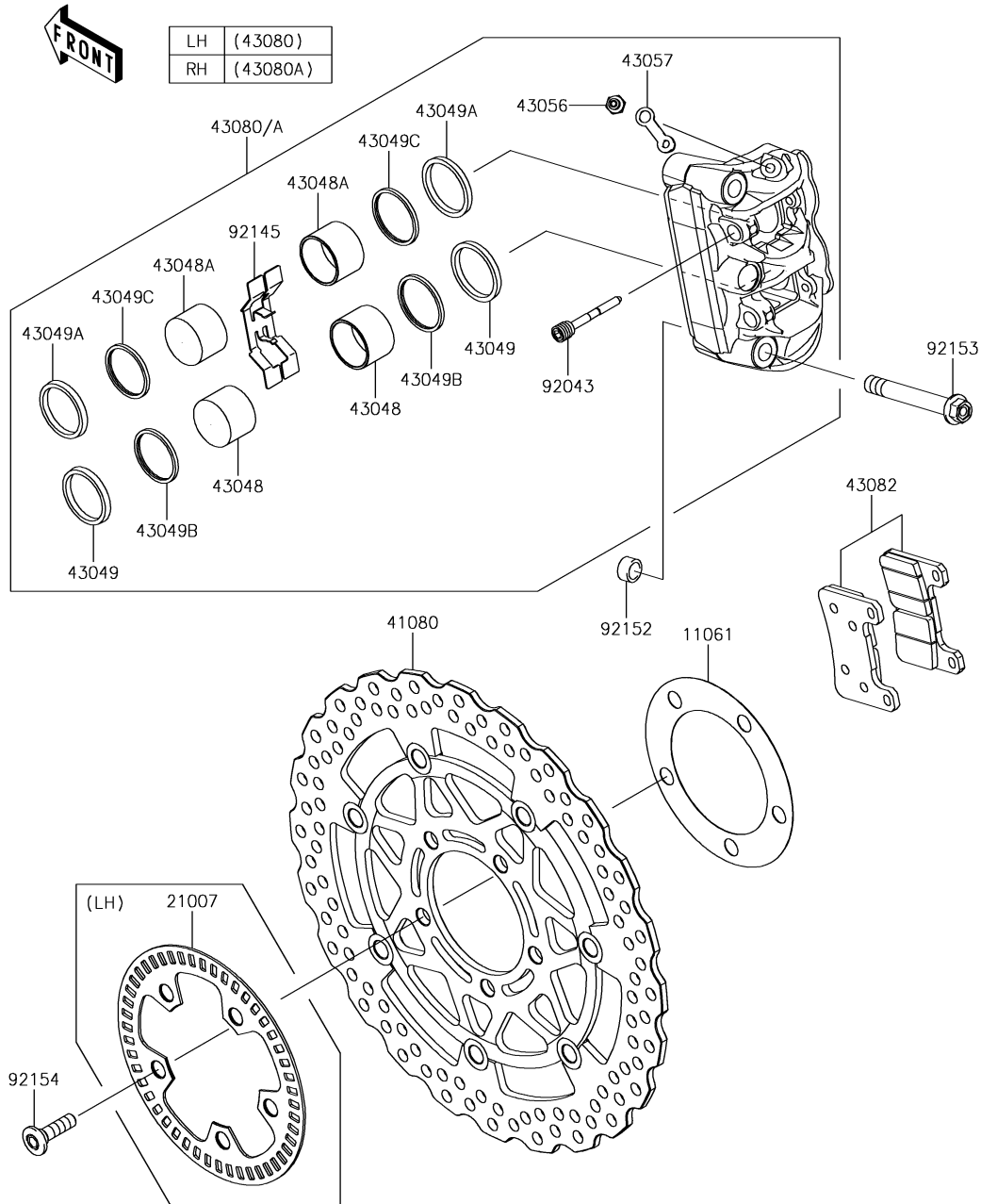

43. Front Brake

Ref. No.	Part No.	Description	Spec Code	Quantity	
				'17	'18
				HHF	HJF
11061	11061-0029	GASKET,DISC PLATE		2	2
21007	21007-0166	ROTOR,FR WHEEL		1	1
41080	41080-0602-5C	DISC,FR,HOUSING BLK+DISC SIL		2	2
43048	43048-0023	PISTON-CALIPER		4	4
43048A	43048-0024	PISTON-CALIPER		4	4
43049	43049-0012	PACKING,PISTON		4	4
43049A	43049-0013	PACKING,PISTON		4	4
43049B	43049-1068	PACKING		4	4
43049C	43049-1107	PACKING,WIPER		4	4
43056	43056-0007	BREATHER-BRAKE		2	2
43057	43057-003	CAP-BREATHER		2	2
43080	43080-0143-DJ	CALIPER-SUB-ASSY,FR,LH,BLACK		1	1
43080A	43080-0144-DJ	CALIPER-SUB-ASSY,FR,RH,BLACK		1	1
43082	43082-0147	PAD-ASSY-BRAKE		2	2
92043	92043-1709	PIN,PAD		4	4
92145	92145-0580	SPRING,PAD		2	2
92152	92152-0679	COLLAR,DOWEL PIN		4	4
92153	92153-1890	BOLT,FLANGED,10X73		4	4
92154	92154-1865	BOLT,SOCKET,8X30		10	10

44. Rear Master Cylinder

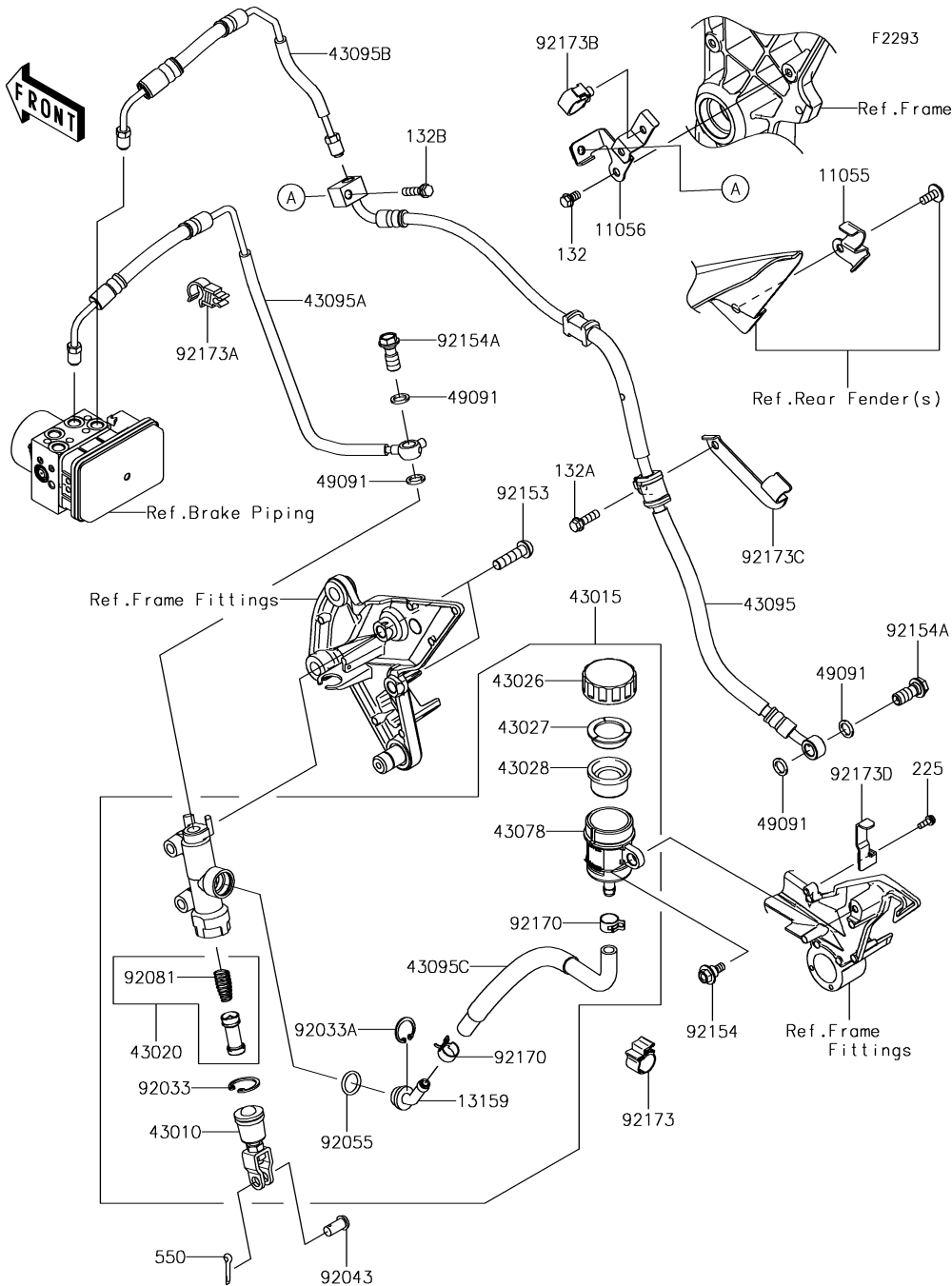

Ref. No.	Part No.	Description	Spec Code	Quantity			
				'17	'18		
				HHF	HJF		
11055	11055-1785	BRACKET	1	1			
11056	11056-3887	BRACKET	1	1			
13159	13159-0008	CONNECTOR	1	1			
43010	43010-1062	ROD-ASSY-BRAKE	1	1			
43015	43015-0596	CYLINDER-ASSY-MASTER,RR	1	1			
43020	43020-1057	PISTON-COMP-BRAKE	1	1			
43026	43026-0009	CAP-BRAKE	1	1			
43027	43027-1053	PLATE-DIAPHRAGM	1	1			
43028	43028-1065	DIAPHRAGM	1	1			
43078	43078-0060	RESERVOIR	1	1			
43095	43095-0510	HOSE-BRAKE,RR	1	1			
43095A	43095-0785	HOSE-BRAKE,HU-RR M/C	1	1			
43095B	43095-0786	HOSE-BRAKE,HU-RR CALIPER	1	1			
43095C	43095-0811	HOSE-BRAKE,RR M/C	1	1			
49091	49091-0001	WASHER-SEAL,10.1X14.5X1.5	4	4			
92033	92033-0079	RING-SNAP,20.9X24.6X1.2	1	1			
92033A	92033-1186	RING-SNAP,20.5MM	1	1			
92043	92043-0904	PIN	1	1			
92055	92055-0741	RING-O,14.8X2.4	1	1			
92081	92081-1737	SPRING,MASTER CYLINDER	1	1			
92153	92153-0393	BOLT,SOCKET,8X30	2	2			
92154	92154-0385	BOLT,FLANGED,6X16	1	1			
92154A	92154-1712	BOLT,BANJO,10X23	2	2			
92170	92170-1091	CLAMP,HOSE	2	2			
92173	92173-0127	CLAMP,CLIP	1	1			
92173A	92173-0170	CLAMP	1	1			
92173B	92173-0868	CLAMP,HOLDER CLIP	1	1			
92173C	92173-1248	CLAMP	1	1			
92173D	92173-1694	CLAMP	1	1			
132	132BA0610	BOLT-FLANGED-SMALL,6X10	1	1			
132A	132BA0620	BOLT-FLANGED-SMALL,6X20	1	1			
132B	132BA0625	BOLT-FLANGED-SMALL,6X25	1	1			
225	225AB0412	SCREW-PAN-WSP-CROS,4X12	1	1			
550	550AA2015	PIN-COTTER,2.0X15	1	1			

'17-'18 ZR1000 HHF/HJF

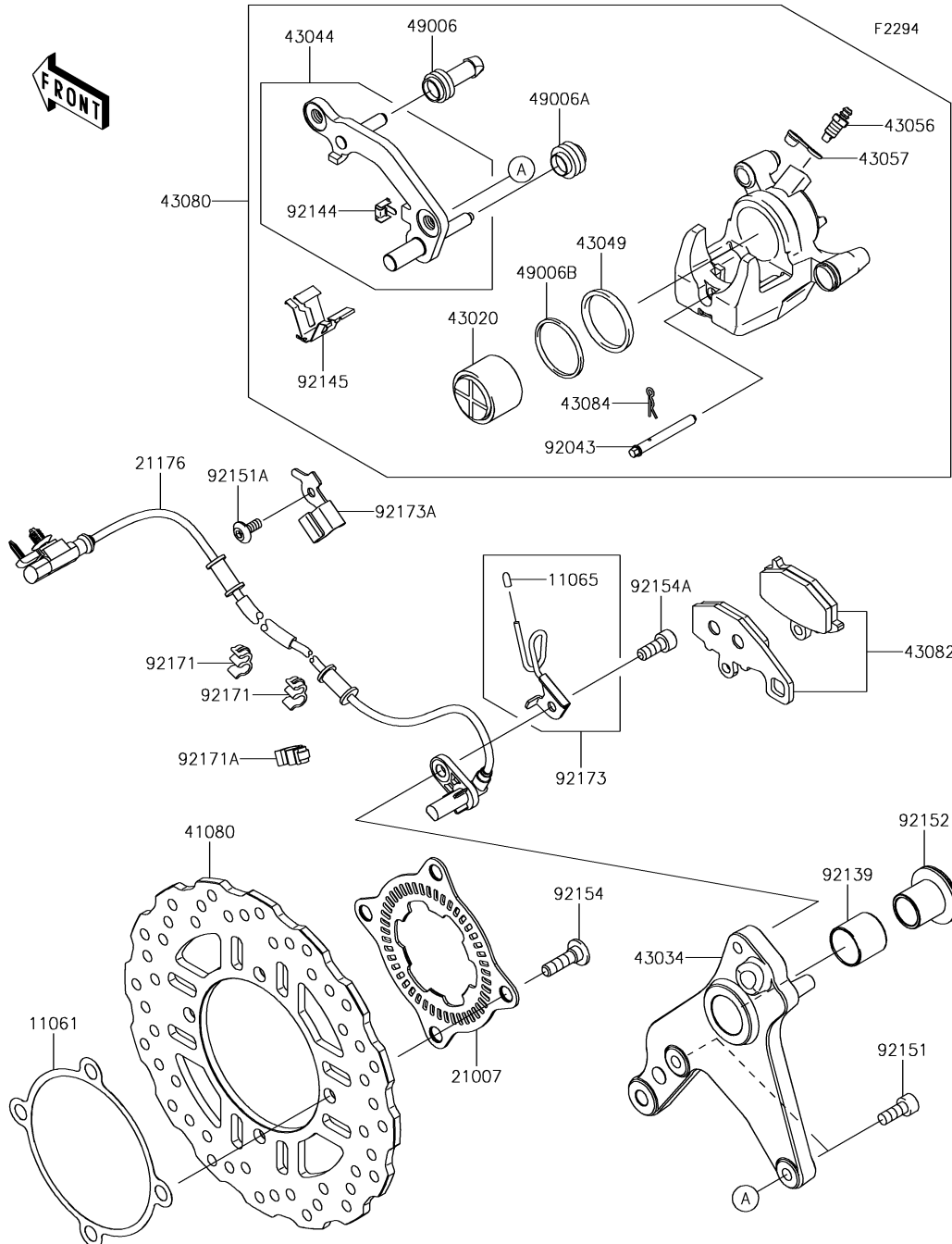

45. Rear Brake

Ref. No.	Part No.	Description	Spec Code	Quantity			
				'17	'18		
				HHF	HJF		
11061	11061-0204	GASKET,DISC PLATE		1	1		
11065	11065-0374	CAP		1	1		
21007	21007-0141	ROTOR,SENSOR,RR		1	1		
21176	21176-0836	SENSOR,WHEEL SPEED,RR		1	1		
41080	41080-0632	DISC,RR		1	1		
43020	43020-1119	PISTON-COMP-BRAKE		1	1		
43034	43034-0110	HOLDER-BRAKE,RR		1	1		
43044	43044-0074	HOLDER-COMP-CALIPER,RR		1	1		
43049	43049-1097	PACKING,PISTON SEAL		1	1		
43056	43056-0007	BREATHER-BRAKE		1	1		
43057	43057-003	CAP-BREATHER		1	1		
43080	43080-0141-DJ	CALIPER-SUB-ASSY,RR,BLACK		1	1		
43082	43082-0167	PAD-ASSY-BRAKE		1	1		
43084	43084-003	CLAMP,PAD		1	1		
49006	49006-1054	BOOT,CALIPER		1	1		
49006A	49006-1095	BOOT,CALIPER		1	1		
49006B	49006-1212	BOOT,PISTON SEAL		1	1		
92043	92043-1489	PIN,PAD		1	1		
92139	92139-0278	BUSHING,25X28X25		1	1		
92144	92144-1831	SPRING,STOPPER		1	1		
92145	92145-0760	SPRING		1	1		
92151	92151-1289	BOLT,SOCKET,8X20		2	2		
92151A	92151-1654	BOLT,SOCKET,6X14		1	1		
92152	92152-1960	COLLAR,20X25X30		1	1		
92154	92154-1865	BOLT,SOCKET,8X30		4	4		
92154A	92154-1976	BOLT,SOCKET,8X20		1	1		
92171	92171-0921	CLAMP		2	2		
92171A	92171-1819	CLAMP,BRAKE HOSE		1	1		
92173	92173-1099	CLAMP		1	1		
92173A	92173-1144	CLAMP,RR WHEEL SPEED SENSOR		1	1		

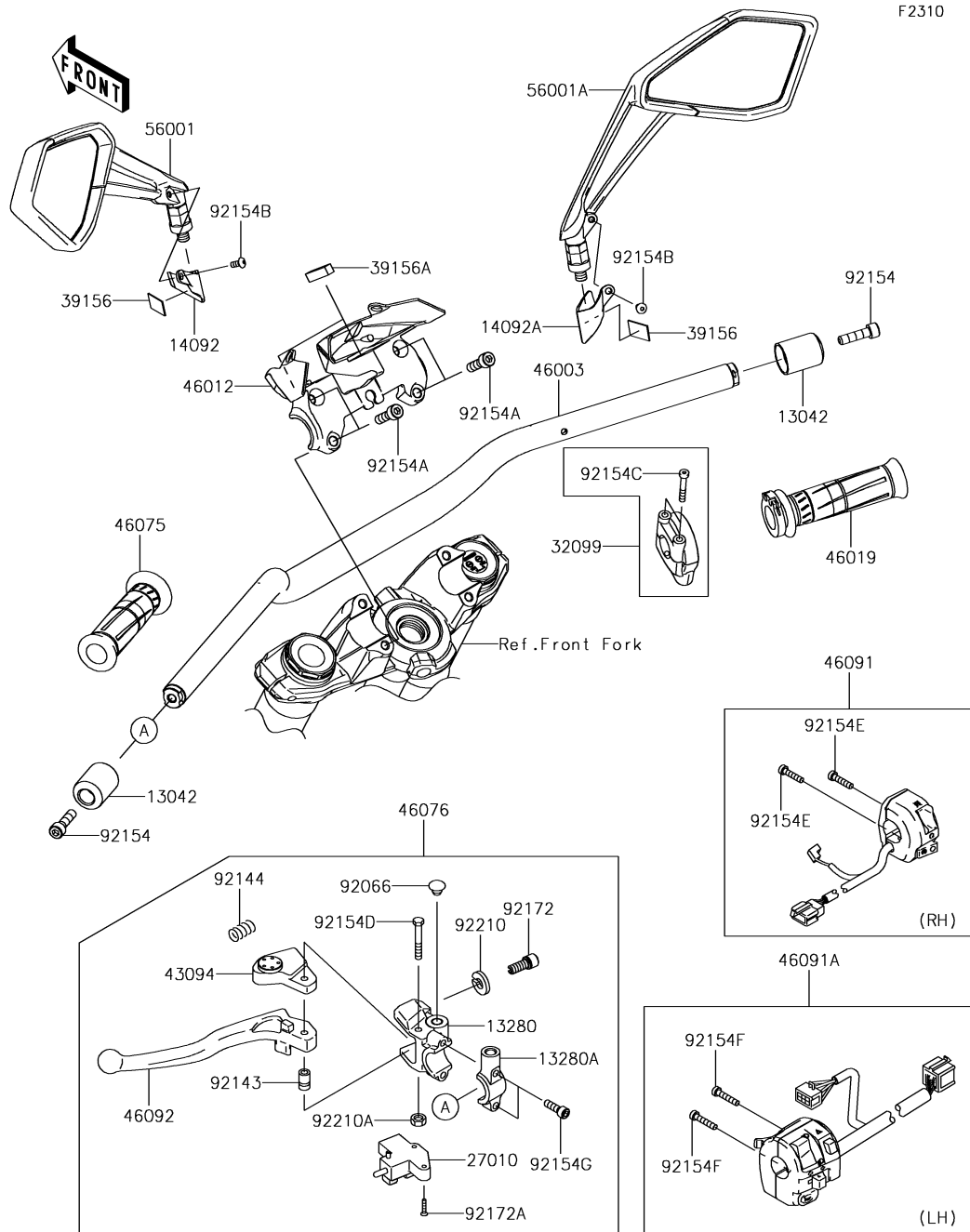

46. Handlebar

Ref. No.	Part No.	Description	Spec Code	Quantity			
				'17	'18		
				HHF	HJF		
13042	13042-5001	WEIGHT,HANDLE	2	2			
13280	13280-0248	HOLDER,CLUTCH LEVER	1	1			
13280A	13280-0772	HOLDER,CLUTCH LEVER	1	1			
14092	14092-1156	COVER,MIRROR STAY,LH	1	1			
14092A	14092-1157	COVER,MIRROR STAY,RH	1	1			
27010	27010-0854	SWITCH,CLUTCH	1	1			
32099	32099-0767	CASE,THROTTLE	1	1			
39156	39156-1747	PAD,15X25X1	2	2			
39156A	39156-1810	PAD,7.5X30X8	2	2			
43094	43094-0008	ADJUSTER	1	1			
46003	46003-0632	HANDLE,FAT BAR	1	1			
46012	46012-0347-18R	HOLDER-HANDLE,F.S.BLACK	1	1			
46019	46019-0020	GRIP-ASSY,THROTTLE	1	1			
46075	46075-0068	GRIP,LH	1	1			
46076	46076-0125	LEVER-ASSY-GRIP,CLUTCH,W/ADJ.	1	1			
46091	46091-0357	HOUSING-ASSY-CONTROL,RH	1	1			
46091A	46091-0359	HOUSING-ASSY-CONTROL,LH	1	1			
46092	46092-0568	LEVER-GRIP	1	1			
56001	56001-0343-46V	MIRROR-ASSY,LH,L.S.BLACK	1	1			
56001A	56001-0344-46V	MIRROR-ASSY,RH,L.S.BLACK	1	1			
92066	92066-1077	PLUG,9.5X8,POLYETHYLENE	1	1			
92143	92143-1379	COLLAR	1	1			
92144	92144-1467	SPRING	1	1			
92154	92154-0502	BOLT,SOCKET,8X30	2	2			
92154A	92154-1236	BOLT,SOCKET,8X25	4	4			
92154B	92154-1292	BOLT,SOCKET,5X10	2	2			
92154C	92154-1530	BOLT,SOCKET,5X35	2	2			
92154D	92154-2318	BOLT	1	1			
92154E	92154-2483	BOLT,5X22	2	2			
92154F	92154-2596	BOLT,SOCKET,5X25	2	2			
92154G	92154-2644	BOLT,SOCKET,6X20	2	2			
92172	92172-1138	SCREW	1	1			
92172A	92172-1185	SCREW,3X16	2	2			
92210	92210-1519	NUT	1	1			
92210A	92210-1544	NUT,LOCK,6MM	1	1			

47. Front Fork

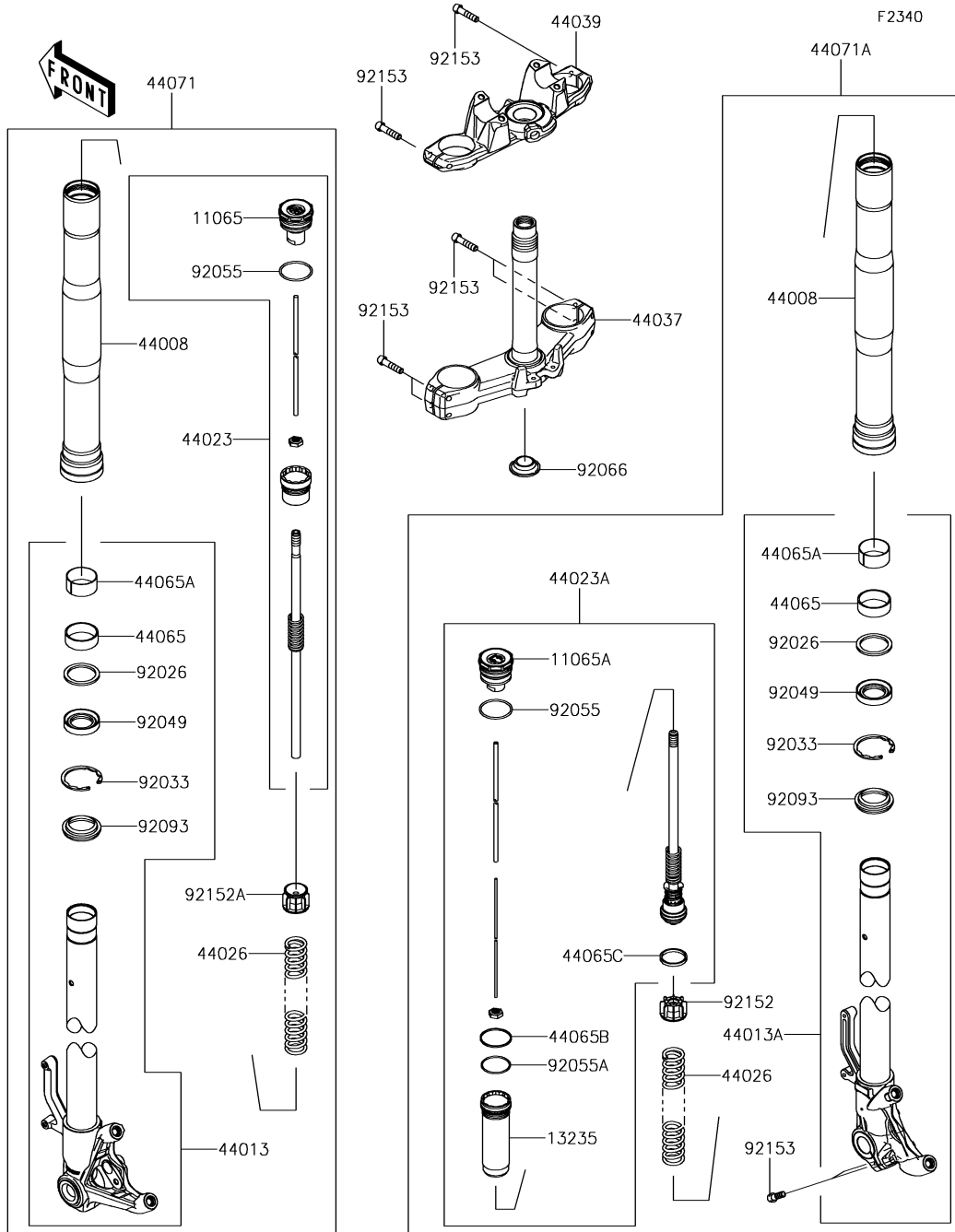

Ref. No.	Part No.	Description	Spec Code	Quantity				
				'17	'18			
				HHF	HJF			
11065	11065-0947-11G	CAP,LH,GRAY			1	1		
11065A	11065-0948-11G	CAP,RH,GRAY			1	1		
13235	13235-0008	GUIDE-COMP,ROD			1	1		
44008	44008-0070-499	PIPE-FORK OUTER,A.BLACK			2	2		
44013	44013-0221-18R	PIPE-FORK INNER,LH,F.S.BLACK			1	1		
44013A	44013-0222-18R	PIPE-FORK INNER,RH,F.S.BLACK			1	1		
44023	44023-0136-11G	CYLINDER-SET-FORK,LH,GRAY			1	1		
44023A	44023-0137-11G	CYLINDER-SET-FORK,RH,GRAY			1	1		
44026	44026-0180	SPRING-FRONT FORK			2	2		
44037	44037-0141-18R	HOLDER-FORK UNDER,F.S.BLACK			1	1		
44039	44039-0136-18R	HOLDER-FORK UPPER,F.S.BLACK			1	1		
44065	44065-0030	BUSHING-FRONT FORK,GUIDE			2	2		
44065A	44065-0031	BUSHING-FRONT FORK,SLIDE			2	2		
44065B	44065-0033	BUSHING-FRONT FORK			1	1		
44065C	44065-0047	BUSHING-FRONT FORK			1	1		
44071	44071-1241-48T	DAMPER-ASSY,FORK,LH,BLACK			1	1		
44071A	44071-1242-48T	DAMPER-ASSY,FORK,RH,BLACK			1	1		
92026	92026-1276	SPACER,FORK OUTER			2	2		
92033	92033-0729	RING-SNAP			2	2		
92049	92049-0125	SEAL-OIL			2	2		
92055	92055-0142	RING-O			2	2		
92055A	92055-0174	RING-O			1	1		
92066	92066-0032	PLUG			1	1		
92093	92093-0035	SEAL,DUST			2	2		
92152	92152-0757	COLLAR			1	1		
92152A	92152-1888	COLLAR			1	1		
92153	92153-0854	BOLT,SOCKET,8X35			8	8		

F2410

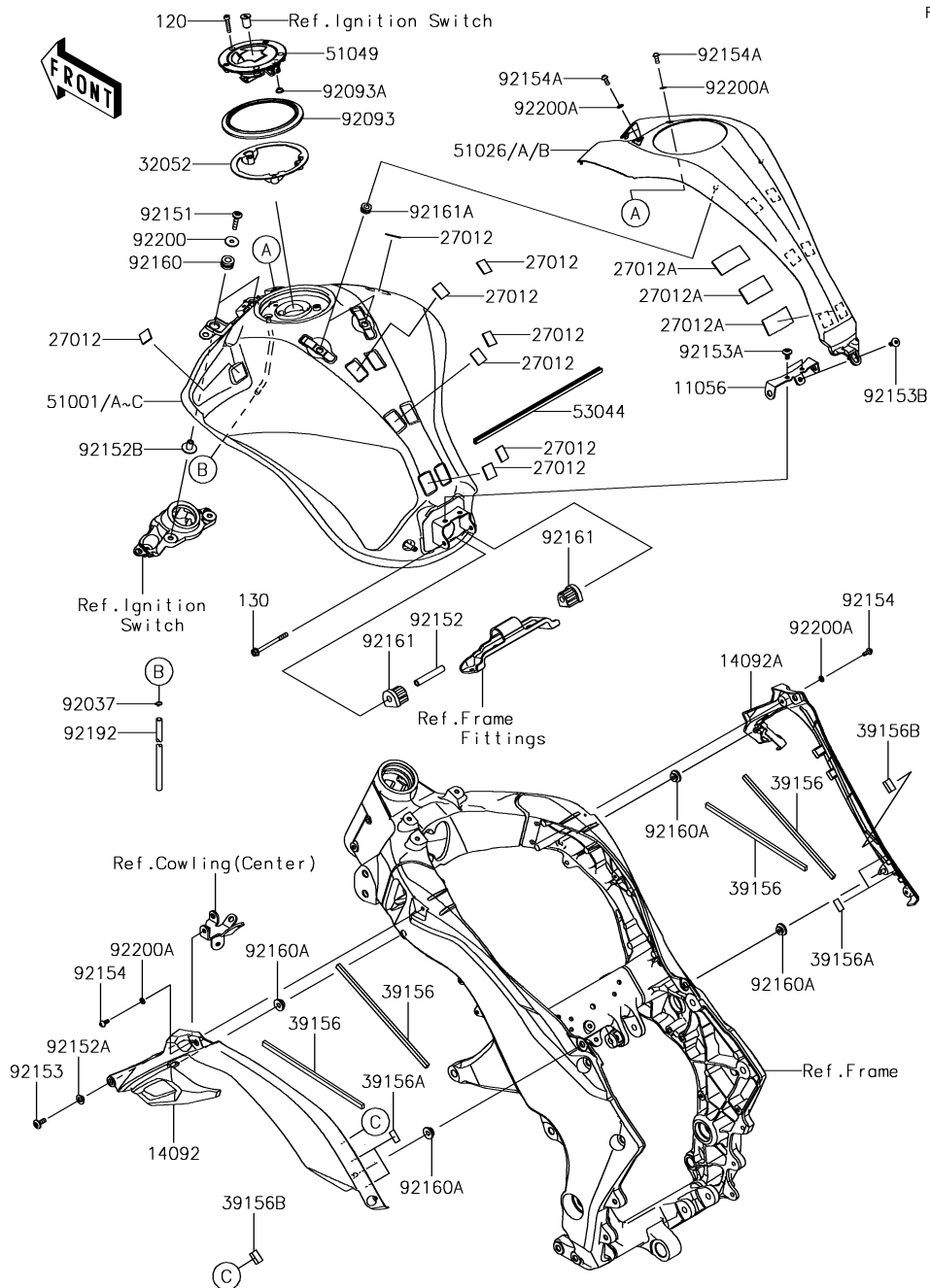

48. Fuel Tank

Ref. No.	Part No.	Description	Spec Code	Quantity			
				'17	'18		
				HHF	HJF		
11056	11056-3839	BRACKET	1	1			
14092	14092-1128	COVER,KNEE GRIP,LH	1	1			
14092A	14092-1129	COVER,KNEE GRIP,RH	1	1			
27012	27012-0171	HOOK	8	8			
27012A	27012-0764	HOOK,FASTENER,28X57	3	3			
32052	32052-0744	BRACKET-TANK	1	1			
39156	39156-0563	PAD	4	4			
39156A	39156-1784	PAD,15X20X0.2	4	4			
39156B	39156-1968	PAD,20X8X10	2	2			
51001	51001-0791-17L	TANK-COMP-FUEL,C.B.ORANGE	1				
51001A	51001-0791-36S	TANK-COMP-FUEL,P.S.GRAY		1			
51001B	51001-0791-60R	TANK-COMP-FUEL,E.B.GREEN		1			
51001C	51001-0791-660	TANK-COMP-FUEL,M.S.BLACK	1				
51026	51026-0010-25V	COVER TANK,C.S.BLUE		1			
51026A	51026-0010-40R	COVER TANK,G.B.GREEN	1				
51026B	51026-0010-45L	COVER TANK,F.EBONY	1	1			
51049	51049-0039	CAP-TANK,FUEL	1	1			
53044	53044-1296	TRIM	1	1			
92037	92037-010	CLAMP,TUBE	1	1			
92093	92093-0604	SEAL,TANK CAP	1	1			
92093A	92093-1030	SEAL,FUEL TANK CAP	1	1			
92151	92151-1605	BOLT,SOCKET,6X30	2	2			
92152	92152-1182	COLLAR,6.8X10X60	1	1			
92152A	92152-1863	COLLAR,6.5X10X5.3	1	1			
92152B	92152-2331	COLLAR,6.4X9.5X15.1	2	2			
92153	92153-1526	BOLT,SOCKET,6X16	1	1			
92153A	92153-1948	BOLT,SOCKET,6X12	2	2			
92153B	92153-1956	BOLT,SOCKET,6MM	1	1			
92154	92154-0917	BOLT,SOCKET,5X12	2	2			
92154A	92154-1421	BOLT,SOCKET,5X12	2	2			
92160	92160-1167	DAMPER,10X20X12	2	2			
92160A	92160-1613	DAMPER	4	4			
92161	92161-1330	DAMPER,FUEL TANK,RR	2	2			
92161A	92161-1584	DAMPER,8.2X16X8.3	2	2			
92192	92192-1024	TUBE,6X9X926(30)	1	1			
92200	92200-1087	WASHER,6.5X22X1.6	2	2			
92200A	92200-1820	WASHER,5.2X10X1.0	4	4			
120	120CC0525	BOLT-SOCKET,5X25	3	3			
130	130BB0670	BOLT-FLANGED,6X70	1	1			

F2510

49. Seat

Ref. No.	Part No.	Description	Spec Code	Quantity			
				'17	'18		
				HHF	HJF		
39156	39156-1794	PAD,RR SEAT		1	1		
53003	53003-0362-MA	LEATHER,FR SEAT,BLACK		1	1		
53003A	53003-0386-41C	LEATHER,RR SEAT,M.F.B.GREEN		1			
53003B	53003-0386-MA	LEATHER,RR SEAT,BLACK		1	1		
53066	53066-0409-12Y	SEAT-ASSY,FR,BLK+BAND BLK		1	1		
53066A	53066-0550-41C	SEAT-ASSY,RR,M.F.B.GREEN		1			
53066B	53066-0550-MA	SEAT-ASSY,RR,BLACK		1	1		
92075	92075-1927	DAMPER,10X20X8		4	4		
92161	92161-1608	DAMPER,20X40X15		1	1		

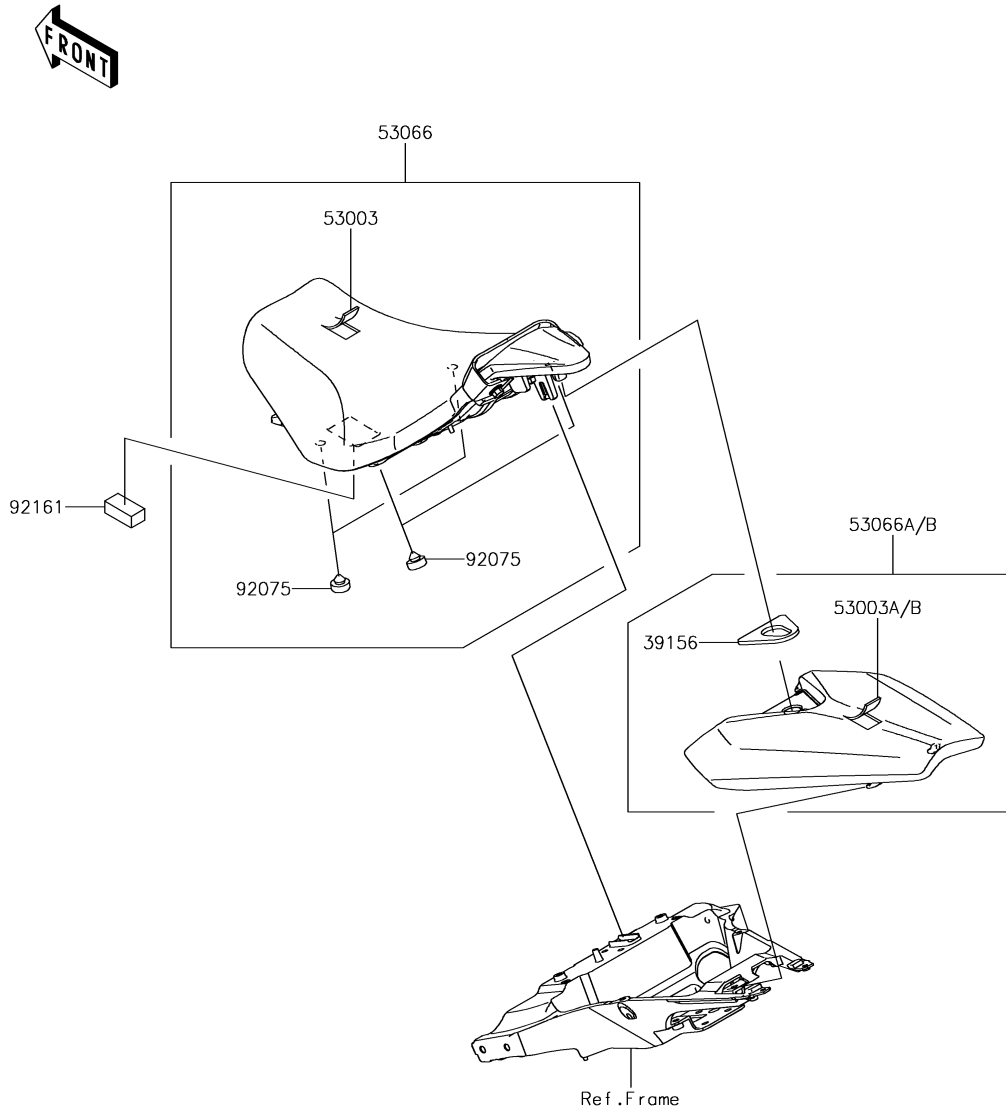

F2530

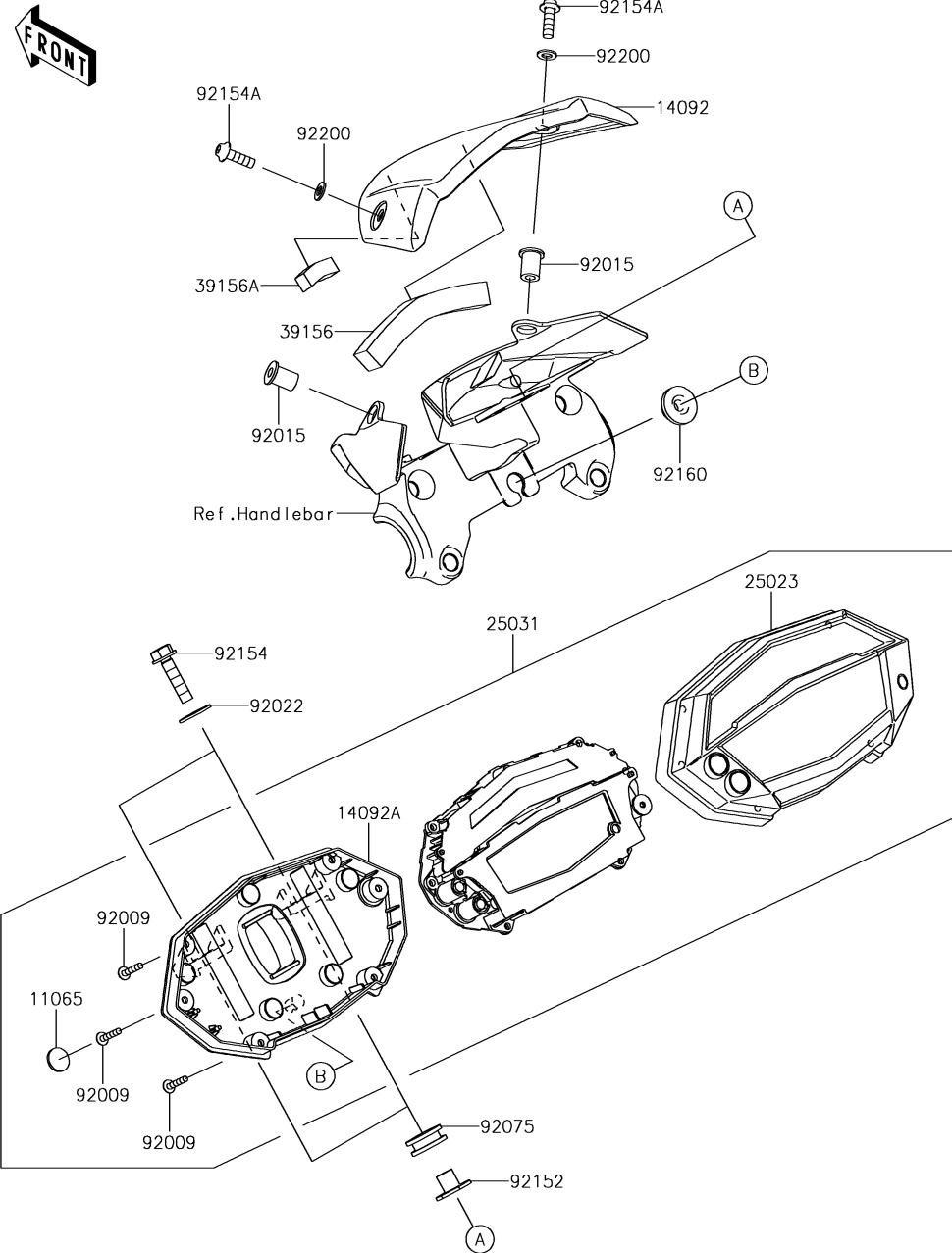

50. Meter(s)

Ref. No.	Part No.	Description	Spec Code	Quantity			
				'17	'18		
				HHF	HJF		
11065	11065-0836	CAP,WATERPROOF	2	2			
14092	14092-1133	COVER,METER	1	1			
14092A	14092-1164	COVER,LWR CASE	1	1			
25023	25023-0094	COVER-METER CASE,UPP	1	1			
25031	25031-0726	METER-ASSY,COMBINATION,ABS	1	1			
39156	39156-1796	PAD,RUBBER,12X90X12	1	1			
39156A	39156-1809	PAD,12X10X8	1	1			
92009	92009-1391	SCREW,TAPPING,3X16	6	6			
92015	92015-1757	NUT,WELL,5MM	2	2			
92022	92022-1369	WASHER,6.2X18X1.2	2	2			
92075	92075-1634	DAMPER	2	2			
92152	92152-2075	COLLAR,6X9X11.1	2	2			
92154	92154-0707	BOLT,FLANGED,6X25	2	2			
92154A	92154-1701	BOLT,SOCKET,5X16	2	2			
92160	92160-1613	DAMPER	1	1			
92200	92200-1820	WASHER,5.2X10X1.0	2	2			

F2540

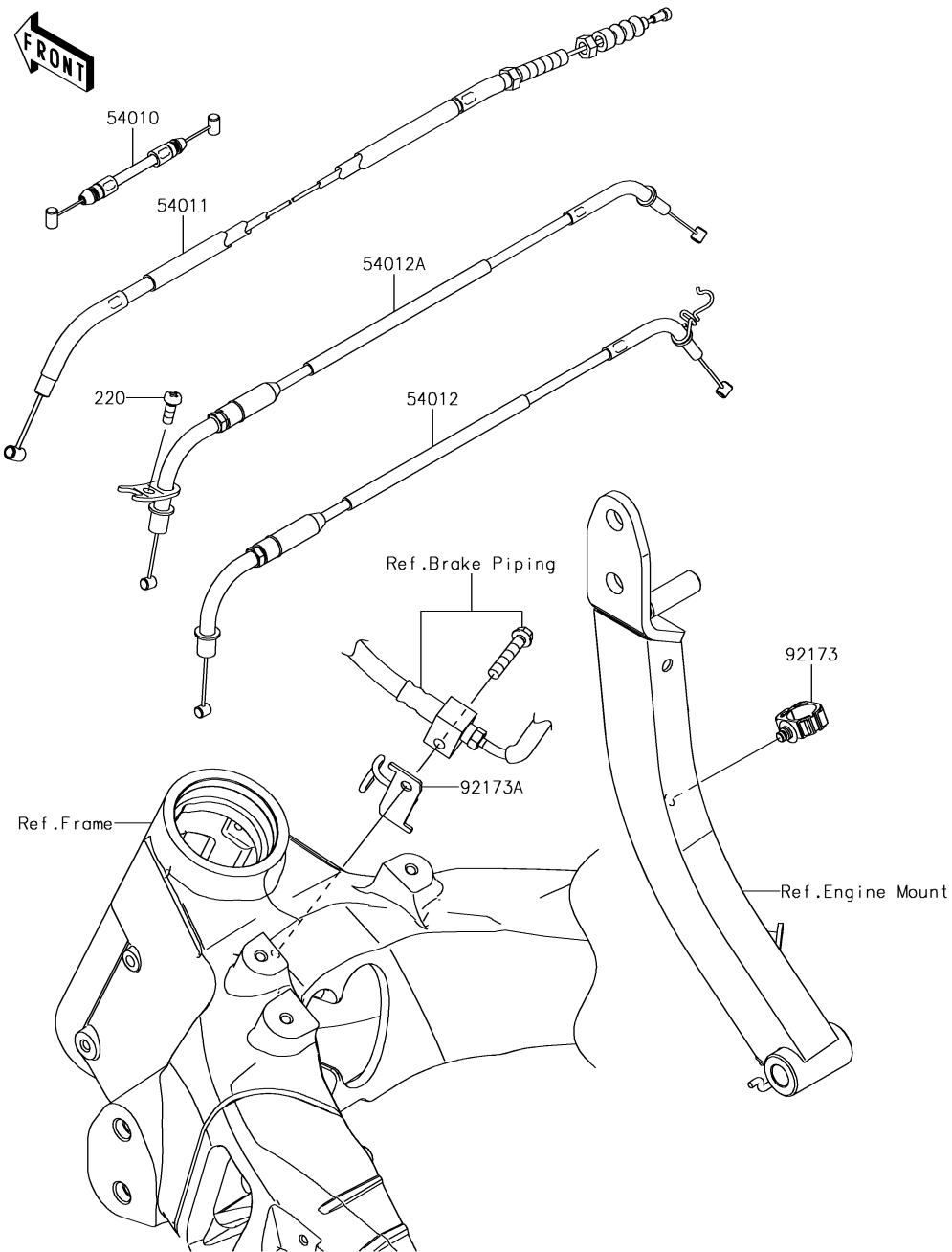

51. Cables

Ref. No.	Part No.	Description	Spec Code	Quantity			
				'17	'18		
				HHF	HJF		
54010	54010-0597	CABLE,SEAT LOCK	1	1			
54011	54011-0619	CABLE-CLUTCH	1	1			
54012	54012-0601	CABLE-THROTTLE,OPENING	1	1			
54012A	54012-0602	CABLE-THROTTLE,CLOSING	1	1			
92173	92173-0868	CLAMP,HOLDER CLIP	1	1			
92173A	92173-1606	CLAMP,FRM HEAD	1	1			
220	220AB0614	SCREW-PAN-CROS,6X14	1	1			

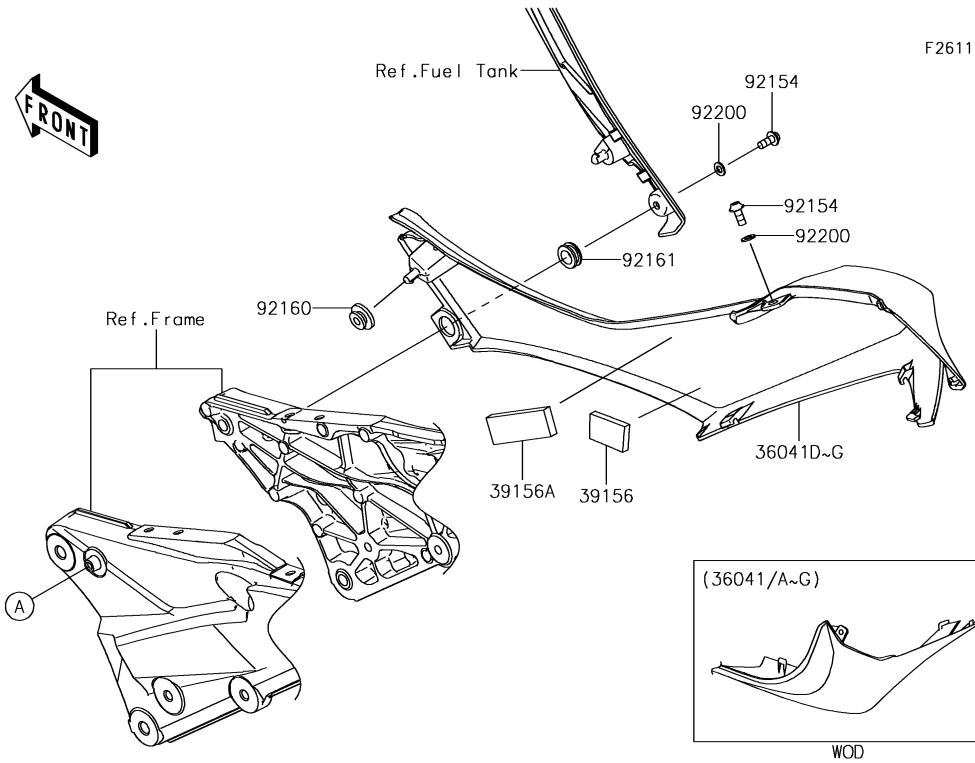

F2611

Ref. No.	Part No.	Description	Spec Code	Quantity			
				'17	'18		
				HHF	HJF		
36041	36041-0031-17L	COVER-TAIL,LH,C.B.ORANGE		1			
36041A	36041-0031-36S	COVER-TAIL,LH,P.S.GRAY			1		
36041B	36041-0031-60R	COVER-TAIL,LH,E.B.GREEN			1		
36041C	36041-0031-660	COVER-TAIL,LH,M.S.BLACK		1			
36041D	36041-0032-17L	COVER-TAIL,RH,C.B.ORANGE		1			
36041E	36041-0032-36S	COVER-TAIL,RH,P.S.GRAY			1		
36041F	36041-0032-60R	COVER-TAIL,RH,E.B.GREEN			1		
36041G	36041-0032-660	COVER-TAIL,RH,M.S.BLACK		1			
39156	39156-1751	PAD,20X30X6		2	2		
39156A	39156-2163	PAD,20X50X8		2	2		
92154	92154-0917	BOLT,SOCKET,5X12		4	4		
92160	92160-1613	DAMPER		2	2		
92161	92161-0266	DAMPER		2	2		
92200	92200-1820	WASHER,5.2X10X1.0		4	4		

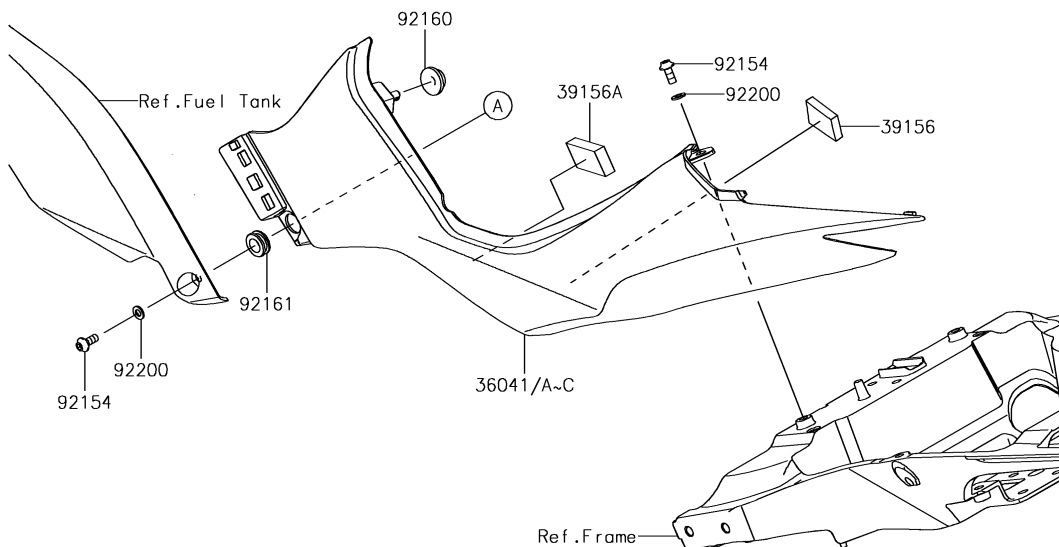

F2710

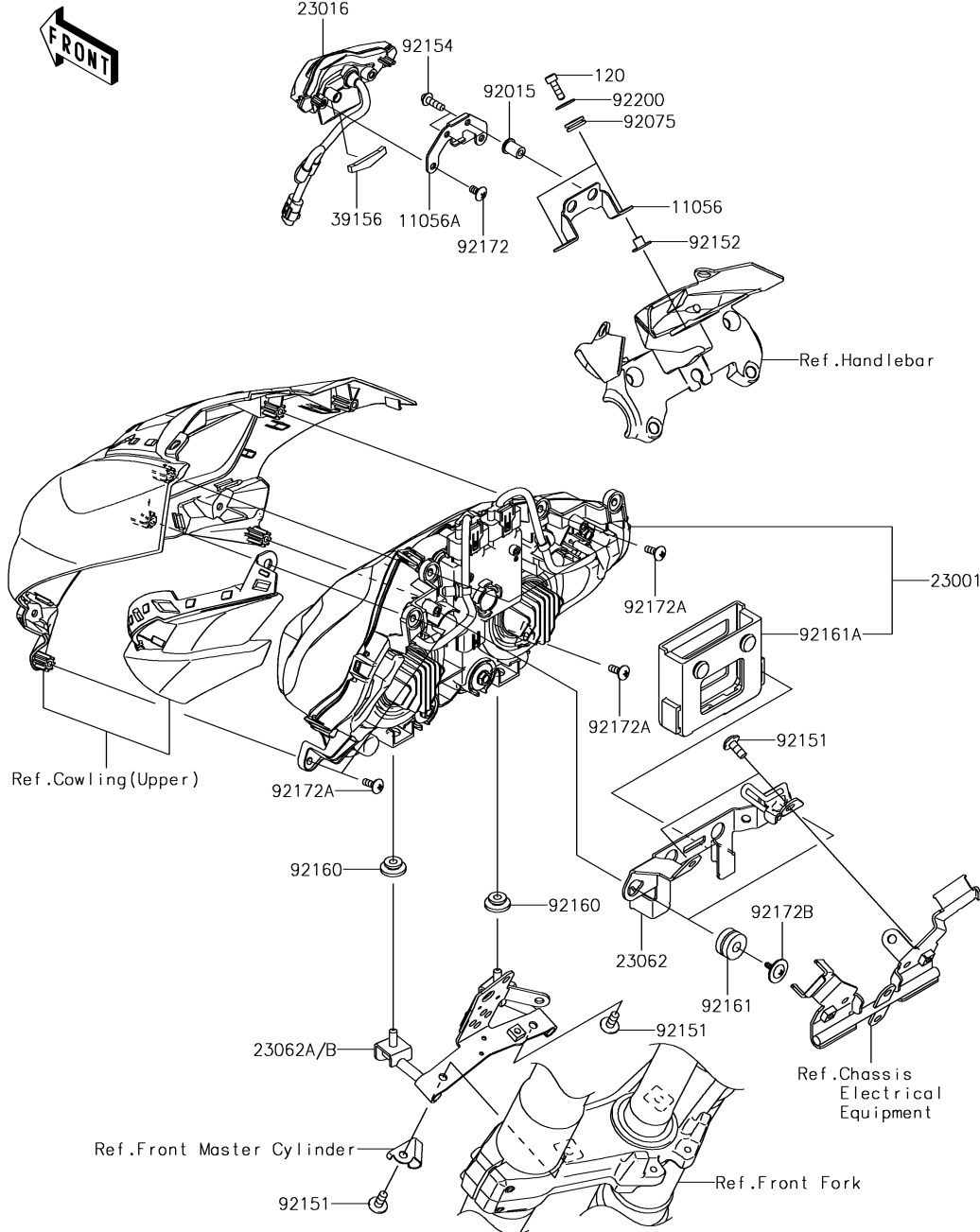

53. Headlight(s)

Ref. No.	Part No.	Description	Spec Code	Quantity			
				'17	'18		
				HHF	HJF		
11056	11056-2522	BRACKET,POSITION LAMP,FRM		1	1		
11056A	11056-2686	BRACKET,POSITION LAMP,LAMP		1	1		
23001	23001-0043	LAMP-ASSY-HEAD		1	1		
23016	23016-0570	LAMP-ASSY,POSITION		1	1		
23062	23062-0789	BRACKET-COMP,H.LAMP,UPP		1	1		
23062A	23062-0790	BRACKET-COMP,H.LAMP,LWR		1			
23062B	23062-0977	BRACKET-COMP,H.LAMP,LWR			1		
39156	39156-1799	PAD,POSITION LAMP		1	1		
92015	92015-1757	NUT,WELL,5MM		2	2		
92075	92075-161	DAMPER		2	2		
92151	92151-1654	BOLT,SOCKET,6X14		4	4		
92152	92152-1880	COLLAR,5,2X7.5X8.2		2	2		
92154	92154-0209	BOLT,SOCKET,5X16		2	2		
92160	92160-1613	DAMPER		2	2		
92161	92161-0054	DAMPER		2	2		
92161A	92161-1561	DAMPER,ECU		1	1		
92172	92172-0262	SCREW,TAPPING,5X10		2	2		
92172A	92172-0265	SCREW,TAPPING,5X14		6	6		
92172B	92172-0477	SCREW,TAPPING+PW,5X14		2	2		
92200	92200-0288	WASHER		2	2		
120	120CA0516	BOLT-SOCKET,5X16		2	2		

54. Taillight(s)



F2720

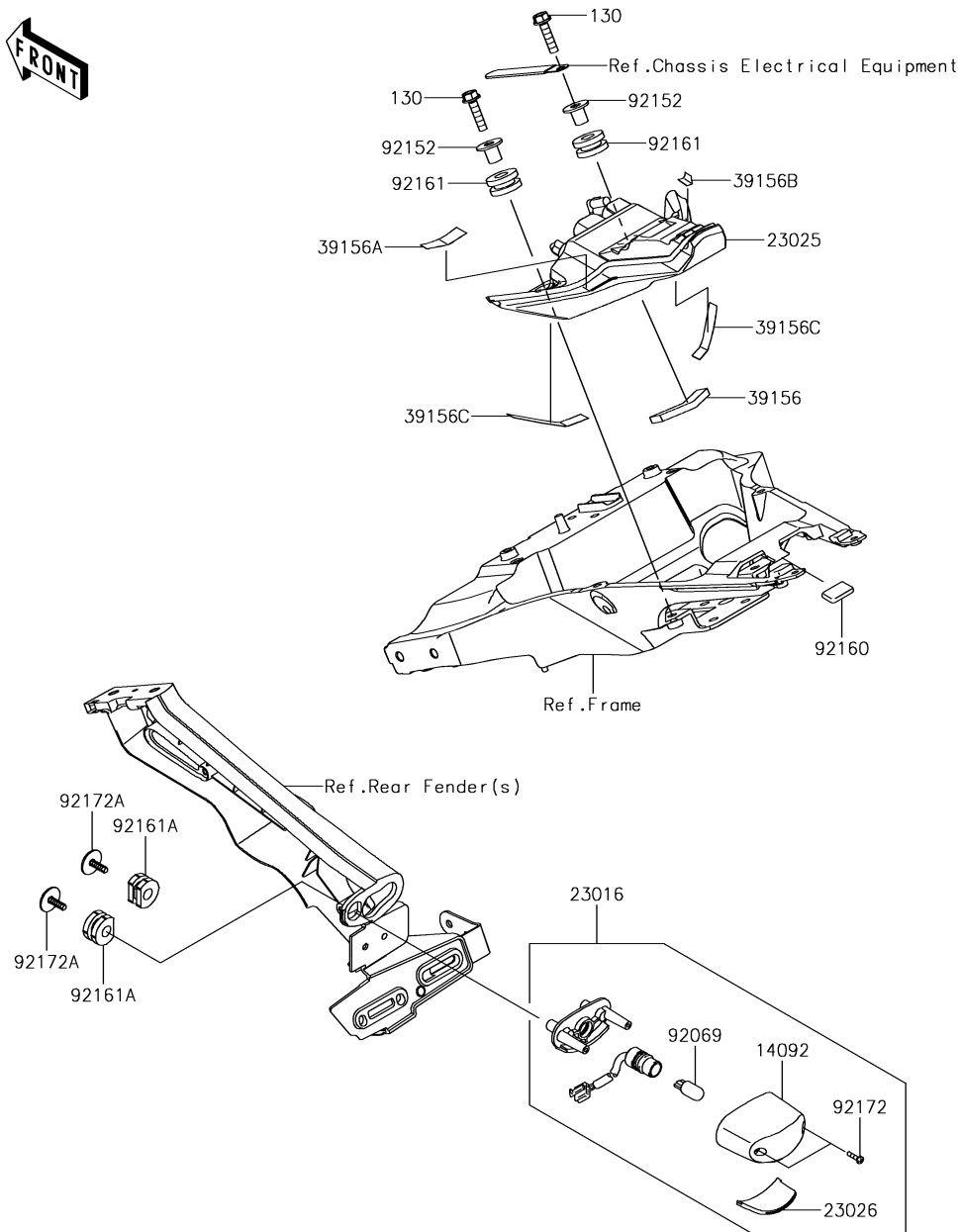

Ref. No.	Part No.	Description	Spec Code	Quantity			
				'17	'18		
				HHF	HJF		
14092	14092-0001	COVER,LICENSE LAMP		1	1		
23016	23016-0605	LAMP-ASSY,LICENCE		1	1		
23025	23025-0332	LAMP-TAIL,LED		1	1		
23026	23026-0028	LENS,LICENCE LAMP		1	1		
39156	39156-1746	PAD,TAIL LAMP		1	1		
39156A	39156-1790	PAD,TAIL LAMP,LH		1	1		
39156B	39156-1791	PAD,TAIL LAMP,RH		1	1		
39156C	39156-1797	PAD,TAIL LAMP,8X60		2	2		
92069	92069-1016	BULB,12V 5W		1	1		
92152	92152-0666	COLLAR		2	2		
92160	92160-1190	DAMPER		1	1		
92161	92161-0163	DAMPER		2	2		
92161A	92161-0776	DAMPER		2	2		
92172	92172-0343	SCREW,TAPPING,2.9X13		2	2		
92172A	92172-0481	SCREW,TAPTITE,5X16		2	2		
130	130BA0625	BOLT-FLANGED,6X25		2	2		

55. Turn Signals(HHF)

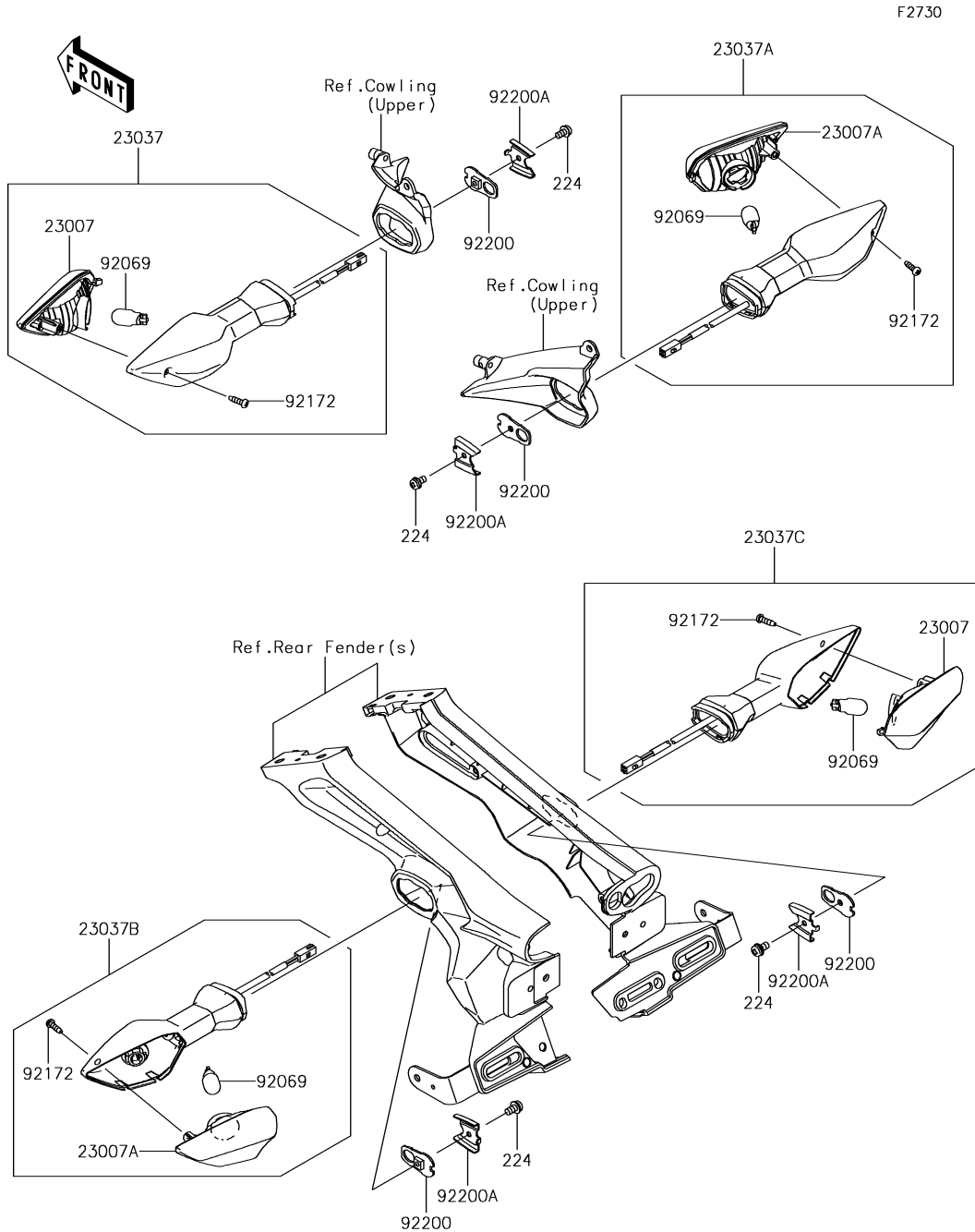

F2730

Ref. No.	Part No.	Description	Spec Code	Quantity			
				'17	'18		
				HHF	HJF		
23007	23007-0205	LENS-COMP		2			
23007A	23007-0206	LENS-COMP		2			
23037	23037-0330	LAMP-ASSY-SIGNAL,FR,LH		1			
23037A	23037-0331	LAMP-ASSY-SIGNAL,FR,RH		1			
23037B	23037-0342	LAMP-ASSY-SIGNAL,RR,LH		1			
23037C	23037-0343	LAMP-ASSY-SIGNAL,RR,RH		1			
92069	92069-0090	BULB,12V 10W		4			
92172	92172-1117	SCREW,4X14		4			
92200	92200-0854	WASHER,NUT 4MM		4			
92200A	92200-0855	WASHER		4			
224	224AB0408	SCREW-PAN-WP-CROS,4X8		4			

F2730A

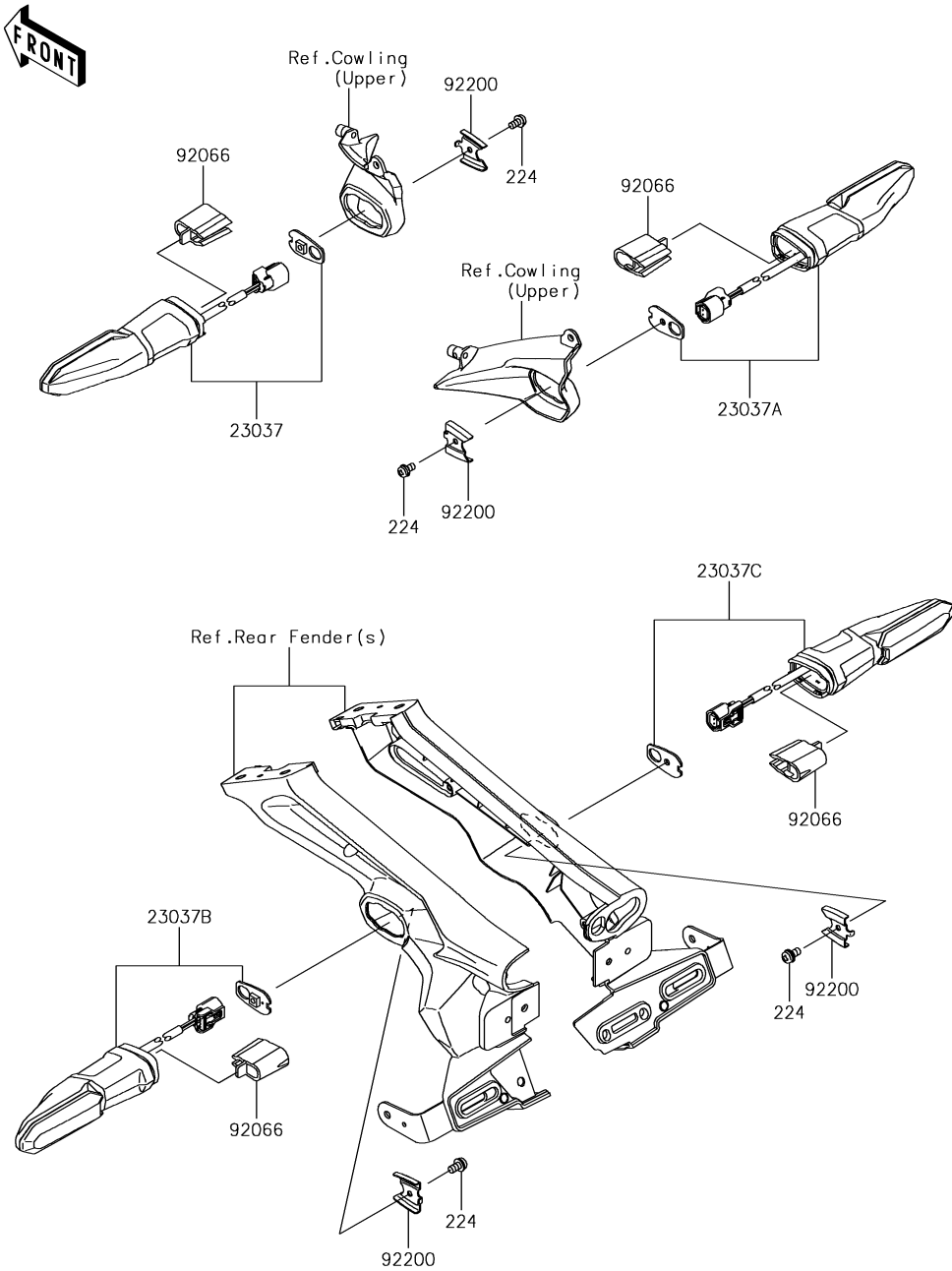

56. Turn Signals(HJF)

Ref. No.	Part No.	Description	Spec Code	Quantity			
				'17	'18		
				HHF	HJF		
23037	23037-0356	LAMP-ASSY-SIGNAL,LED,FR,LH			1		
23037A	23037-0357	LAMP-ASSY-SIGNAL,LED,FR,RH			1		
23037B	23037-0358	LAMP-ASSY-SIGNAL,LED,RR,LH			1		
23037C	23037-0359	LAMP-ASSY-SIGNAL,LED,RR,RH			1		
92066	92066-0919	PLUG,SIGNAL LAMP			4		
92200	92200-0855	WASHER			4		
224	224AB0408	SCREW-PAN-WP-CROS,4X8			4		

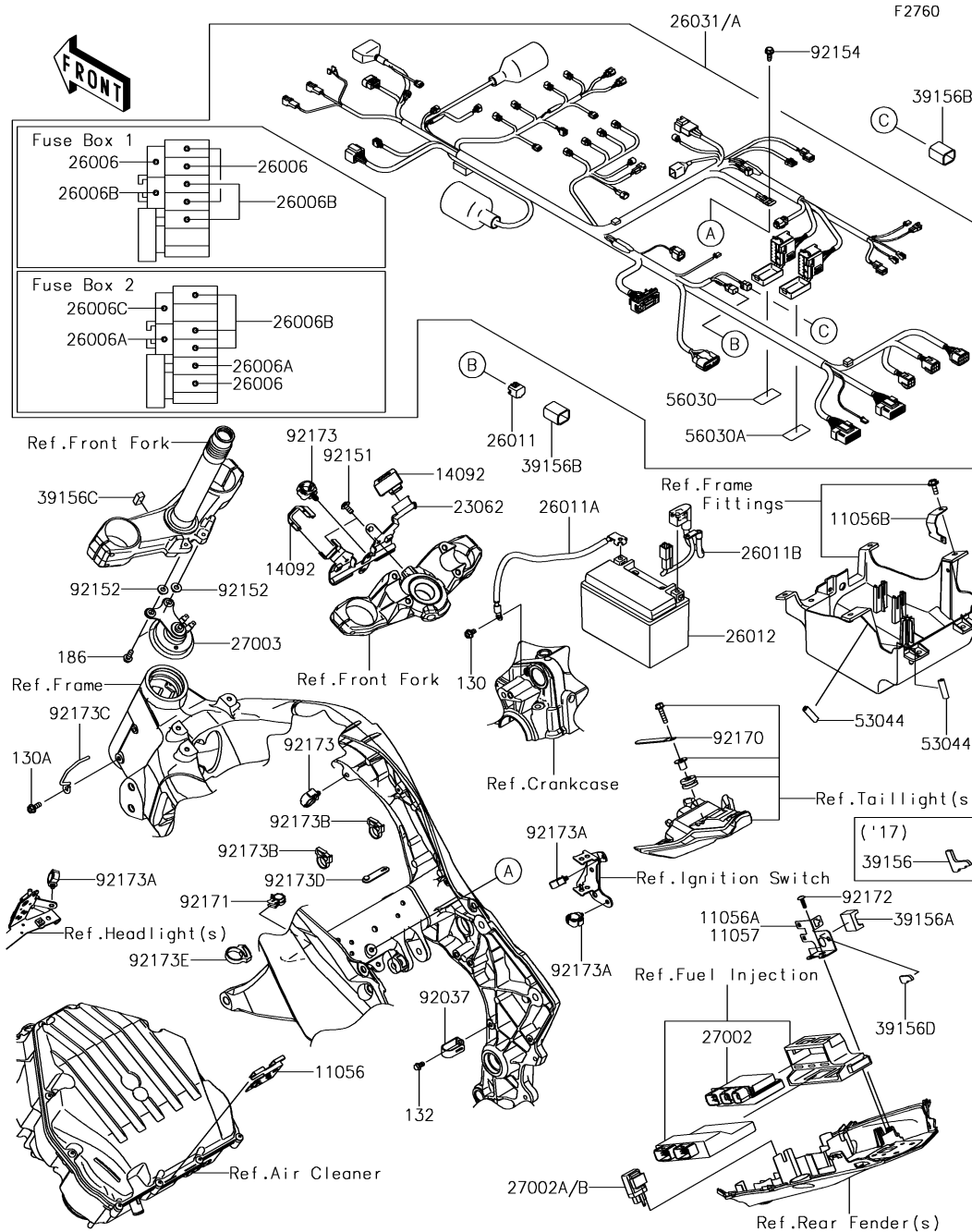

57. Chassis Electrical Equipment

Ref. No.	Part No.	Description	Spec Code	Quantity			
				'17	'18		
				HHF	HJF		
11056	11056-2434	BRACKET,SPEED SENSOR		1	1		
11056A	11056-2531	BRACKET,RR COUPLER		1			
11056B	11056-3936	BRACKET,PUMP COUPLER		1	1		
11057	11057-1334	BRACKET,REAR PARTS COUPLERS			1		
14092	14092-1166	COVER,HARNESS		2	2		
23062	23062-0819	BRACKET-COMP,HARNESS&CABLE		1	1		
26006	26006-0001	FUSE,MINI BLADE,15A,BLUE		5	5		
26006A	26006-0020	FUSE,MINI BLADE,25A,NATURAL		2	2		
26006B	26006-0055	FUSE,MINI BLADE,7.5A,BROWN		6	6		
26006C	26006-1080	FUSE,MINI BLADE,30A,GREEN		1	1		
26011	26011-0275	WIRE-LEAD,CONNECTOR COVER		1	1		
26011A	26011-0822	WIRE-LEAD,BATTERY(-)		1	1		
26011B	26011-0839	WIRE-LEAD,BATTERY(+)		1	1		
26012	26012-0709	BATTERY,YTX9-BS,12V 8AH		1	1		
26031	26031-2162	HARNESS,MAIN		1			
26031A	26031-2338	HARNESS,MAIN			1		
27002	27002-0025	RELAY-ASSY,BOX		1	1		
27002A	27002-0029	RELAY-ASSY,SIGNAL LAMP			1		
27002B	27002-1097	RELAY-ASSY,SIGNAL LAMP		1			
27003	27003-0096	HORN		1	1		
39156	39156-1803	PAD		1			
39156A	39156-1804	PAD		1	1		
39156B	39156-1886	PAD,DIAG. CONNECTOR		2	2		
39156C	39156-1968	PAD,20X8X10		1	1		
39156D	39156-2234	PAD,13X27X4			1		
53044	53044-0001	TRIM,L=30		2	2		
56030	56030-0830	LABEL,FUSE BOX1		1	1		
56030A	56030-0857	LABEL,FUSE BOX2		1	1		
92037	92037-2014	CLAMP,CABLE,STEEL SHEET		1	1		
92151	92151-1654	BOLT,SOCKET,6X14		2	2		
92152	92152-0286	COLLAR,6.3X8.3X16		2	2		
92154	92154-0551	BOLT,FLANGED,6X16		1	1		
92170	92170-1925	CLAMP		1	1		
92171	92171-1722	CLAMP,EDGE CLIP		1	1		
92172	92172-0238	SCREW,TAPPING,5X16		2	2		
92173	92173-0861	CLAMP		2	2		
92173A	92173-0868	CLAMP,HOLDER CLIP		3	3		
92173B	92173-0970	CLAMP,SNAPPER		2	2		
92173C	92173-1199	CLAMP,IRON WIRE		1	1		
92173D	92173-1229	CLAMP,RUBBER PLATE		1	1		

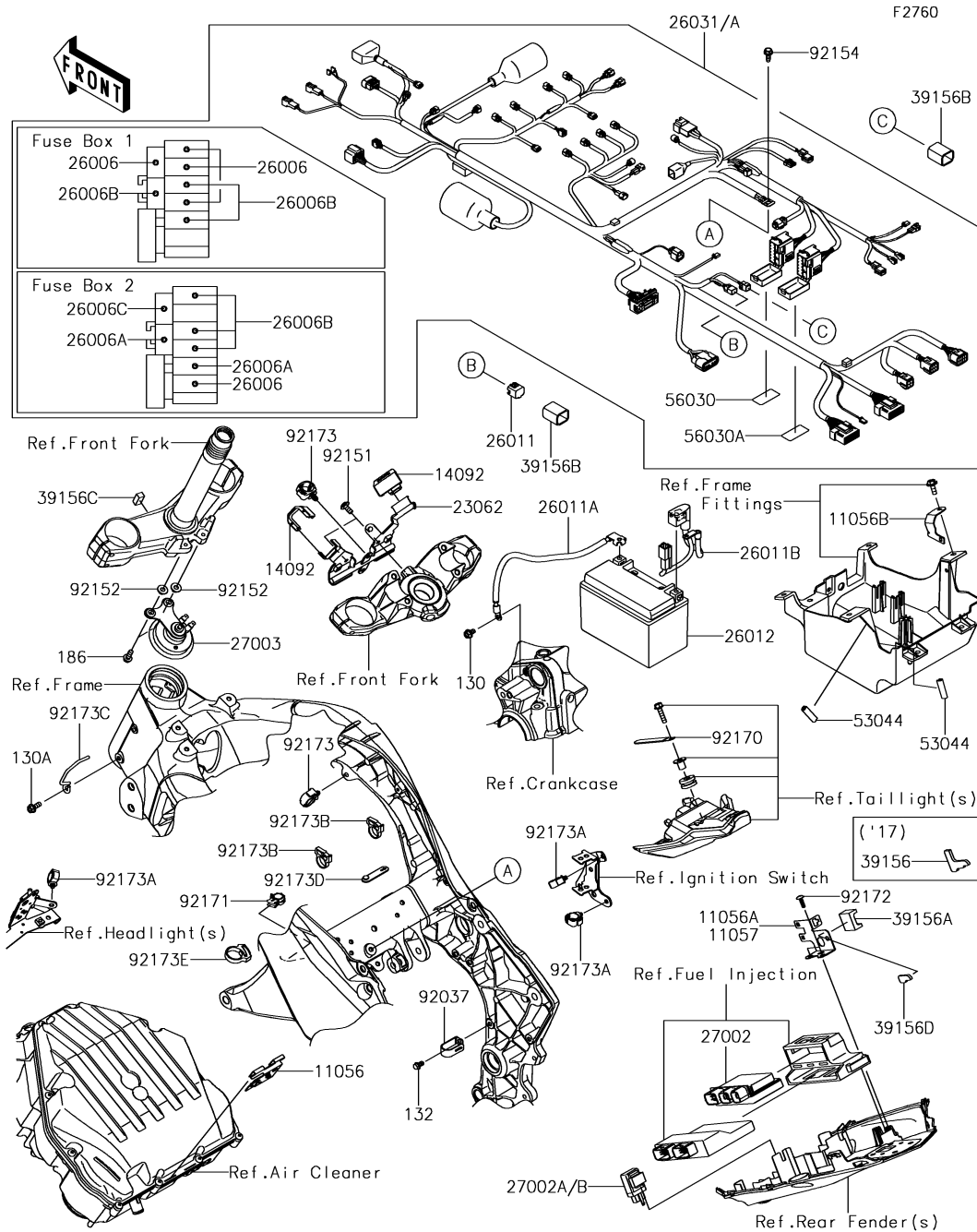

Ref. No.	Part No.	Description	Spec Code	Quantity			
				'17	'18		
92173E	92173-1632	CLAMP,SNP-22-0W		1	1		
130	130BA0610	BOLT-FLANGED,6X10		1	1		
130A	130BB0616	BOLT-FLANGED,6X16		1	1		
132	132BA0610	BOLT-FLANGED-SMALL,6X10		1	1		
186	186BB0618	BOLT-UPSET-WP,6X18		2	2		

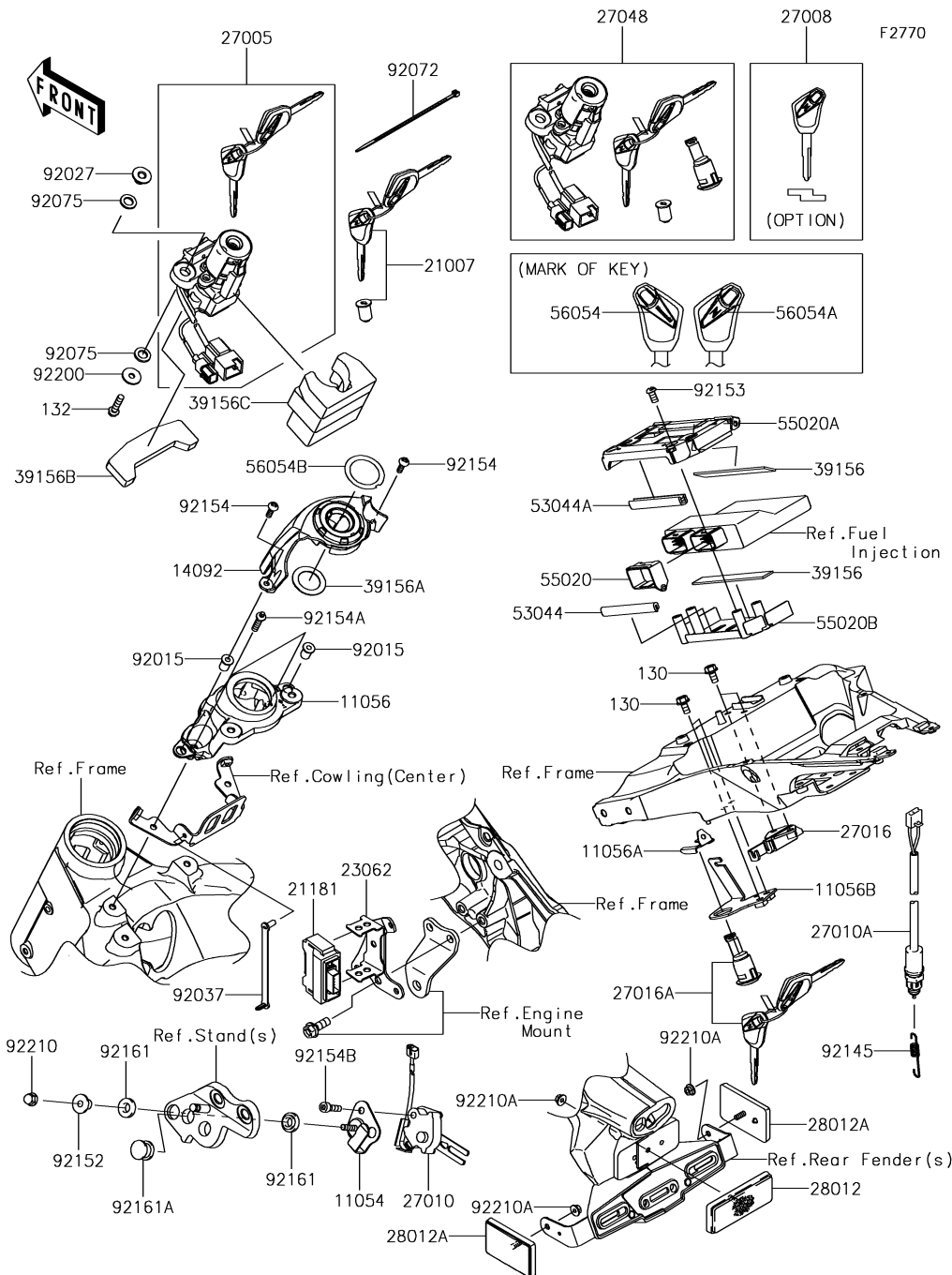

58. Ignition Switch

Ref. No.	Part No.	Description	Spec Code	Quantity			
				'17	'18		
				HHF	HJF		
11054	11054-1904	BRACKET,SIDE STAND SWITCH	1	1			
11056	11056-0161	BRACKET,IGNITION SWITCH	1	1			
11056A	11056-1084	BRACKET	1	1			
11056B	11056-2507	BRACKET,KEY CYLINDER	1	1			
14092	14092-1130	COVER,KEY CYLINDER	1	1			
21007	21007-5078	ROTOR,LOCK,TANK CAP	1	1			
21181	21181-0010	AMPLIFIER,IMMOBI	1	1			
23062	23062-0801	BRACKET-COMP,IMMOBI AMP	1	1			
27005	27005-0601	SWITCH-ASSY-IGNITION	1	1			
27008	27008-0601	KEY-LOCK,BLANK,IMMOBI (OPTION)	1	1			
27010	27010-0112	SWITCH,SIDE STAND	1	1			
27010A	27010-0749	SWITCH,STOP	1	1			
27016	27016-1115	LOCK-ASSY,SEAT STRIKER	1	1			
27016A	27016-5388	LOCK-ASSY,SEAT	1	1			
27048	27048-5080	SWITCH-ASSY	1	1			
28012	28012-1077	REFLECTOR-REFLEX	1	1			
28012A	28012-1088	REFLECTOR-REFLEX	2	2			
39156	39156-0096	PAD,15X120X2	2	2			
39156A	39156-0617	PAD	1	1			
39156B	39156-1754	PAD,FRAME	1	1			
39156C	39156-1755	PAD,IG. SWITCH	1	1			
53044	53044-0033	TRIM,L=90	1	1			
53044A	53044-0561	TRIM,L=85	1	1			
55020	55020-0782	GUARD,ECU CONNECTOR	1	1			
55020A	55020-0999	GUARD,ECU,UPP	1	1			
55020B	55020-1000	GUARD,ECU,LWR	1	1			
56054	56054-1572	MARK,KAWASAKI	AR	AR			
56054A	56054-1573	MARK,Z	AR	AR			
56054B	56054-1975	MARK,IG. SWITCH	1	1			
92015	92015-1757	NUT,WELL,5MM	2	2			
92027	92027-1045	COLLAR,L=9.6	2	2			
92037	92037-1903	CLAMP,SPEED,L=80.5	1	1			
92072	92072-3768	BAND,L=148	1	1			
92075	92075-1564	DAMPER	4	4			
92145	92145-0761	SPRING,BRAKE LAMP SWITCH	1	1			
92152	92152-1074	COLLAR	1	1			
92153	92153-0906	BOLT,6X12	4	4			
92154	92154-0209	BOLT,SOCKET,5X16	2	2			
92154A	92154-1858	BOLT,TORX,6X22	2	2			

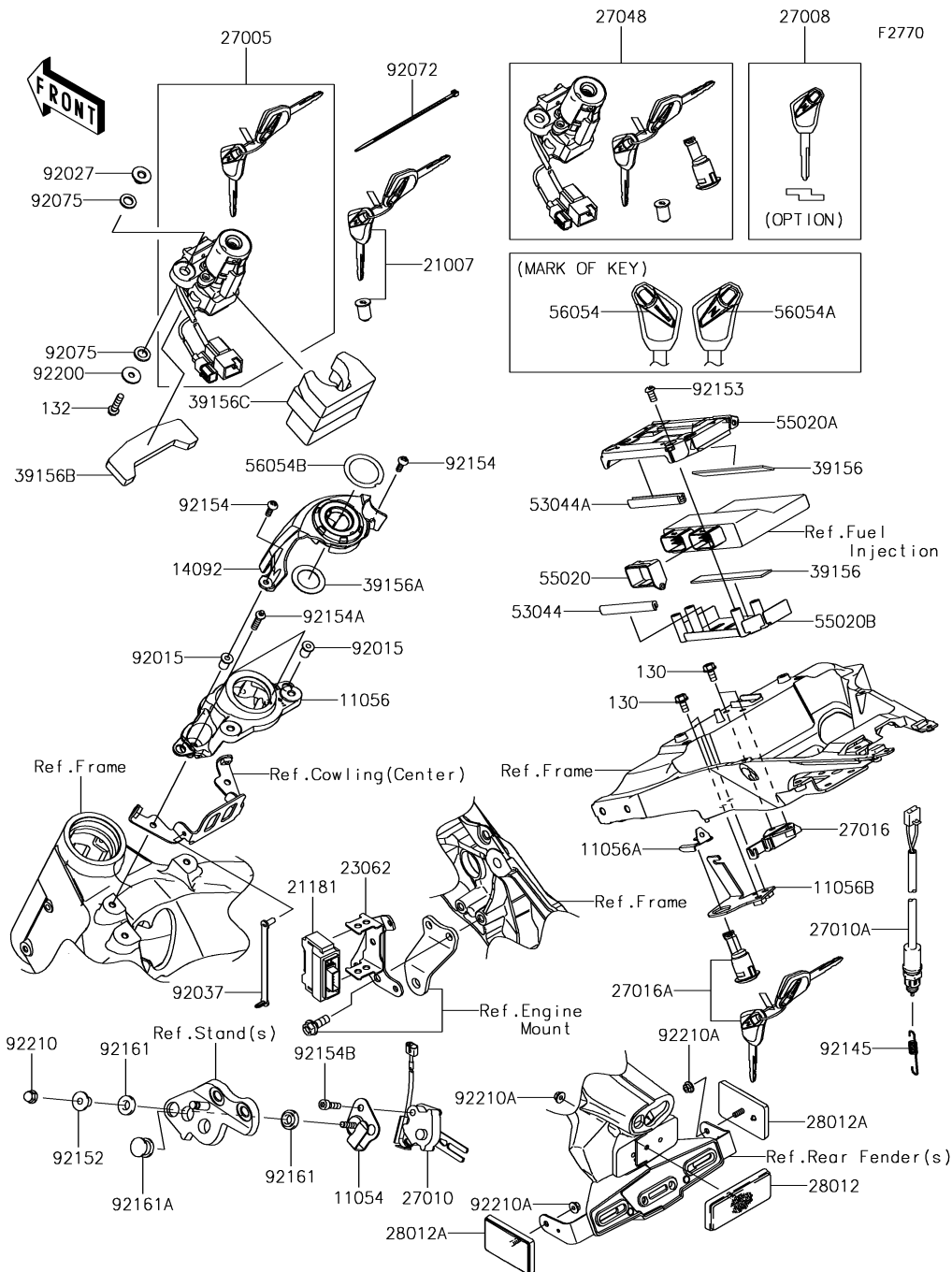

Ref. No.	Part No.	Description	Spec Code	Quantity			
				'17	'18		
				HHF	HJF		
92154B	92154-1898	BOLT, SOCKET, 6X22		1	1		
92161	92161-0117	DAMPER		2	2		
92161A	92161-0118	DAMPER		1	1		
92200	92200-0212	WASHER, 6X20X1.6		2	2		
92210	92210-0003	NUT, CAP, 6MM		1	1		
92210A	92210-0007	NUT, FLANGED, 5MM		3	3		
130	130BA0612	BOLT-FLANGED, 6X12		4	4		
132	132BA0625	BOLT-FLANGED-SMALL, 6X25		2	2		

F2810

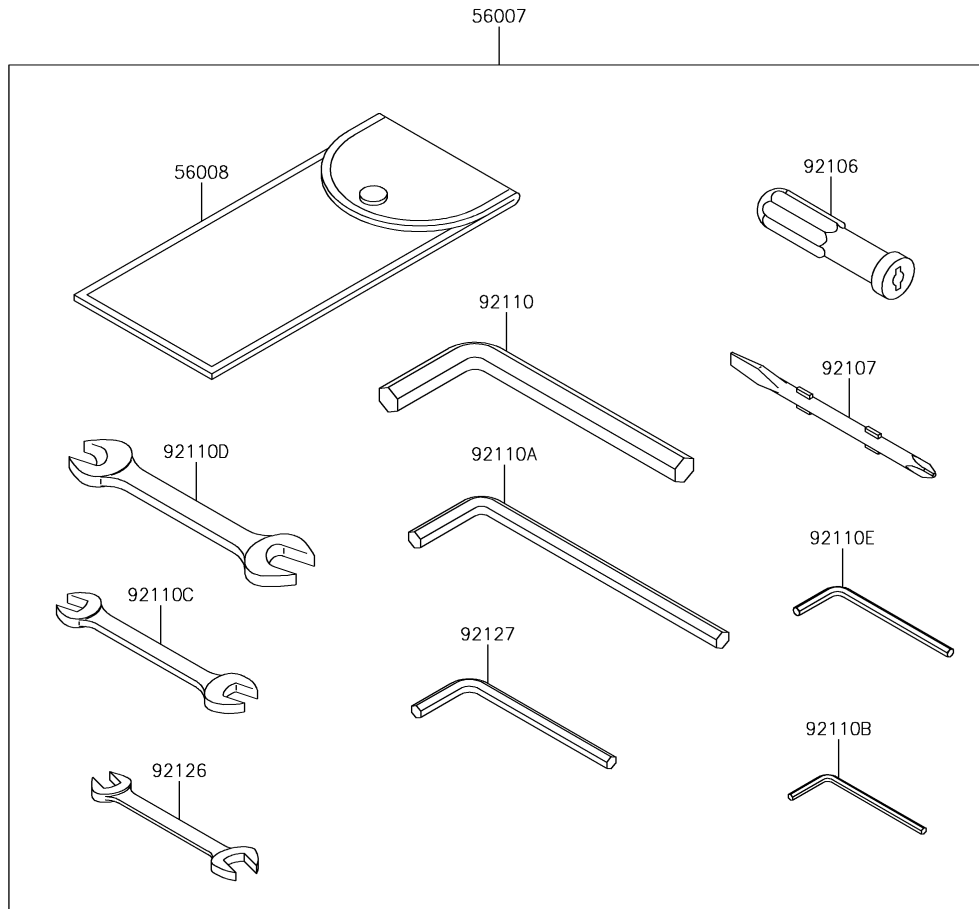

59. Owner's Tools

Ref. No.	Part No.	Description	Spec Code	Quantity			
				'17	'18		
				HHF	HJF		
56007	56007-0153	TOOL-KIT		1	1		
56008	56008-0570	BAG,TOOL		1	1		
92104	92104-0004	GASKET-LIQUID,TB1211F,CLEAR		1	1		
92104A	92104-1064	GASKET-LIQUID,TB1216B,BLACK		1	1		
92104B	92104-2068	GASKET-LIQUID,TB1207B,BLACK		1	1		
92106	92106-1001	GRIP-SCREW DRIVER		1	1		
92107	92107-1051	TOOL-DRIVER,#2PHILLIPS&SLOT		1	1		
92110	92110-1104	TOOL-WRENCH,ALLEN,12MM		1	1		
92110A	92110-1108	TOOL-WRENCH,ALLEN,8MM		1	1		
92110B	92110-1140	TOOL-WRENCH,ALLEN,3MM		1	1		
92110C	92110-1152	TOOL-WRENCH,OPEN END,10X12		1	1		
92110D	92110-1153	TOOL-WRENCH,OPEN END,14X17		1	1		
92110E	92110-3703	TOOL-WRENCH,ALLEN,4MM		1	1		
92126	92126-004	TOOL-WRENCH,OPEN END,8X10		1	1		
92127	92127-003	TOOL-WRENCH,ALLEN,6MM		1	1		

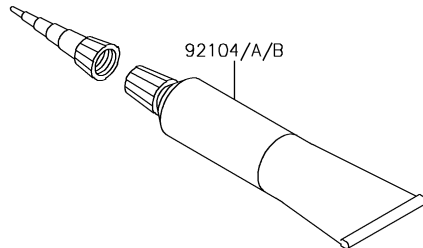

F2860

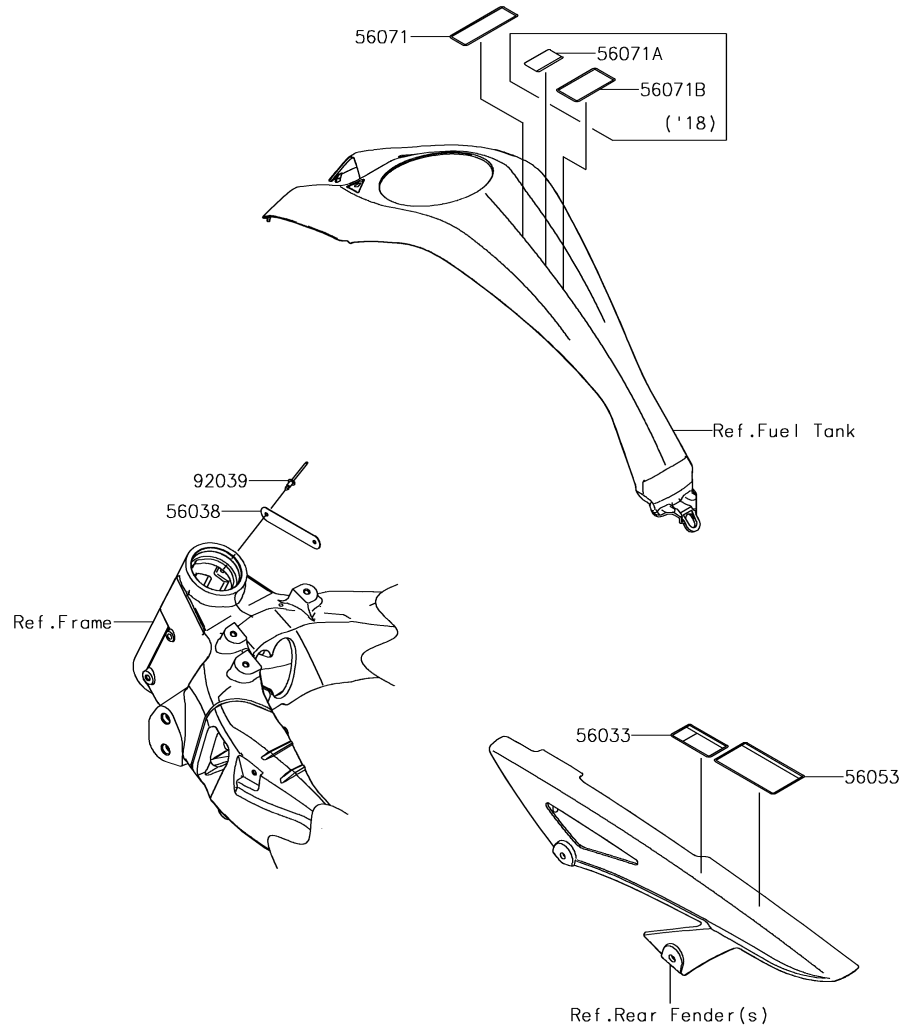

60. Labels

Ref. No.	Part No.	Description	Spec Code	Quantity			
				'17	'18		
				HHF	HJF		
56033	56033-0861	LABEL-MANUAL,CHAIN		1	1		
56038	56038-1054	LABEL-BRAND,KAWASAKI		1	1		
56053	56053-0935	LABEL-SPECIFICATION,TIRE&LOAD		1	1		
56071	56071-0316	LABEL-WARNING,HIGH-OCTANE		1	1		
56071A	56071-0694	LABEL-WARNING,FUEL,E5/E10					1
56071B	56071-0765	LABEL-WARNING,EVAPO					1
92039	92039-1251	RIVET		2	2		

F2861

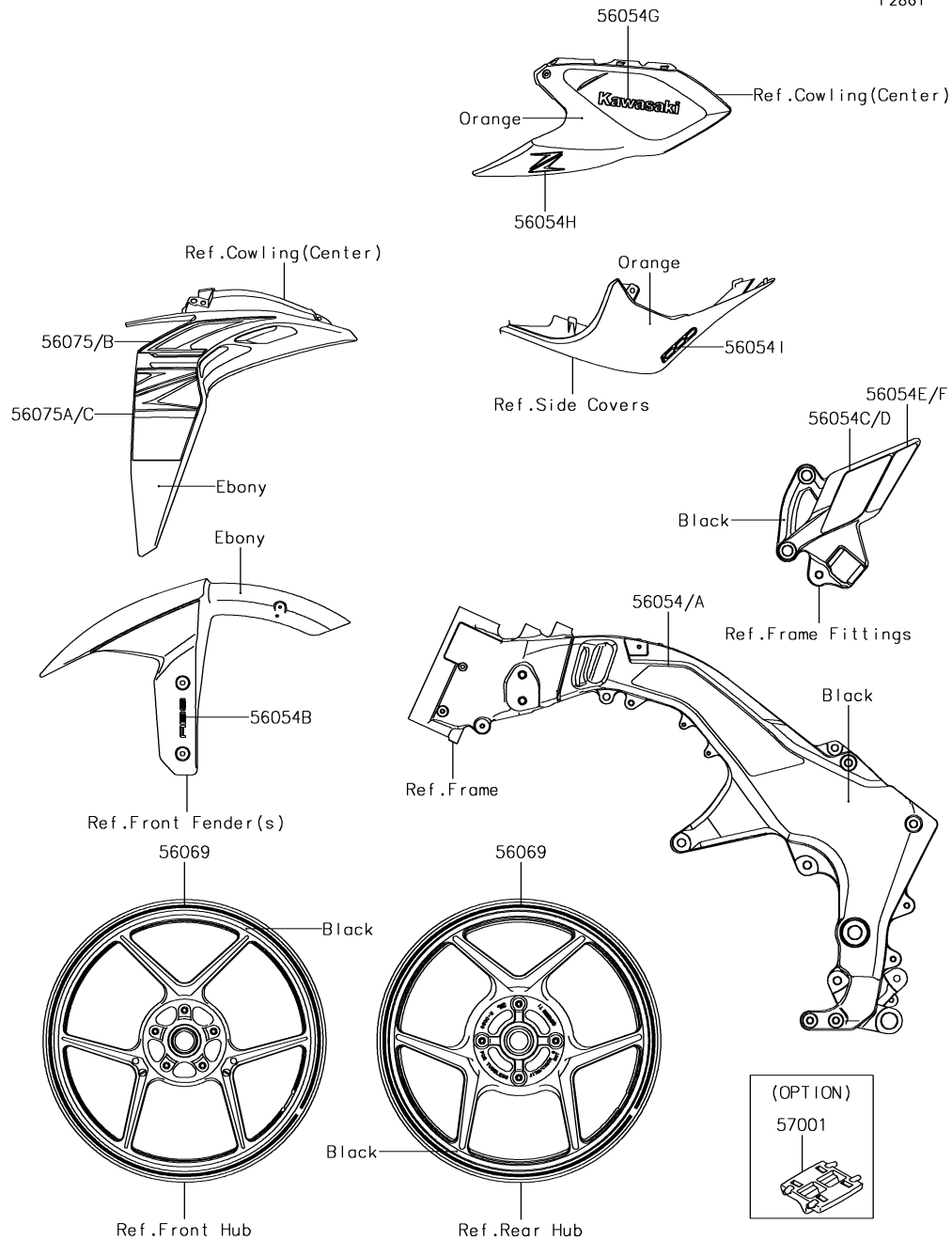

61. Decals(Orange)(HHF)

Ref. No.	Part No.	Description	Spec Code	Quantity			
				'17	'18		
				HHF	HJF		
56054	56054-0607	MARK,FRAME PAD,LH				1	
56054A	56054-0608	MARK,FRAME PAD,RH				1	
56054B	56054-0672	MARK,FR FENDER,ABS				2	
56054C	56054-1245	MARK,STEP STAY,LH				1	
56054D	56054-1246	MARK,STEP STAY,RH				1	
56054E	56054-1280	MARK,STEP STAY,LWR,LH				1	
56054F	56054-1281	MARK,STEP STAY,LWR,RH				1	
56054G	56054-1356	MARK,KAWASAKI				2	
56054H	56054-1914	MARK,DUCT COVER,Z				2	
56054I	56054-2171	MARK,TAIL COVER,1000				2	
56069	56069-1648	PATTERN,WHEEL,ORANGE				4	
56075	56075-2480	PATTERN,SHROUD,LH,UPP				1	
56075A	56075-2481	PATTERN,SHROUD,LH,LWR				1	
56075B	56075-2482	PATTERN,SHROUD,RH,UPP				1	
56075C	56075-2483	PATTERN,SHROUD,RH,LWR				1	
57001	57001-1752	RIM STRIPE APPLICATOR (OPTION)				AR	

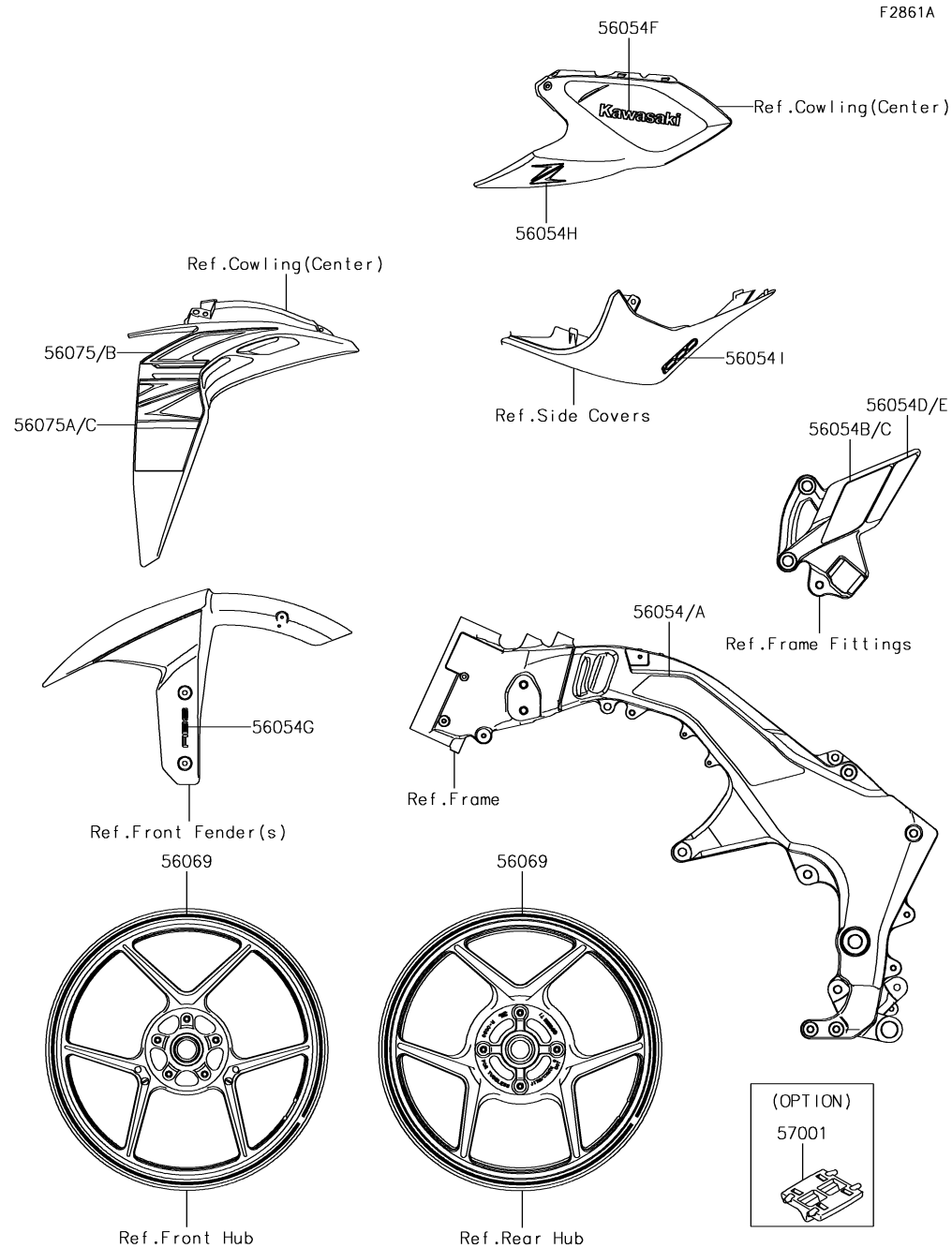

F2861A

62. Decals(Black)(HHF)

Ref. No.	Part No.	Description	Spec Code	Quantity			
				'17	'18		
				HHF	HJF		
56054	56054-0607	MARK,FRAME PAD,LH				1	
56054A	56054-0608	MARK,FRAME PAD,RH				1	
56054B	56054-1245	MARK,STEP STAY,LH				1	
56054C	56054-1246	MARK,STEP STAY,RH				1	
56054D	56054-1280	MARK,STEP STAY,LWR,LH				1	
56054E	56054-1281	MARK,STEP STAY,LWR,RH				1	
56054F	56054-1356	MARK,KAWASAKI				2	
56054G	56054-1370	MARK,FR FENDER,ABS				2	
56054H	56054-1914	MARK,DUCT COVER,Z				2	
56054I	56054-2170	MARK,TAIL COVER,1000				2	
56069	56069-2527	PATTERN,WHEEL,GRN,4X1353				4	
56075	56075-2474	PATTERN,SHROUD,LH,UPP				1	
56075A	56075-2475	PATTERN,SHROUD,LH,LWR				1	
56075B	56075-2476	PATTERN,SHROUD,RH,UPP				1	
56075C	56075-2477	PATTERN,SHROUD,RH,LWR				1	
57001	57001-1752	RIM STRIPE APPLICATOR (OPTION)				AR	

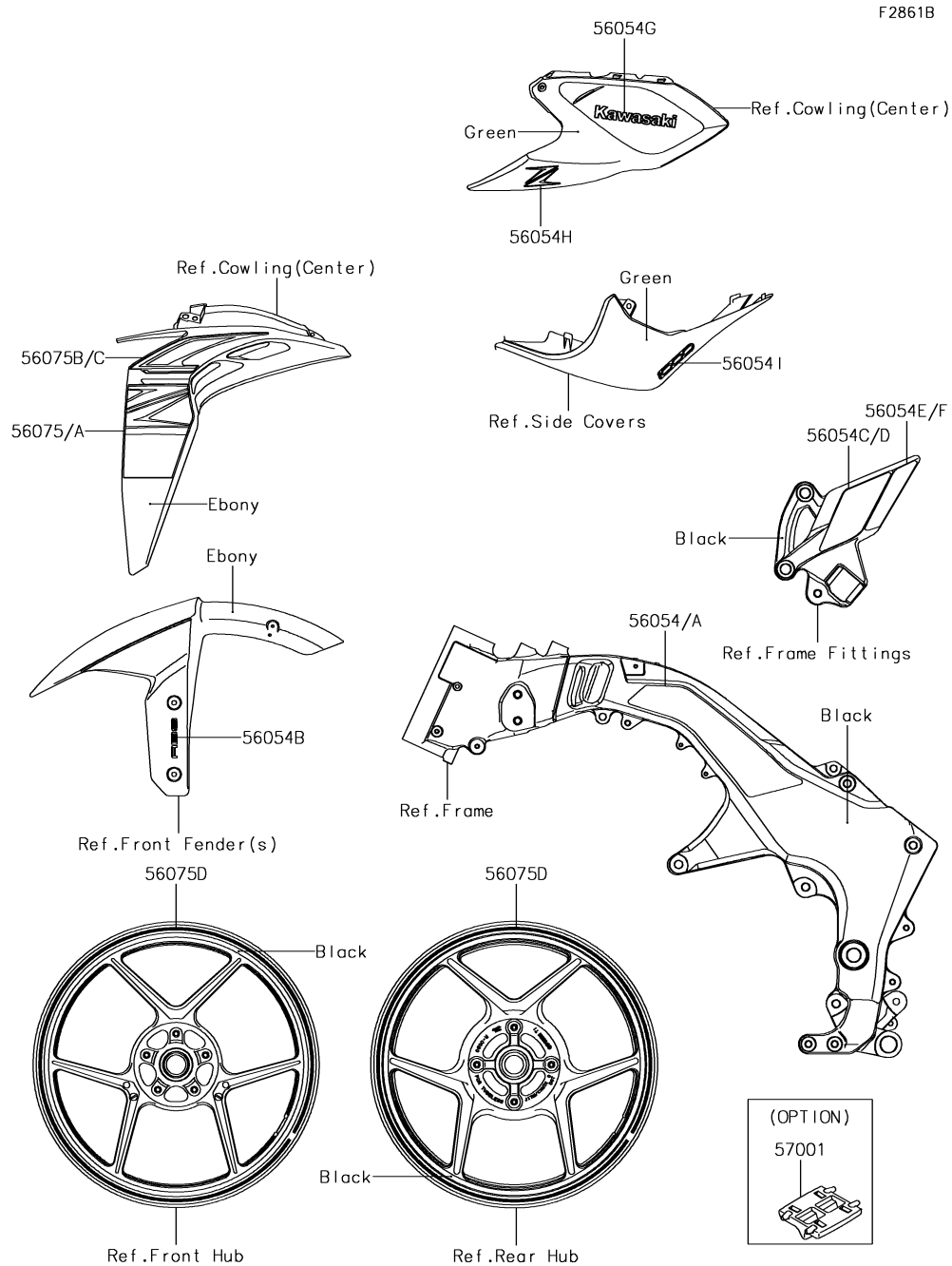

Ref. No.	Part No.	Description	Spec Code	Quantity			
				'17	'18		
				HHF	HJF		
56054	56054-0607	MARK,FRAME PAD,LH				1	
56054A	56054-0608	MARK,FRAME PAD,RH				1	
56054B	56054-0672	MARK,FR FENDER,ABS				2	
56054C	56054-1245	MARK,STEP STAY,LH				1	
56054D	56054-1246	MARK,STEP STAY,RH				1	
56054E	56054-1280	MARK,STEP STAY,LWR,LH				1	
56054F	56054-1281	MARK,STEP STAY,LWR,RH				1	
56054G	56054-1356	MARK,KAWASAKI				2	
56054H	56054-1914	MARK,DUCT COVER,Z				2	
56054I	56054-2171	MARK,TAIL COVER,1000				2	
56075	56075-2481	PATTERN,SHROUD,LH,LWR				1	
56075A	56075-2483	PATTERN,SHROUD,RH,LWR				1	
56075B	56075-4008	PATTERN,SHROUD,LH,UPP				1	
56075C	56075-4009	PATTERN,SHROUD,RH,UPP				1	
56075D	56075-4010	PATTERN,WHEEL,GREEN,4X1353				4	
57001	57001-1752	RIM STRIPE APPLICATOR (OPTION)				AR	

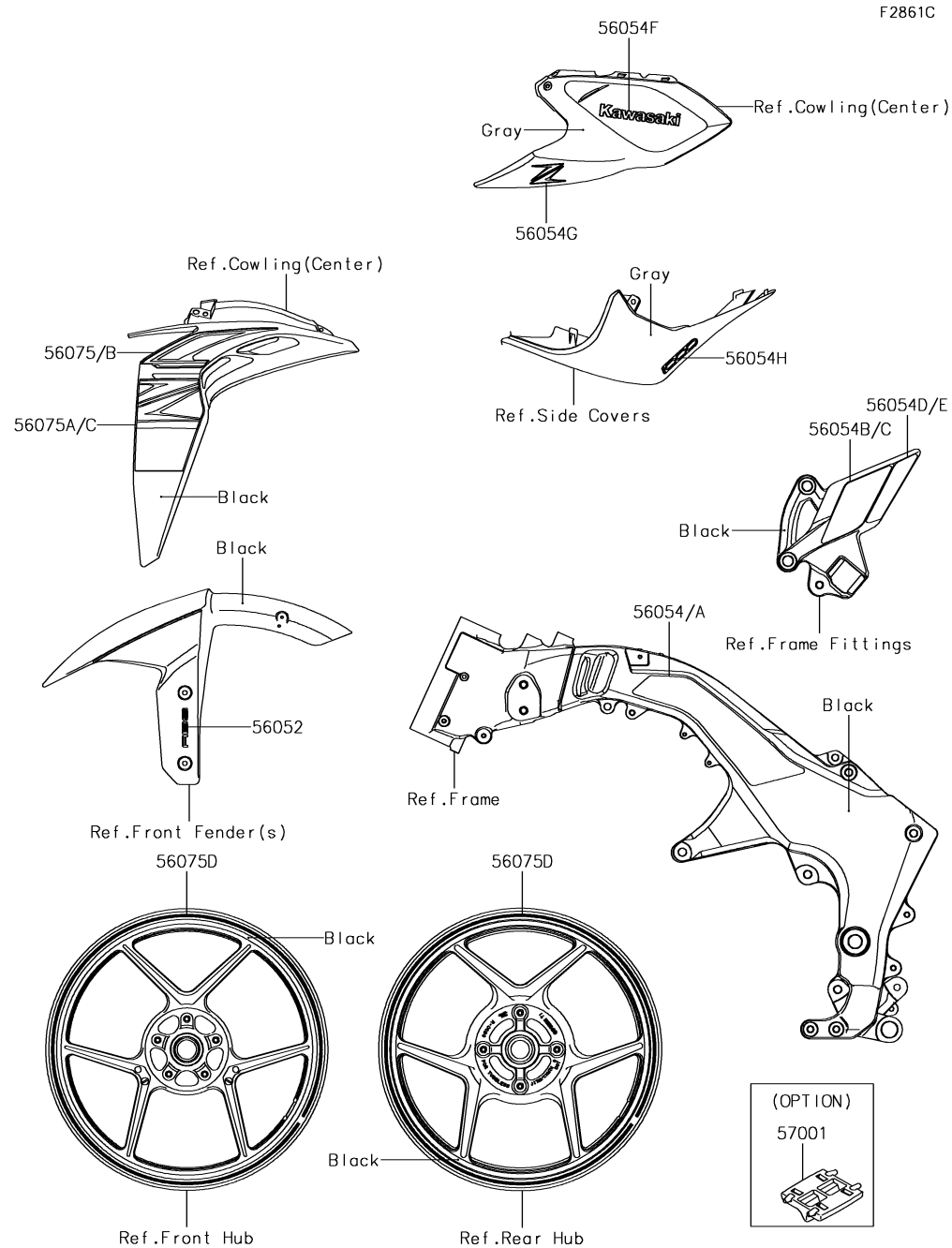

F2861C

64. Decals(Gray)(HJF)

Ref. No.	Part No.	Description	Spec Code	Quantity			
				'17	'18		
				HHF	HJF		
56052	56052-0869	MARK,FR FENDER,ABS			2		
56054	56054-0607	MARK,FRAME PAD,LH			1		
56054A	56054-0608	MARK,FRAME PAD,RH			1		
56054B	56054-1245	MARK,STEP STAY,LH			1		
56054C	56054-1246	MARK,STEP STAY,RH			1		
56054D	56054-1280	MARK,STEP STAY,LWR,LH			1		
56054E	56054-1281	MARK,STEP STAY,LWR,RH			1		
56054F	56054-1356	MARK,KAWASAKI			2		
56054G	56054-1914	MARK,DUCT COVER,Z			2		
56054H	56054-2343	MARK,TAIL COVER,1000			2		
56075	56075-4011	PATTERN,SHROUD,LH,UPP			1		
56075A	56075-4012	PATTERN,SHROUD,LH,LWR			1		
56075B	56075-4013	PATTERN,SHROUD,RH,UPP			1		
56075C	56075-4014	PATTERN,SHROUD,RH,LWR			1		
56075D	56075-4015	PATTERN,WHEEL,BLUE,4X1353			4		
57001	57001-1752	RIM STRIPE APPLICATOR (OPTION)				AR	

F2870

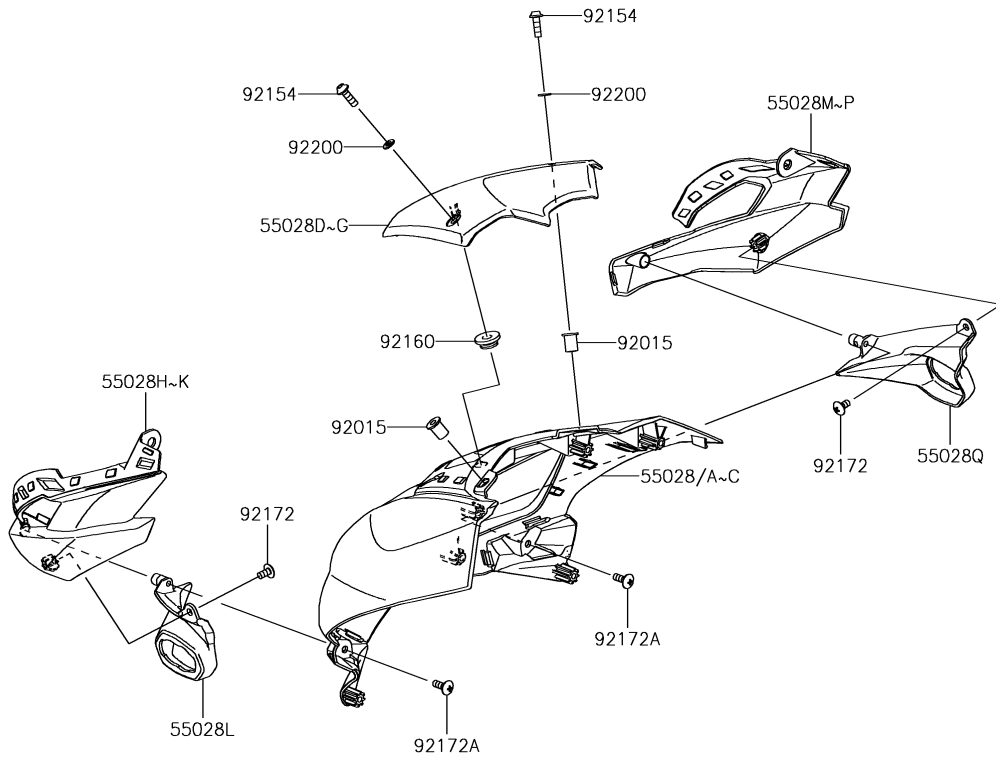

65. Cowling(Upper)

Ref. No.	Part No.	Description	Spec Code	Quantity			
				'17	'18		
				HHF	HJF		
55028	55028-0486-17L	COWLING,UPP,CNT,C.B.ORANGE		1			
55028A	55028-0486-36S	COWLING,UPP,CNT,P.S.GRAY			1		
55028B	55028-0486-45L	COWLING,UPP,CNT,F.EBONY			1		
55028C	55028-0486-660	COWLING,UPP,CNT,M.S.BLACK		1			
55028D	55028-0487-25V	COWLING,UPP,UPP,C.S.BLUE			1		
55028E	55028-0487-40R	COWLING,UPP,UPP,G.B.GREEN		1			
55028F	55028-0487-45L	COWLING,UPP,UPP,F.EBONY		1			
55028G	55028-0487-60R	COWLING,UPP,UPP,E.B.GREEN			1		
55028H	55028-0488-25V	COWLING,UPP,LH,C.S.BLUE			1		
55028I	55028-0488-45L	COWLING,UPP,LH,F.EBONY		1			
55028J	55028-0488-60R	COWLING,UPP,LH,E.B.GREEN			1		
55028K	55028-0488-660	COWLING,UPP,LH,M.S.BLACK		1			
55028L	55028-0489	COWLING,UPP,LH,SIGNAL		1	1		
55028M	55028-0490-25V	COWLING,UPP,RH,C.S.BLUE			1		
55028N	55028-0490-45L	COWLING,UPP,RH,F.EBONY		1			
55028O	55028-0490-60R	COWLING,UPP,RH,E.B.GREEN			1		
55028P	55028-0490-660	COWLING,UPP,RH,M.S.BLACK		1			
55028Q	55028-0491	COWLING,UPP,RH,SIGNAL		1	1		
92015	92015-1757	NUT,WELL,5MM		2	2		
92154	92154-0209	BOLT,SOCKET,5X16		2	2		
92160	92160-1613	DAMPER		1	1		
92172	92172-0262	SCREW,TAPPING,5X10		2	2		
92172A	92172-0265	SCREW,TAPPING,5X14		2	2		
92200	92200-1820	WASHER,5.2X10X1.0		2	2		

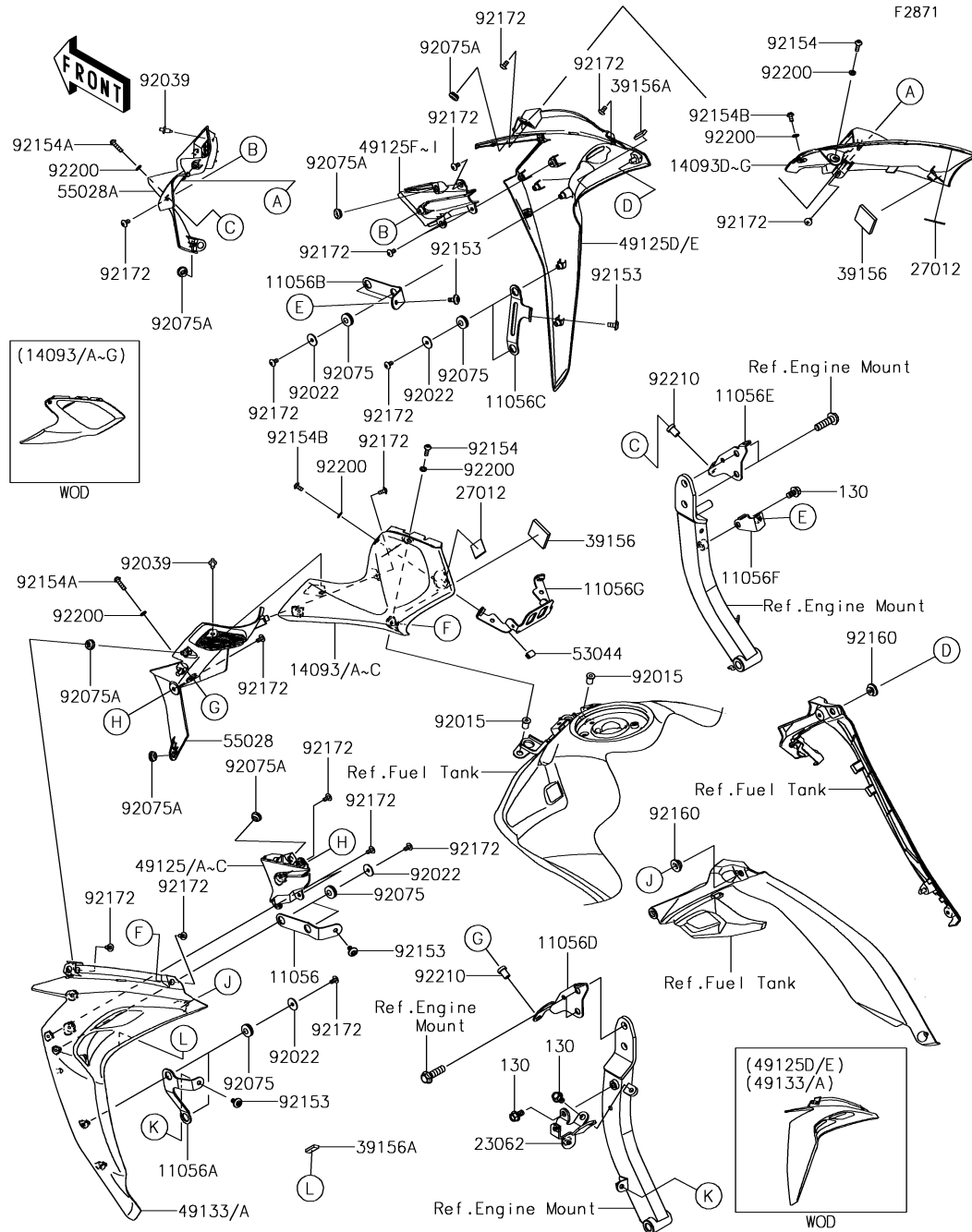

Ref. No.	Part No.	Description	Spec Code	Quantity			
				'17	'18		
				HHF	HJF		
11056	11056-2510	BRACKET,SHROUD,LH,UPP	1	1			
11056A	11056-2511	BRACKET,SHROUD,LH,LWR	1	1			
11056B	11056-2512	BRACKET,SHROUD,RH,UPP	1	1			
11056C	11056-2513	BRACKET,SHROUD,RH,LWR	1	1			
11056D	11056-2514	BRACKET,INNER COWL.,LH	1	1			
11056E	11056-2515	BRACKET,INNER COWL.,RH	1	1			
11056F	11056-2761	BRACKET	1	1			
11056G	11056-3933	BRACKET,IGNITION SW.	1	1			
14093	14093-0089-17L	COVER,DUCT,LH,C.B.ORANGE	1				
14093A	14093-0089-36S	COVER,DUCT,LH,P.S.GRAY		1			
14093B	14093-0089-60R	COVER,DUCT,LH,E.B.GREEN			1		
14093C	14093-0089-660	COVER,DUCT,LH,M.S.BLACK	1				
14093D	14093-0090-17L	COVER,DUCT,RH,C.B.ORANGE	1				
14093E	14093-0090-36S	COVER,DUCT,RH,P.S.GRAY			1		
14093F	14093-0090-60R	COVER,DUCT,RH,E.B.GREEN			1		
14093G	14093-0090-660	COVER,DUCT,RH,M.S.BLACK			1		
23062	23062-0788	BRACKET-COMP	1	1			
27012	27012-0776	HOOK,FASTENER,20X30	2	2			
39156	39156-1736	PAD,35X35X5	2	2			
39156A	39156-1792	PAD,8X30X4	2	2			
49125	49125-0575-17L	SHROUD,LH,SLAT,C.B.ORANGE	1				
49125A	49125-0575-25V	SHROUD,LH,SLAT,C.S.BLUE			1		
49125B	49125-0575-40R	SHROUD,LH,SLAT,G.B.GREEN	1				
49125C	49125-0575-60R	SHROUD,LH,SLAT,E.B.GREEN	1	1			
49125D	49125-0576-45L	SHROUD,RH,F.EBONY	1	1			
49125E	49125-0576-660	SHROUD,RH,M.S.BLACK	1	1			
49125F	49125-0577-17L	SHROUD,RH,SLAT,C.B.ORANGE	1				
49125G	49125-0577-25V	SHROUD,RH,SLAT,C.S.BLUE			1		
49125H	49125-0577-40R	SHROUD,RH,SLAT,G.B.GREEN	1				
49125I	49125-0577-60R	SHROUD,RH,SLAT,E.B.GREEN			1		
49133	49133-0017-45L	SHROUD,LH,F.EBONY	1	1			
49133A	49133-0017-660	SHROUD,LH,M.S.BLACK	1	1			
53044	53044-0577	TRIM	1	1			
55028	55028-0492	COWLING,INNER,LH	1	1			
55028A	55028-0493	COWLING,INNER,RH	1	1			
92015	92015-1757	NUT,WELL,5MM	2	2			
92022	92022-1405	WASHER,5.5X20X1.2	8	8			
92039	92039-0068	RIVET	2	2			
92075	92075-051	DAMPER	8	8			
92075A	92075-1011	DAMPER,6X16X7	6	6			

'17-'18 ZR1000 HHF/HJF

66-1. Cowling(Center)

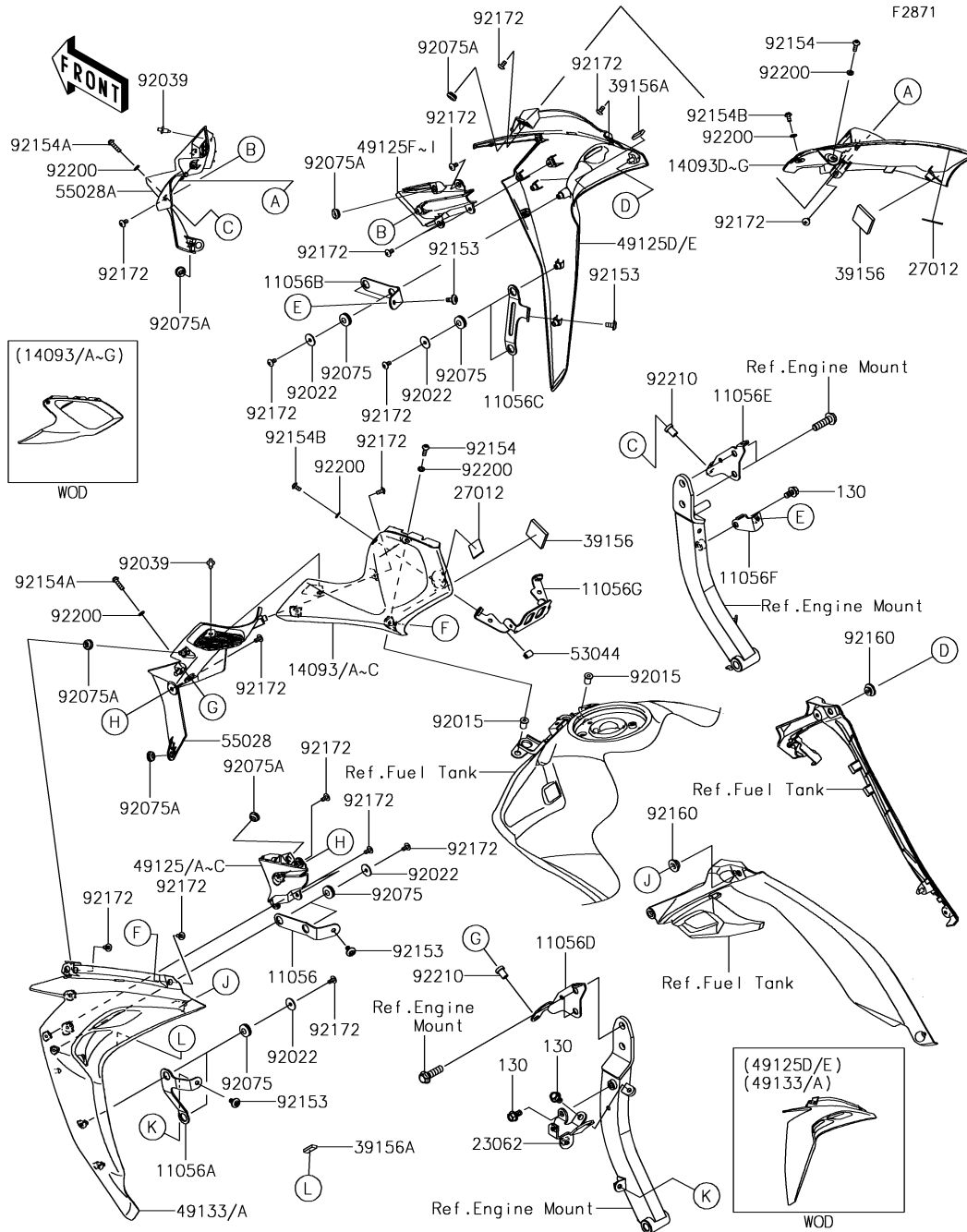

Ref. No.	Part No.	Description	Spec Code	Quantity			
				'17	'18		
				HHF	HJF		
92153	92153-1948	BOLT, SOCKET, 6X12	4	4			
92154	92154-0209	BOLT, SOCKET, 5X16	2	2			
92154A	92154-0210	BOLT, SOCKET, 5X20	2	2			
92154B	92154-0211	BOLT, SOCKET, 5X10	2	2			
92160	92160-1613	DAMPER	2	2			
92172	92172-0262	SCREW, TAPPING, 5X10	22	22			
92200	92200-1820	WASHER, 5.2X10X1.0	6	6			
92210	92210-0001	NUT, 5MM	2	2			
130	130BB0814	BOLT-FLANGED, 8X14	3	3			

F2872

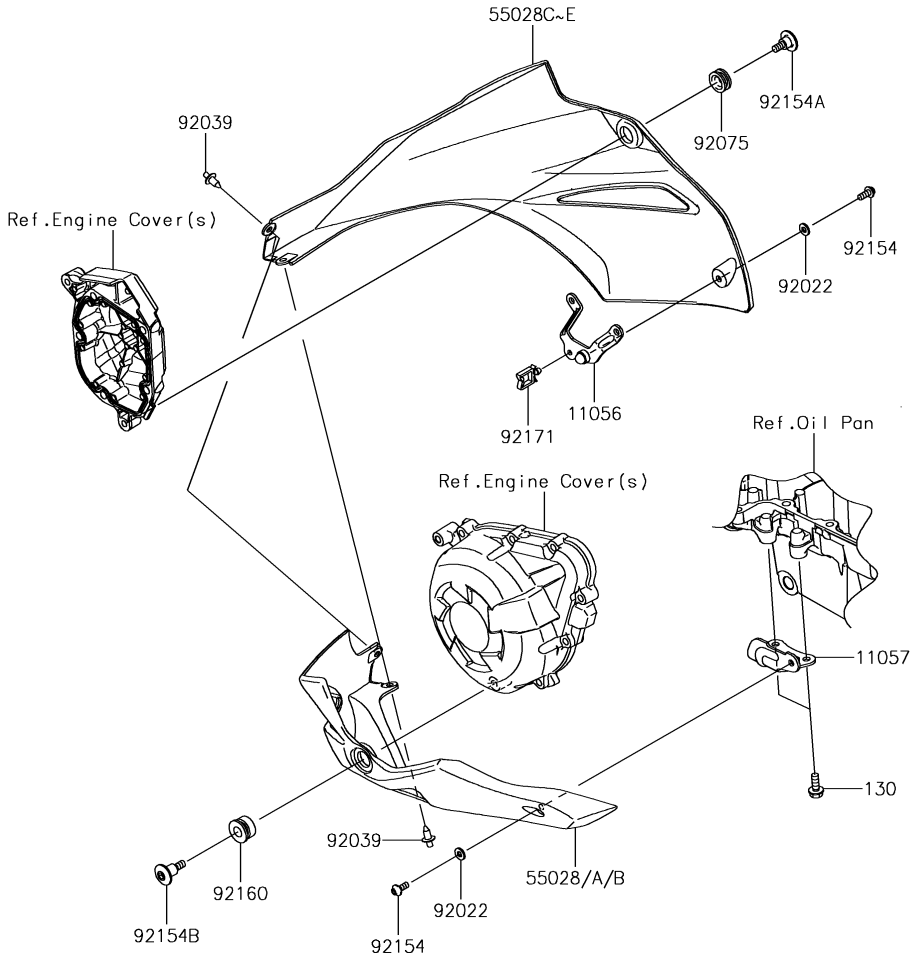

67. Cowling Lowers

Ref. No.	Part No.	Description	Spec Code	Quantity			
				'17	'18		
				HHF	HJF		
11056	11056-3926	BRACKET,LWR COWL.,RH		1	1		
11057	11057-0713	BRACKET,LWR COWL.,LH		1	1		
55028	55028-0494-36S	COWLING,LWR,LH,P.S.GRAY			1		
55028A	55028-0494-45W	COWLING,LWR,LH,M.G.GRAY		1	1		
55028B	55028-0494-739	COWLING,LWR,LH,M.F.S.BLACK		1			
55028C	55028-0495-36S	COWLING,LWR,RH,P.S.GRAY			1		
55028D	55028-0495-45W	COWLING,LWR,RH,M.G.GRAY		1	1		
55028E	55028-0495-739	COWLING,LWR,RH,M.F.S.BLACK		1			
92022	92022-1521	WASHER,NYLON,5.3X11.5X1.5		2	2		
92039	92039-0068	RIVET		2	2		
92075	92075-1634	DAMPER		1	1		
92154	92154-0917	BOLT,SOCKET,5X12		2	2		
92154A	92154-2316	BOLT,SOCKET,6X18		1	1		
92154B	92154-2317	BOLT,SOCKET,6X24		1	1		
92160	92160-1141	DAMPER		1	1		
92171	92171-0290	CLAMP		1	1		
130	130CC0616	BOLT-FLANGED,6X16		2	2		

68. Accessory(Shroud Slider)

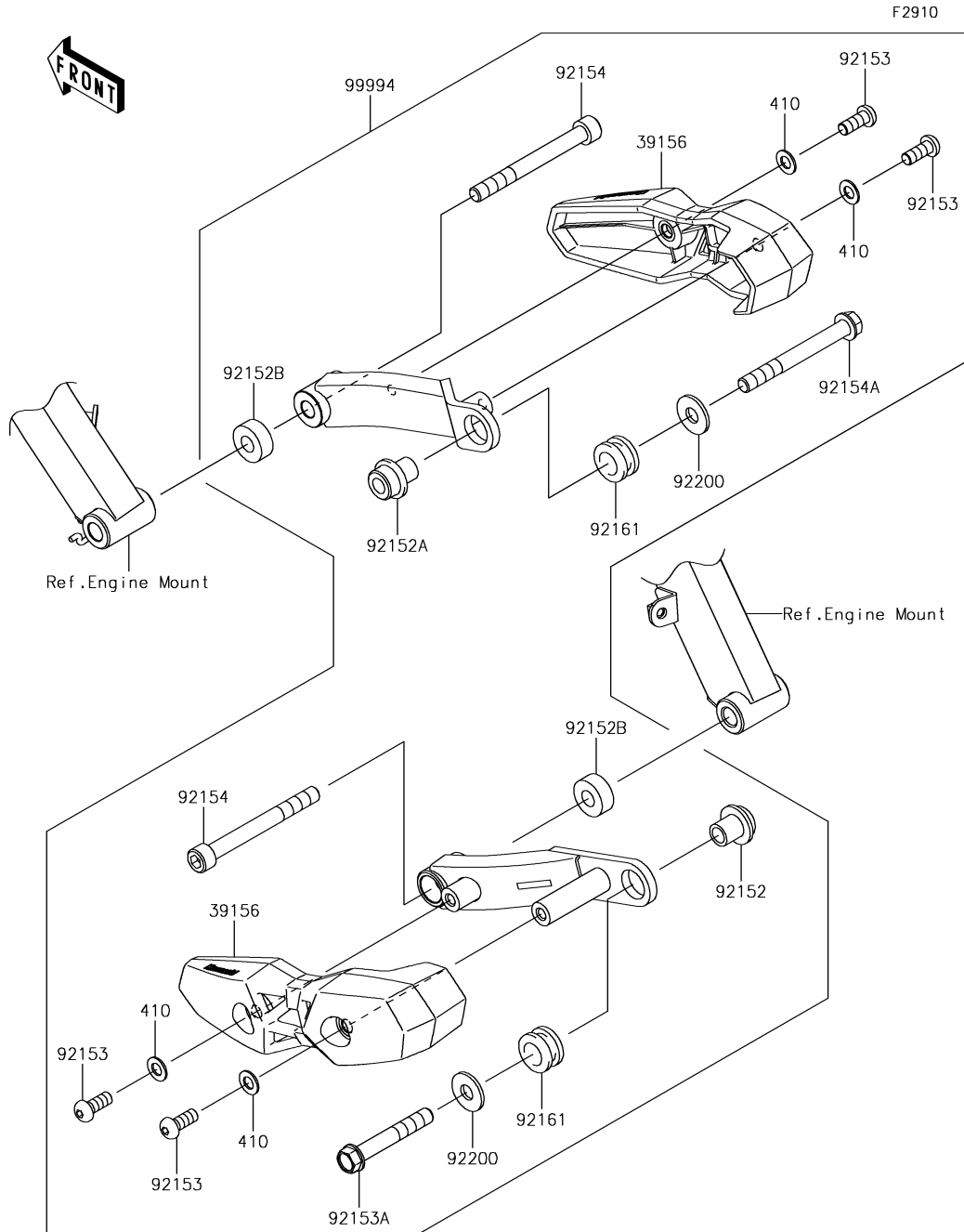

Ref. No.	Part No.	Description	Spec Code	Quantity			
				'17	'18		
				HHF	HJF		
39156	39156-1818	PAD,SLIDER		2	2		
92152	92152-1519	COLLAR,RR,LH		1	1		
92152A	92152-1520	COLLAR,RR,RH		1	1		
92152B	92152-1790	COLLAR		2	2		
92153	92153-0912	BOLT,SOCKET,8X20		4	4		
92153A	92153-1931	BOLT,FLANGED,10X65		1	1		
92154	92154-0447	BOLT,SOCKET,10X95		2	2		
92154A	92154-0448	BOLT,FLANGED,10X90		1	1		
92161	92161-1361	DAMPER,15.5X26X14.5		2	2		
92200	92200-0088	WASHER,10.5X26X2.3		2	2		
99994	99994-0400	KIT-ACCESSORY,SHROUD SLIDER		1	1		
410	410AB0800	WASHER-PLAIN-SMALL,8MM,BLACK		4	4		

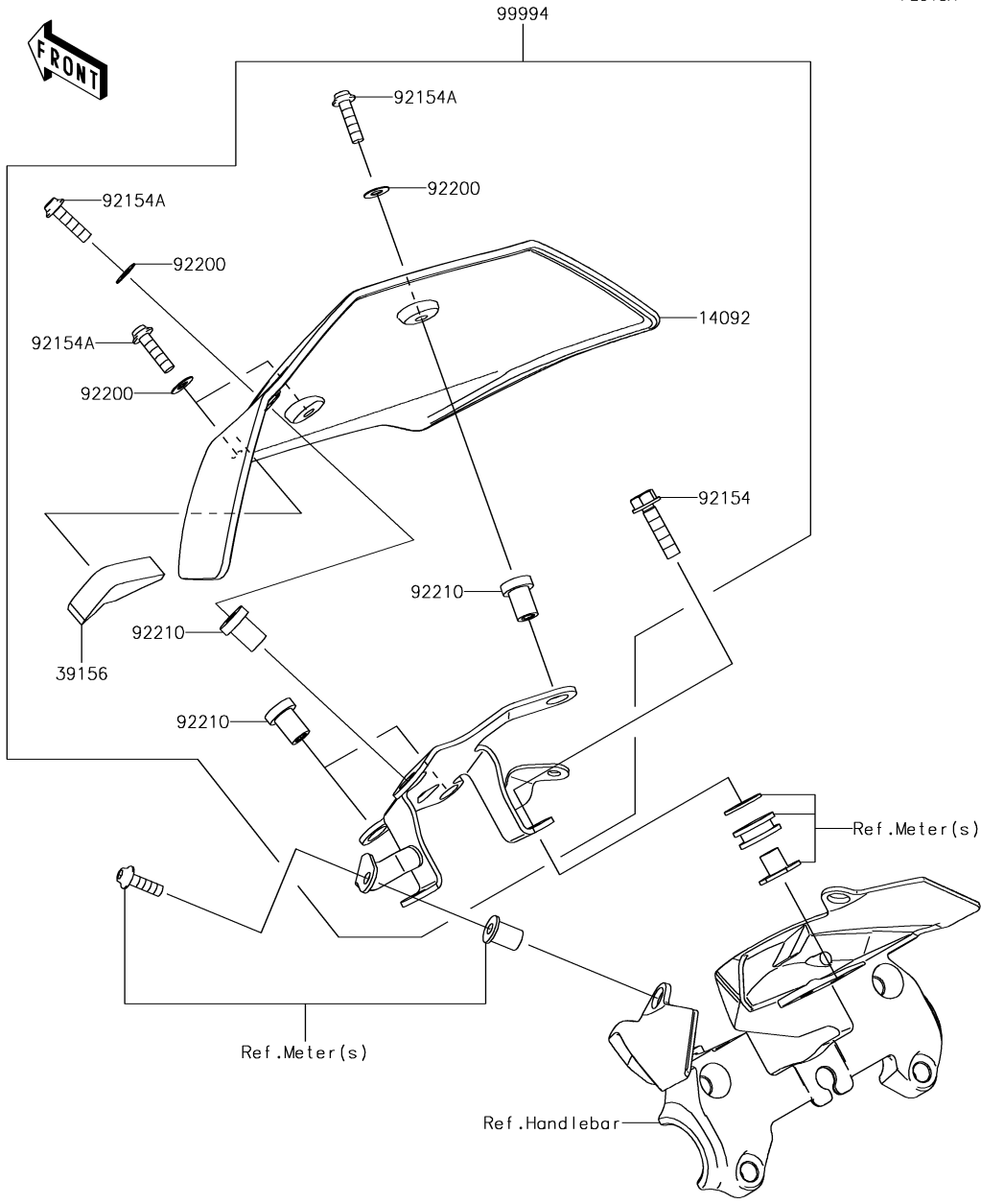

69. Accessory(Meter Cover)

Ref. No.	Part No.	Description	Spec Code	Quantity			
				'17	'18		
				HHF	HJF		
14092	14092-1134	COVER,METER		1	1		
39156	39156-1817	PAD		1	1		
92154	92154-0707	BOLT,FLANGED,6X25		2	2		
92154A	92154-0829	BOLT,SOCKET,5X20		4	4		
92200	92200-0006	WASHER,NYLONE,5.3X11.5X0.5		4	4		
92210	92210-0001	NUT,5MM		4	4		
99994	99994-0402	KIT-ACCESSORY,METER COVER		1	1		

F2910B

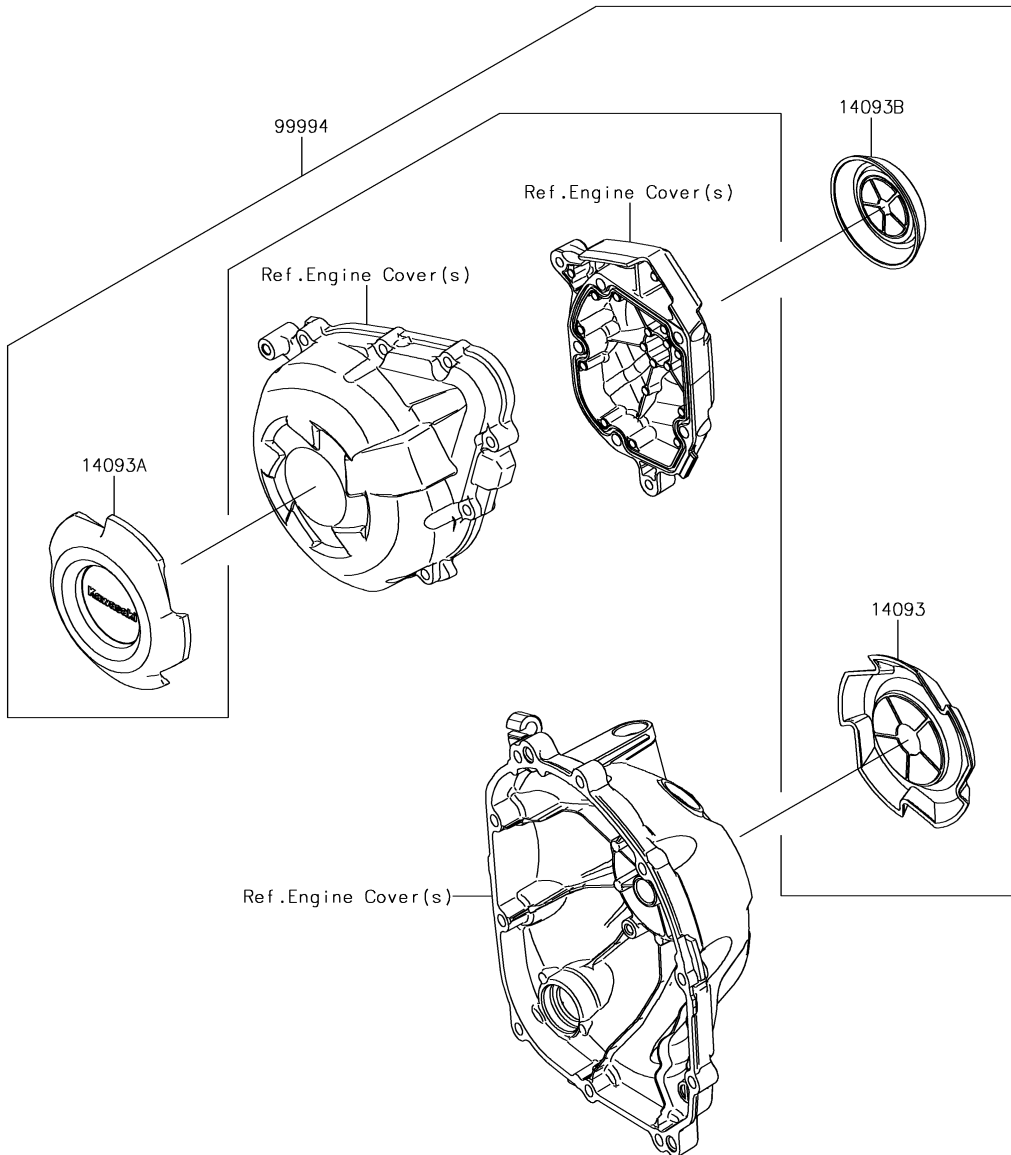

70. Accessory(Crankcase Ring)

Ref. No.	Part No.	Description	Spec Code	Quantity			
				'17	'18		
				HHF	HJF		
14093	14093-0571	COVER,CLUTCH		1	1		
14093A	14093-0573	COVER,ACG		1	1		
14093B	14093-0575	COVER,PULSER		1	1		
99994	99994-0929	KIT-ACCESSORY,CRANKCASE RING		1	1		

F2910C

71. Accessory(Axle Slider)

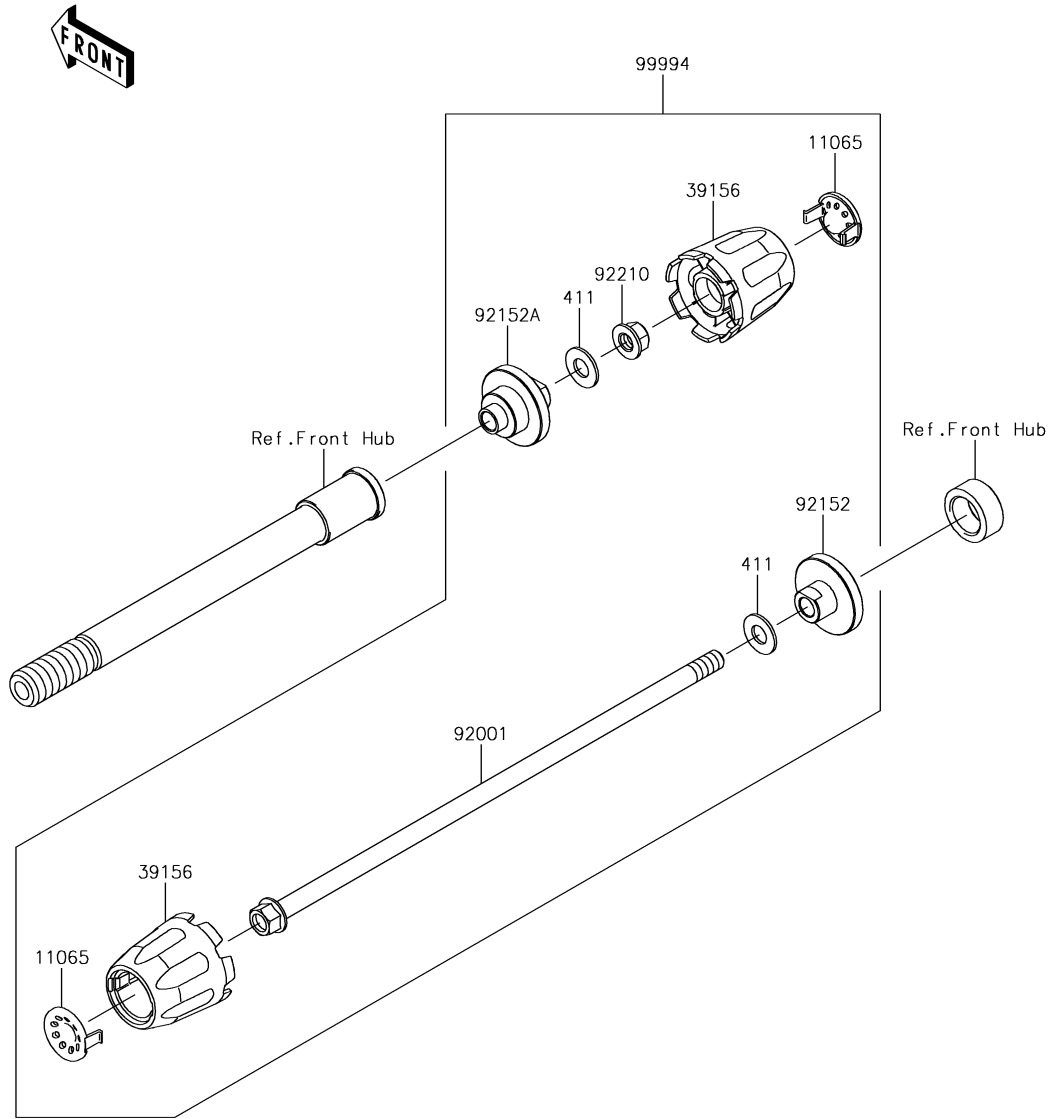

Ref. No.	Part No.	Description	Spec Code	Quantity			
				'17	'18		
				HHF	HJF		
11065	11065-0960-54N	CAP,B,SILVER		2	2		
39156	39156-2212	PAD,AXLE SLIDER		2	2		
92001	92001-1624	BOLT,FLANGED,10X320,BLACK		1	1		
92152	92152-2305	COLLAR,LH,L=25.5		1	1		
92152A	92152-2323	COLLAR,RH,L=36		1	1		
92210	92210-1139	NUT,LOCK,FLANGED,10MM		1	1		
99994	99994-0941	KIT,FRONT AXLE SLIDER		1	1		
411	411AA1000	WASHER-PLAIN,10MM		2	2		

F2920

Owner's Manual
(Local Procurement)

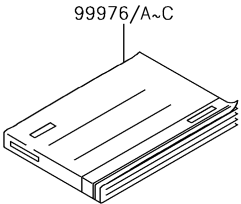

Ref.No.	Language
(99976/B)	English
	French
	German
(99976A/C)	Italian
	Spanish
	Dutch

Service Manual

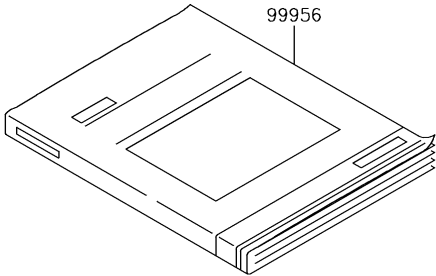

Ref.No.	Language
(99901)	Dutch
(99924)	English
(99953)	German
(99954)	French
(99955)	Italian
(99956)	Spanish

72. Manual

Ref. No.	Part No.	Description	Spec Code	Quantity			
				'17	'18		
				HHF	HJF		
99901	99901-0064-03	SERVICE MANUAL,DUTCH		1	1		
99924	99924-1518-03	SERVICE MANUAL,ENGLISH		1	1		
99953	99953-1104-03	SERVICE MANUAL,GERMAN		1	1		
99954	99954-1124-03	SERVICE MANUAL,FRENCH		1	1		
99955	99955-1091-03	SERVICE MANUAL,ITALIAN		1	1		
99956	99956-1079-03	SERVICE MANUAL,SPANISH		1	1		
99976	99976-0033	OWNER'S MANUAL,EN/FR/DE		1			
99976A	99976-0034	OWNER'S MANUAL,IT/ES/NL		1			
99976B	99976-0086	OWNER'S MANUAL,EN/FR/DE					1
99976C	99976-0087	OWNER'S MANUAL,IT/ES/NL					1

Part No.	Fig No.	Part No.	Fig No.	Part No.	Fig No.	Part No.	Fig No.	Part No.	Fig No.	Part No.	Fig No.
11004-0084	1	11065-0374	45	130CA0616	17	132BA0616	30	16085-0134	9	23026-0028	54
11005-0627	3	11065-0815	4	130CC0616	26	132BA0620	44	16085-0609	25	23037-0330	55
11008-0897	1	11065-0836	50	130CC0616	67	132BA0625	44	16097-0008	22	23037-0331	55
11009-1145	27	11065-0947-11G	47	13102-0047	10	132BA0625	58-1	16115-1053	16	23037-0342	55
11010-0857	4	11065-0948-11G	47	13107-0157	7	132BB0630	41	16126-0038	4	23037-0343	55
11012-1084	27	11065-0960-54N	71	13107-0214	22	132BC0660	22	16126-0705	21	23037-0356	56
11013-0712	4	12004-0747	6	13107-1376	7	14001-0670	14	16126-1140	37	23037-0357	56
11054-1904	58	12005-0768	6	13107-1377	25	14013-1051	14	16130-1058	22	23037-0358	56
11055-1785	44	12009-1091	6	13127-0073	11	14014-0036	14	16142-0064	22	23037-0359	56
11056-0124	20	12011-1053	6	13128-0054	11	14026-0135	16	16142-0746	22	23062-0788	66
11056-0161	58	12021-0016	2	13140-0061	12	14031-0610	16	16154-0057	22	23062-0789	53
11056-1084	58	12032-0009	6	13140-0062	12	14032-0631	16	16160-0796	22	23062-0790	53
11056-2434	57	12046-0564	7	13144-0070	11	14073-0722	4	16163-0902	18	23062-0801	58
11056-2479	17	12048-0080	7	13145-0048	12	14075-0028	27	16164-0009	21	23062-0816	30
11056-2480	21	12053-0161	7	13159-0008	44	14092-0001	54	18091-1108	5	23062-0819	57
11056-2507	58	12053-0162	7	13161-0592	13	14092-0016	30	18091-1120	5	23062-0977	53
11056-2510	66	12053-0163	7	13168-0115	9	14092-0032	16	186BB0618	57-1	25023-0094	50
11056-2511	66	120CA0516	53	13187-0031	10	14092-0109	25	21003-0172	23	25031-0726	50
11056-2512	66	120CA0525	20	13194-1096	25	14092-1098	27	21007-0141	45	26006-0001	25
11056-2513	66	120CB0510	25	13216-0020	22	14092-1128	48	21007-0166	43	26006-0001	57
11056-2514	66	120CC0525	48	13234-0038	9	14092-1129	48	21007-0579	24	26006-0020	57
11056-2515	66	13001-0114	3	13235-0008	47	14092-1130	58	21007-0646	23	26006-0055	57
11056-2522	53	13002-0004	3	13236-0068	13	14092-1133	50	21007-5078	58	26006-1080	25
11056-2531	57	13008-0572	3	13236-0729	42	14092-1134	69	21039-0004	25	26006-1080	57
11056-2686	53	13031-0710	8	13236-0743	40	14092-1135	30	21040-0003	25	26011-0275	57
11056-2761	66	13041-0040	9	13236-0788	13	14092-1156	46	21066-0756	23	26011-0822	57
11056-3839	48	13042-5001	46	13239-0577	12	14092-1157	46	21163-0761	25	26011-0839	57
11056-3887	44	13045-1057	4	13242-0139	13	14092-1164	50	21171-0033	24	26011-0951	25
11056-3926	67	13087-0583	10	13251-0726-II	8	14092-1166	57	21175-1213	20	26012-0709	57
11056-3933	66	13088-0568	10	13262-0753	11	14093-0089-17L	66	21176-0009	20	26031-2160	20
11056-3936	57	13089-0023	10	13262-1255	11	14093-0089-36S	66	21176-0026	20	26031-2162	57
11057-0290	23	13089-0024	10	13262-1256	11	14093-0089-60R	66	21176-0048	20	26031-2338	57
11057-0429	30	13089-1073	10	13262-1257	11	14093-0089-660	66	21176-0111	18	27002-0025	57
11057-0430	30	13089-1084	10	13262-1258	11	14093-0090-17L	66	21176-0132	20	27002-0029	57
11057-0713	67	13089-1115	10	13262-1259	11	14093-0090-36S	66	21176-0825	12	27002-1097	57
11057-1334	57	13095-0572	10	13262-1260	11	14093-0090-60R	66	21176-0836	45	27003-0096	57
11060-1103	5	130BA0512	24	13262-1270	11	14093-0090-660	66	21176-0841	42	27005-0601	58
11061-0029	43	130BA0518	30	13262-1271	11	14093-0543	16	21176-0845	12	27008-0601	58
11061-0107	22	130BA0608	41	13262-1272	11	14093-0562	2	21176-0846	12	27010-0112	58
11061-0204	45	130BA0610	57-1	13272-0698	14	14093-0571	70	21181-0010	58	27010-0749	58
11061-0402	3	130BA0612	21	13272-0699	14	14093-0573	70	220AB0614	51	27010-0762	42
11061-0403	16	130BA0612	41	13272-0859	16	14093-0575	70	224AB0408	55	27010-0770	25
11061-0404	16	130BA0612	58-1	13272-1413	10	16007-0034	6	224AB0408	56	27010-0854	46
11061-0405	4	130BA0614	30	13272-1719	42	16007-0711	10	225AB0412	44	27010-1313	14
11061-0406	4	130BA0616	30	13280-0248	46	16014-0002	18	23001-0043	53	27012-0171	48
11061-0424	4	130BA0625	54	13280-0772	46	16021-0025	18	23007-0205	55	27012-0764	48
11061-0726	5	130BB0616	57-1	13280-0814	25	16065-0067	1	23007-0206	55	27012-0776	66
11061-0914	2	130BB0630	4	132BA0610	44	16073-0053	25	23016-0570	53	27012-0779	30
11061-1213	2	130BB0670	48	132BA0610	57-1	16073-3707	18	23016-0605	54	27012-0843	30
11065-0328	2	130BB0814	66-1	132BA0612	22	16082-0773	41	23025-0332	54	27016-1115	58

Part No.	Fig No.	Part No.	Fig No.	Part No.	Fig No.	Part No.	Fig No.	Part No.	Fig No.	Part No.	Fig No.
27016-5388	58	36041-0032-660	52	39156-1812	35	43034-0110	45	46075-0068	46	51026-0010-40R	48
27048-5080	58	39007-0405-18R	32	39156-1817	69	43044-0074	45	46076-0125	46	51026-0010-45L	48
28012-1077	58	39060-0072	26	39156-1818	68	43048-0023	43	46091-0357	46	51044-0862	19
28012-1088	58	39062-0296	27	39156-1886	57	43048-0024	43	46091-0359	46	51049-0039	48
31064-0199	18	39062-0308	27	39156-1968	48	43049-0012	43	46092-0568	46	52005-1120	16
32033-1535	22	39062-0309	27	39156-1968	57	43049-0013	43	46102-0630	10	53003-0362-MA	49
32043-0583-18R	36	39062-0310	27	39156-2163	52	43049-1068	43	461DB0500	25	53003-0386-41C	49
32052-0155	30	39062-0313	27	39156-2212	71	43049-1097	45	480J1100	22	53003-0386-MA	49
32052-0744	48	39062-0727	27	39156-2234	57	43049-1107	43	480J1400	13	53004-0560	30
32085-0047	33	39062-0757	27	39178-0266	5	43056-0007	43	482EA0100	33	53044-0001	57
32097-0042	30	39062-0766	27	39192-0619	27	43056-0007	45	482EA5000	33	53044-0018	30
32099-0767	46	39062-1873	27	39192-0620	27	43056-1056	42	482J0200	13	53044-0033	58
32160-0694-18R	28	39068-0704	27	39193-0054	14	43057-003	43	49002-0009	1	53044-0561	58
32160-0695-18R	28	39110-0033	13	41009-0623	37	43057-003	45	49006-1054	45	53044-0577	66
32160-0696-18R	28	39111-0345	32	41009-0624	37	43057-1001	42	49006-1095	45	53044-1296	48
32160-0697	28	39156-0096	58	41068-0616	38	43078-0060	44	49006-1212	45	53066-0409-12Y	49
32190-0458-18R	29	39156-0563	48	41068-0622	39	43078-0566	27	49016-0609	26	53066-0550-41C	49
32190-0650-18R	29	39156-0617	58	41073-0613-18F	39	43078-0569	42	49016-0612	26	53066-0550-MA	49
32190-0651-18R	29	39156-0866	30	41073-0708-18F	38	43080-0141-DJ	45	49033-0012	18	54010-0597	51
33001-0671-18R	31	39156-1728	5	41073-0724-18F	38	43080-0143-DJ	43	49034-0049	17	54011-0619	51
33032-0044	31	39156-1729	5	41073-0725-18F	39	43080-0144-DJ	43	49040-0729	19	54012-0601	51
34024-0118-18R	36	39156-1730	5	41075-0007	37	43082-0147	43	49047-0023	12	54012-0602	51
34028-0092	33	39156-1731	5	41075-0008	37	43082-0167	45	49054-0004	27	55020-0782	58
34028-0093	33	39156-1733	30	41075-0009	37	43084-003	45	49056-0014	18	55020-0903	31
34028-0094	33	39156-1734	30	41080-0602-5C	43	43094-0008	46	49063-1055	22	55020-0907	5
34028-0095	33	39156-1736	66	41080-0632	45	43095-0510	44	49065-0026	22	55020-0908	5
35004-0310-45L	34	39156-1746	54	410AB0800	68	43095-0785	44	49078-0073	6	55020-0999	58
35004-0310-660	34	39156-1747	46	411AA1000	71	43095-0786	44	49085-1066	27	55020-1000	58
35004-0310-739	34	39156-1751	52	411AB1000	29	43095-0811	44	49091-0001	41	55028-0486-17L	65
35015-0036	35	39156-1754	58	42033-0028	39	43095-0981	41	49091-0001	44	55028-0486-36S	65
35015-0037	35	39156-1755	58	42036-0069	31	43095-0982	41	49106-0762	5	55028-0486-45L	65
35015-0040	35	39156-1774	21	42036-1153-KX	31	43095-0983	41	49118-0144	7	55028-0486-660	65
35015-0041	35	39156-1778	30	42036-1251	39	44008-0070-499	47	49118-0782	7	55028-0487-25V	65
35023-0378	35	39156-1784	48	42036-1265-KX	31	44013-0221-18R	47	49125-0575-17L	66	55028-0487-40R	65
35023-0379	35	39156-1786	35	42036-1342	32	44013-0222-18R	47	49125-0575-25V	66	55028-0487-45L	65
35023-0380	35	39156-1787	35	42041-0127	39	44023-0136-11G	47	49125-0575-40R	66	55028-0487-60R	65
35023-0424	35	39156-1788	35	43007-0016-18R	40	44023-0137-11G	47	49125-0575-60R	66	55028-0488-25V	65
35063-0657-18R	30	39156-1790	54	43010-1062	44	44026-0180	47	49125-0576-45L	66	55028-0488-45L	65
35063-0659-18R	30	39156-1791	54	43015-0596	44	44037-0141-18R	47	49125-0576-660	66	55028-0488-60R	65
35063-0660-18R	30	39156-1792	66	43015-0651	42	44039-0136-18R	47	49125-0577-17L	66	55028-0488-660	65
35063-0761	26	39156-1794	49	43020-0020	42	44065-0030	47	49125-0577-25V	66	55028-0489	65
35063-0920-18R	30	39156-1796	50	43020-1057	44	44065-0031	47	49125-0577-40R	66	55028-0490-25V	65
36014-0029	35	39156-1797	54	43020-1119	45	44065-0033	47	49125-0577-60R	66	55028-0490-45L	65
36041-0031-17L	52	39156-1799	53	43026-0009	44	44065-0047	47	49133-0017-45L	66	55028-0490-60R	65
36041-0031-36S	52	39156-1803	57	43026-0011	42	44071-1241-48T	47	49133-0017-660	66	55028-0490-660	65
36041-0031-60R	52	39156-1804	57	43027-0003	42	44071-1242-48T	47	51001-0791-17L	48	55028-0491	65
36041-0031-660	52	39156-1808	35	43027-1053	44	45014-0573-10	32	51001-0791-36S	48	55028-0492	66
36041-0032-17L	52	39156-1809	50	43028-0008	42	46003-0632	46	51001-0791-60R	48	55028-0493	66
36041-0032-36S	52	39156-1810	46	43028-1065	44	46012-0347-18R	46	51001-0791-660	48	55028-0494-36S	67
36041-0032-60R	52	39156-1811	28	43034-0057	42	46019-0020	46	51026-0010-25V	48	55028-0494-	67

Part No.	Fig No.	Part No.	Fig No.	Part No.	Fig No.	Part No.	Fig No.	Part No.	Fig No.	Part No.	Fig No.
55028-0494-739	67	56054-1573	58	670D1505	14	92025-1137	10	92043-1690	14	92055-1370	25
55028-0495-36S	61	56054-1914	61	670D1509	7	92026-0082	9	92043-1709	43	92055-1503	22
55028-0495-	67	56054-1914	62	670D2014	17	92026-022	10	92043-4009	2	92055-1536	1
55028-0495-739	67	56054-1914	63	670D2014	7	92026-1276	47	92045-0003	11	92055-1571	22
550AA2015	40	56054-1914	64	670E5075	19	92026-1497	10	92045-0017	31	92055-1622	18
550AA2015	44	56054-1975	58	671B2560	39	92027-1045	58	92045-0820	38	92055-3018	22
551A0408	22	56054-2170	62	92001-1342	27	92027-1651	23	92045-1045	12	92057-0202	7
551A0814	16	56054-2171	61	92001-1342	30	92028-1739	11	92045-1384	28	92057-0203	39
56001-0343-46V	46	56054-2171	63	92001-1624	71	92028-1915	11	92046-0008	31	92058-0027	39
56001-0344-46V	46	56054-2343	64	92002-1086	26	92033-0034	42	92046-0034	16	92062-0046	14
56007-0153	59	56069-1648	61	92002-1154	22	92033-0079	44	92046-0043	14	92065-097	17
56008-0570	59	56069-2527	62	92002-1323	42	92033-015	11	92046-1052	10	92066-0032	47
56030-0830	57	56071-0316	60	92002-1796	16	92033-026	11	92046-1219	11	92066-0071	28
56030-0857	57	56071-0694	60	92004-0028	39	92004-0028	47	92046-1263	10	92066-0079	17
56033-0861	60	56071-0765	60	92004-0050	1	92033-1041	31	92046-1266	9	92066-0832	1
56038-1054	60	56075-2474	62	92005-0721	21	92033-1043	39	92046-1273	32	92066-0836	14
56052-0869	64	56075-2475	62	92005-0753	21	92033-1054	3	92046-1303	11	92066-0919	56
56053-0935	60	56075-2476	62	92005-0842	27	92033-1156	39	92048-0016	11	92066-1012	14
56054-0607	61	56075-2477	62	92005-1238	14	92033-1186	44	92048-0018	25	92066-1077	46
56054-0607	62	56075-2480	61	92005-1273	1	92033-1249	11	92049-0022	28	92066-1110	14
56054-0607	63	56075-2481	61	92009-1391	50	92037-010	48	92049-0125	47	92069-0090	55
56054-0607	64	56075-2481	63	92009-1984	20	92037-147	21	92049-0723	39	92069-1016	54
56054-0608	61	56075-2482	61	92009-1984	35	92037-147	27	92049-0742	28	92070-0014	24
56054-0608	62	56075-2483	61	92015-1180	29	92037-1505	27	92049-0798	22	92071-0024	25
56054-0608	63	56075-2483	63	92015-1189	32	92037-1712	21	92049-1057	38	92071-0722	5
56054-0608	64	56075-4008	63	92015-1233	23	92037-1712	4	92049-1223	32	92072-3768	58
56054-0672	61	56075-4009	63	92015-1311	8	92037-1903	58	92049-1287	39	92075-051	66
56054-0672	63	56075-4010	63	92015-1367	21	92037-2014	57	92049-1314	31	92075-1011	66
56054-1245	61	56075-4011	64	92015-1476	25	92037-2116	21	92049-1349	6	92075-1123	26
56054-1245	62	56075-4012	64	92015-1487	26	92038-1060	23	92049-1352	31	92075-1564	58
56054-1245	63	56075-4013	64	92015-1528	42	92039-0060	35	92049-1474	14	92075-161	53
56054-1245	64	56075-4014	64	92015-1555	10	92039-0068	66	92049-1475	16	92075-1634	50
56054-1246	61	56075-4015	64	92015-1700	35	92039-0068	67	92049-1520	14	92075-1634	67
56054-1246	62	57001-1752	61	92015-1757	30	92039-0705	34	92049-2204	9	92075-1912	20
56054-1246	63	57001-1752	62	92015-1757	50	92039-0730	26	92055-0016	20	92075-1927	49
56054-1246	64	57001-1752	63	92015-1757	53	92039-1251	60	92055-0064	18	92075-277	23
56054-1280	61	57001-1752	64	92015-1757	58	92042-007	1	92055-0114	27	92081-1708	13
56054-1280	62	59026-0043	24	92015-1757	65	92042-007	16	92055-0136	25	92081-1737	44
56054-1280	63	59051-0762	25	92015-1757	66	92042-030	22	92055-0137	42	92092-1081	5
56054-1280	64	59071-0014	18	92022-077	22	92043-0904	44	92055-0142	47	92092-1087	5
56054-1281	61	59071-3752	18	92022-1116	10	92043-1037	14	92055-0174	47	92093-0035	47
56054-1281	62	59256-0555	22	92022-112	11	92043-1262	22	92055-0199	16	92093-0604	48
56054-1281	63	59502-0612	26	92022-1369	50	92043-1263	16	92055-0739	27	92093-1030	48
56054-1281	64	600A0500	11	92022-1405	66	92043-1263	17	92055-0741	42	92104-0004	59
56054-1356	61	600A0800	33	92022-1521	67	92043-1263	22	92055-0741	44	92104-1064	59
56054-1356	62	601B6205UU	39	92022-1618	39	92043-1264	1	92055-0778	30	92104-2068	59
56054-1356	63	601B6304UU	39	92022-1628	13	92043-1264	14	92055-0785	2	92106-1001	59
56054-1356	64	610A0406	12	92022-1868	10	92043-1489	45	92055-0831	27	92107-1051	59
56054-1370	62	610A0410	9	92022-289	5	92043-1594	33	92055-086	7	92110-1104	59
56054-1572	58	670B2020	16	92022-326	40	92043-1595	33	92055-1276	25	92110-1108	59

Part No.	Fig No.	Part No.	Fig No.	Part No.	Fig No.	Part No.	Fig No.	Part No.	Fig No.	Part No.	Fig No.
92110-1140	59	92151-1654	57	92153-0549	24	92154-0413	9	92154-2483	46	92171-0179	27
92110-1152	59	92151-1764	27	92153-0656	1	92154-0447	68	92154-2596	46	92171-0290	67
92110-1153	59	92151-1829	7	92153-0702	5	92154-0448	68	92154-2624	28	92171-0729	1
92110-3703	59	92151-1873	16	92153-0802	29	92154-0477	12	92154-2638	1	92171-0782	41
92126-004	59	92151-1899	31	92153-0816	35	92154-0477	23	92154-2639	15	92171-0907	31
92127-003	59	92151-1930	25	92153-0854	47	92154-0482	16	92154-2640	15	92171-0921	45
92139-0023	13	92151-1930	7	92153-0868	42	92154-0484	14	92154-2644	46	92171-1283	20
92139-0032	8	92151-1930	9	92153-0906	58	92154-0502	46	92154-2650	23	92171-1722	57
92139-0033	8	92151-1997	27	92153-0912	68	92154-0551	57	92154-2652	16	92171-1819	42
92139-0034	8	92152-0087	38	92153-1045	15	92154-0707	50	92160-1141	67	92171-1819	45
92139-0067	10	92152-0118	39	92153-1442	28	92154-0707	69	92160-1162	4	92172-0064	18
92139-0122	8	92152-0134	20	92153-1505	13	92154-0745	35	92160-1167	48	92172-0238	57
92139-0123	8	92152-0154	31	92153-1526	48	92154-0827	29	92160-1190	54	92172-0262	35
92139-0124	8	92152-0286	5	92153-1528	23	92154-0829	69	92160-1496	32	92172-0262	53
92139-0217	8	92152-0286	57	92153-1580	41	92154-0907	5	92160-1613	48	92172-0262	65
92139-0218	8	92152-0547	4	92153-1624	30	92154-0917	48	92160-1613	50	92172-0262	66-1
92139-0219	8	92152-0666	54	92153-1637	15	92154-0917	52	92160-1613	52	92172-0265	16
92139-0278	45	92152-0667	26	92153-1779	2	92154-0917	67	92160-1613	53	92172-0265	53
92139-0280	11	92152-0679	43	92153-1837	5	92154-1116	10	92160-1613	65	92172-0265	65
92139-0281	11	92152-0757	47	92153-1850	25	92154-1225	25	92160-1613	66-1	92172-0319	42
92143-1057	27	92152-0812	11	92153-1853	42	92154-1236	46	92161-0054	53	92172-0334	25
92143-1379	46	92152-0853	29	92153-1866	25	92154-1271	42	92161-0070	22	92172-0343	54
92143-1595	13	92152-0876	39	92153-1890	43	92154-1292	46	92161-0117	58-1	92172-0477	53
92144-1467	46	92152-0892	39	92153-1930	5	92154-1421	48	92161-0118	58-1	92172-0481	54
92144-1523	13	92152-1074	58	92153-1931	68	92154-1530	46	92161-0163	54	92172-0483	4
92144-1831	45	92152-1167	7	92153-1938	33	92154-1701	50	92161-0266	52	92172-0855	42
92145-0562	36	92152-1182	48	92153-1948	23	92154-1712	41	92161-0306	5	92172-1117	55
92145-0580	43	92152-1234	31	92153-1948	48	92154-1712	44	92161-0308	5	92172-1138	46
92145-0603	33	92152-1383	13	92153-1948	66-1	92154-1838	13	92161-0342	39	92172-1185	46
92145-0760	45	92152-1519	68	92153-1956	48	92154-1848	19	92161-0356	20	92173-0037	5
92145-0761	58	92152-1520	68	92154-0205	1	92154-1852	29	92161-0673	18	92173-0088	41
92145-1122	13	92152-1739	38	92154-0209	30	92154-1858	58	92161-0776	54	92173-0115	4
92145-1319	33	92152-1740	27	92154-0209	35	92154-1865	43	92161-0801	14	92173-0126	20
92145-1630	10	92152-1782	30	92154-0209	53	92154-1865	45	92161-0856	23	92173-0127	21
92145-1753	40	92152-1790	68	92154-0209	58	92154-1898	58-1	92161-0856	5	92173-0127	27
92145-1770	10	92152-1828	36	92154-0209	65	92154-1942	7	92161-1055	9	92173-0127	44
92150-1186	26	92152-1863	48	92154-0209	66-1	92154-1963	36	92161-1300	13	92173-0170	44
92150-1216	8	92152-1880	53	92154-0210	66-1	92154-1976	42	92161-1330	48	92173-0736	21
92150-1251	15	92152-1888	47	92154-0211	66-1	92154-1976	45	92161-1361	68	92173-0799	41
92150-1339	30	92152-1960	45	92154-0262	32	92154-2090	13	92161-1561	53	92173-0861	21
92150-1483	15	92152-2075	50	92154-0263	32	92154-2096	12	92161-1584	30	92173-0861	57
92150-1794	15	92152-2279	39	92154-0264	32	92154-2309	29	92161-1584	48	92173-0868	44
92151-1135	16	92152-2305	71	92154-0267	29	92154-2310	29	92161-1608	49	92173-0868	51
92151-1225	17	92152-2323	71	92154-0293	40	92154-2311	29	92161-1673	41	92173-0868	57
92151-1289	45	92152-2331	48	92154-0299	14	92154-2316	67	92161-1947	30	92173-0970	57
92151-1539	15	92153-0381	14	92154-0351	2	92154-2317	67	92170-1060	4	92173-1099	45
92151-1605	48	92153-0393	44	92154-0372	15	92154-2318	46	92170-1091	44	92173-1112	42
92151-1654	34	92153-0406	1	92154-0379	28	92154-2324	31	92170-1493	27	92173-1144	45
92151-1654	45	92153-0446	13	92154-0385	44	92154-2327	40	92170-1695	21	92173-1153	34
92151-1654	53	92153-0488	29	92154-0403	27	92154-2330	36	92170-1925	57	92173-1154	34

Accessory(Axle Slider)	71	Gear Change Mechanism	13
Accessory(Crankcase Ring)	70	Generator	23
Accessory(Meter Cover)	69	Handlebar	46
Accessory(Shroud Slider)	68	Headlight(s)	53
Air Cleaner	4	Ignition Switch	58/58-1
Balancer	9	Ignition System	24
Brake Pedal	40	Labels	60
Brake Piping	41	Manual	72
Cables	51	Meter(s)	50
Camshaft(s)/Tensioner	7	Muffler(s)	5
Chassis Electrical Equipment	57/57-1	Oil Pan	17
Clutch	10	Oil Pump	22
Cowling Lowers	67	Owner's Tools	59
Cowling(Center)	66/66-1	Radiator	26
Cowling(Upper)	65	Rear Brake	45
Crankcase	14	Rear Fender(s)	35
Crankcase Bolt Pattern	15	Rear Hub	39
Crankshaft	8	Rear Master Cylinder	44
Cylinder Head	1	Seat	49
Cylinder Head Cover	2	Side Covers	52
Cylinder/Piston(s)	3	Stand(s)	36
Decals(Black)(HHF)	62	Starter Motor	25
Decals(Gray)(HJF)	64	Suspension/Shock Absorber	32
Decals(Green)(HJF)	63	Swingarm	31
Decals(Orange)(HHF)	61	Taillight(s)	54
Engine Cover(s)	16	Throttle	18
Engine Mount	29	Tires	37
Footrests	33	Transmission	11
Frame	28	Turn Signals(HHF)	55
Frame Fittings	30	Turn Signals(HJF)	56
Front Brake	43	Valve(s)	6
Front Fender(s)	34	Water Pipe	27
Front Fork	47		
Front Hub	38		
Front Master Cylinder	42		
Fuel Evaporative System	21		
Fuel Injection	20		
Fuel Pump	19		
Fuel Tank	48		
Gear Change Drum/Shift Fork(s)	12		

Kawasaki Heavy Industries, Ltd.
Motorcycle & Engine Company

Part No. 99912-0093-02

©2017, Kawasaki Heavy Industries, LTD

'17-'18 ZR1000 HHF/HJF(EU)

(Z1000)